



POLITÉCNICA

"Ingeniamos el futuro"

CAMPUS
DE EXCELENCIA
INTERNACIONAL

innovatech
UPM INNOVATIVE RESEARCH
UNIVERSIDAD POLITÉCNICA DE MADRID

Portfolio of technologies

UNIVERSIDAD POLITÉCNICA DE MADRID

(Technical University of Madrid - UPM)

A/W 2014/15

C A : T
CENTRO DE APOYO A LA
INNOVACIÓN TECNOLÓGICA

Centre for Support of Technological Innovation - UPM



POLITÉCNICA

"Ingeniamos el futuro"

CAMPUS
DE EXCELENCIA
INTERNACIONAL

innovatech
UPM INNOVATIVE RESEARCH
UNIVERSIDAD **POLITÉCNICA** DE MADRID

Portfolio of technologies

UNIVERSIDAD POLITÉCNICA DE MADRID

(Technical University of Madrid - UPM)

AW 2014/15



CENTRO DE APOYO A LA
INNOVACIÓN TECNOLÓGICA

Centre for Support of Technological Innovation - UPM

Delivery date: September, 2014

Images:

Page 5/ Wheat (or barley) seed head, Michigan © Martin LaBar Link: <http://bit.ly/1qX4FNx> CC BY 2.0

Page 17/ 91957046 © mattwalker69 Link: <http://bit.ly/1IFSdFJ> CC BY 2.0

Page 41/ Neural connections © Daniel Kulinski Link: <http://bit.ly/1tWB8bN> CC BY 2.0

Page 85/ Nanoscience High-Performance Computing Facility (Carbon) (3) © Argonne National Laboratory Link: <http://bit.ly/1JqfJt> CC BY 2.0

Page 131/ A Shooting Star in Space (NASA, International Space Station, 08/13/11) © NASA's Marshall Space Flight Center Link: <http://bit.ly/1lw590z> CC BY 2.0

Page 155/ Construction © Marja van Bochove Link: <http://bit.ly/1qfpJCN> CC BY 2.0

Reproduction is authorised provided the source is acknowledged

The Universidad Politécnica de Madrid (UPM) is the largest technical university in Spain and the leading Spanish university with regard to the participation in European R&D projects, patents filed and the creation of spin-off companies, for instance.

The Centre of Support for Technology Innovation (*CAIT – its initials in Spanish*) and specifically **innovatech** program is the UPM unit in charge of promoting the commercialization of R&D results, while serving as a stimulus to the innovation process in the business eco-system close to the University.

As part of its activity, **innovatech** program periodically updates the portfolio of UPM technologies, which includes a set of innovative technology solutions, public, developed by the UPM research teams and classified by industrial sectors. In this version (September 2014), 70 commercial sheets have been published, including information such as the technology solution description, development stage, IPR issues, competitive advantages and application sectors.

UPM is interested in reaching commercial, technical or collaboration agreements with companies and research institutions.

If you are interested or need more information about specific UPM technologies, please contact **innovatech**, the UPM Technologies Commercialization Program:

w: upm.es/innovatech
e: innovacion.tecnologica@upm.es

Agro-food & Biotechnology

[Link](#)

Energy & Environment

[Link](#)

Health

[Link](#)

IT, Internet & Mobile

[Link](#)

Transport, Security & Space

[Link](#)

Construction & Infrastructure

[Link](#)



Agro-food & Biotechnology

Agro-food & Biotechnology

In this area, it is included technologies developed in the field of food production (such as agricultural, animal production...) and biotechnology, including here any technological application based in biological system, living organisms... to create or modify a product or process.

Mycetum

Advanced bioproduction generation

[Link](#)

eMIP

New method for manufacturing biochips based on MIPs at nanoscale level

[Link](#)

Living Roof

Urban gardens at roofs and terraces

[Link](#)

Check Agro-food & Biotechnology UPM technologies marketplace

[Website](#)

MYCETUM. Advanced bioproduction generation

Biotechnological solution for large-scale production of mycelium, a natural key component in pharmaceutical, biomedical and agricultural industries

The mycelium natural product is a key component in many industrial applications of high economic value (pharmacological active principles, biomedical and biomaterials, agriculture or mycology and forest restoration). Obtaining one of their products (chitosan), with applications in agriculture and biomedical industry, is growing annually by 13%, an annual output of 2.000 tons and a global market estimated at 1,000 M \$.

A research team from the EUIT Agrícola at the Technical University of Madrid has developed a patented and internationally protected solution for mycelium production scale in a controlled manner and with a simplified process industrially from the multiplication of fungi in vitro culture. Mycetum business opportunity is checked as multi-application solution for a remarkable number of target markets, including the pharmaceutical one, world leader in R & D investment and technology.

Technology solution supported by the Technical University of Madrid

Technology solution

This technological solution proposes an innovative method for obtaining global scale fungal mycelium in pure culture. The process develops inoculating the mycelium, for purification and then finally transfer for large-scale generation. This procedure can be implemented in industrial bioreactors for a rapid and controlled production.

The mycelium, a component of the fruit of the fungus, is a key component for the development of many applications of high economic value: extraction of active principles of pharmacological interest, obtaining chitosan (medicine, cosmetics, water treatment); obtaining principles food; biometariales generation and forest regeneration, among other applications.

"Patented technological process for obtaining a large-scale natural product from fungi (mycelium) for several high value industrial applications"



Areas of application

- **Health:** active ingredients used in pharma industry; biomedicine.
- **Biotechnology:** forestry practice and health.
- **Agri-food:** planting edible fungi.
- **Environment:** environmental regeneration.

Market demands

- Complex and expensive procedures to produce mycelium before obtaining pharmacological active ingredients.
- Soil erosion in mycological areas and lack of guarantee of origin of the fungus species.
- Production recovery in mycological depleted areas: need for a more sustainable development of rural areas.
- Improved plant production of edible mushrooms, especially those of great commercial value, such as truffles.
- The global truffle demand (1,000 tons in 2010) is still far from the current production capacity, highly dependent on environmental factors. Even in 2020, this demand would not be covered even 25%.

“Mycetum large-scale controlled production of mycelium improves key active ingredients generation for pharma industry”



Market potential

- Global pharmaceutical companies top rankings based on R&D investments (R&D expense at 17% of income), driven by Roche, Pfizer and Novartis [Global Innovation 1000, Booz & Co].
- Chitosan production market and derivatives (agricultural application or water purification component) has grown on average in recent years about 13%, with annual output of 2,000 tons. USA and Japan are the largest producers and consumers.
- USA companies producing chitin and chitosan generate a market equivalent to 335 M\$ per year, with an estimated global value higher than 1,000 M \$.
- World truffle plantation area grows at an annual rate of 9%, for an estimated production in 2020 of 270 tons [Micología Forestal Aplicada].

Competitive advantages

- Simplicity in the production process capable of meeting several demands according to different business priorities.
- Production capacity of large amounts of mycelia in a fast and controlled manner: reducing production costs and boosting scalability.
- Multi-application solution with high added value:
 - pharmacological: generation of active ingredients;
 - biomedicine, agriculture (seeds, fertilizers...), water treatment: obtaining the chitosan component and derivatives;
 - biomaterials (fillers, degradation of materials, packaging ...);
 - customized inoculated planting and 'designation of origin'.
- 100% in vitro production, as a non-polluting process, no environmental impact without associated degradation of the natural environment.

References

- Top worldwide research team in technological terms related to plant biotechnology and plant production.
- Mycetum spin-off creation for the marketing and business development.

IPR

- Patent granted in Spain ES2332031
- Patent granted in Mexico MX/a/2011/012647
- Patent applied in Chile 003013
- European patent applied via EPO EP10782999.6

Development stage

- Concept
- R&D
- Lab Prototype
- Industrial Prototype
- Production

Mycetum contact

Consuelo Jiménez Aguilar, Francisco González Torres, M^a Cruz Usano Martínez, César González García

EUIT Agrícola – UPM
e: consuelo.jimenez.aguilar@upm.es

UPM contact

Innovation, Commercialization and Entrepreneurship Area
Centre of Support for Technological Innovation – UPM
e: innovacion.tecnologica@upm.es

eMIP. New method for manufacturing biochips based on MIPs at nanoscale level

Design and synthesis of MIPs as patterned thin films with micro and nanoscale motifs by conventional techniques of micro and nanofabrication

The Technical University of Madrid and The Complutense University of Madrid have developed eMIP, a non-contact technique that allows the fabrication of nanoscale molecular imprinting polymers or MIPs. This method enables the design of "arrays" (matrices) of MIPs for the simultaneous detection of multiple (bio) chemical substances. Their nanometer size provides greater sensitivity so that smaller volumes of samples (analytes) and operating power are required. Moreover, as a non-contact technique avoid contaminating the MIP material as in other MIPs structuring techniques, such as printing molds. From the social point of view, the use of biochips and smart bio-tags manufactured by this method will allow that stringent storage conditions will not be required, making this innovation accessible to the less developed and less purchasing power societies.

Technology solution supported by the Technical University of Madrid

Technology solution

Non-contact technique for manufacturing MIPs nanostructures, through a direct write system, solving the technical problem of contamination of the polymeric material which results from the use of other techniques ("nanoimprinting").

Unlike other techniques which use electromagnetic radiation, the proposed solution is based on the irradiation of the surrounding material of the nano-patterning allowing the nano pattern unirradiated (and thus not damaged) acting as MIP.

Their nanometer size allows its use in the analysis of reduced sample volumes, thus saving. It is also possible the simultaneous detection of multiple analytes using "arrays" (MIPs matrices).

The technique allows synthesizing nanostructured MIPs for specific applications considering both the dimensions of the material and the capacity to identify a specific chemical compound. This solves the lack of biological substances sensitive to compounds of interest.

Areas of application

- ICTs applied to the detection and monitoring of chemicals
- Biotechnology: detection of biochemical compounds
- Agro Food Industry: labeled and food safety

"This synthesis method enables the design of "arrays" (matrices) of MIPs for the simultaneous detection of multiple bio chemical substances"

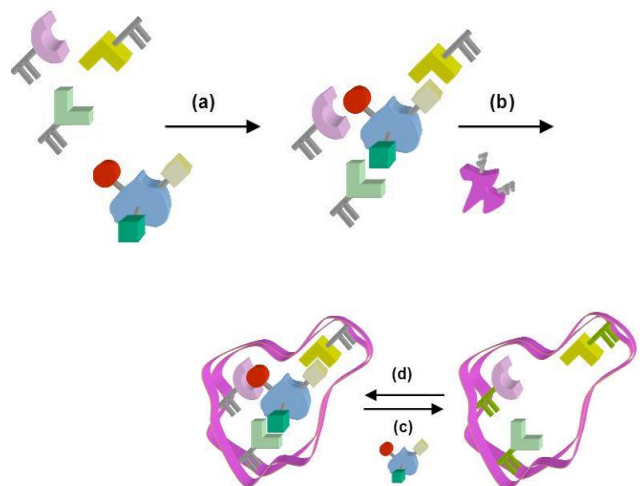

Market demands

Food sector

▪ Food Safety

The food safety legislation is becoming stricter therefore analytical methods are needed that allow detection of contaminants even at very low concentration levels.

Security

▪ Trademark Counterfeiting

The Anti-counterfeiting International Trademark Association estimates that the counterfeiting accounts for between 5 - 7% of world trade. The smart label is positioned as a solution to this problem.

▪ Detection of prohibited substances and / or toxic

Globalization implies a movement of goods on a large scale between countries with sometimes different regulations regarding toxic substances. Detection of these substances is therefore essential and not always feasible due to the lack of biological substances sensible to such substances.

“eMIP offers a double defense system against fraudulent attempts to copy tags thanks to the specificity of nanofabrication techniques and the chemical selectivity of the material”

Market potential

- Molecular imprinting technique is a rapidly growing field with a wide range of applications, especially in the area of development of sensors, where the technique leads to improved sensitivity, reliability, stability and reproducibility in detection equipment.
- The specific properties of MIPs, have made them a very interesting tool for various application areas, including separation and purification sciences, sensors and biosensors, catalysis and drug delivery.
- The nanostructuring of MIPs allows improving its performance as a sensor due to the increase of the area of interaction with the surrounding medium. Moreover, makes any attempt to illicit reproduction (fake) really difficult because specialized manufacturing equipment is required.

Competitive advantages

- Double security system based on the specificity of the method of manufacture of nanoscale patterns and the chemical selectivity of MIP material. This method for generating labels or codes makes really difficult any attempt to fake.
- It is possible to synthesize nanostructured MIPs for specific applications considering both the dimensions of the material and the capacity to identify a specific chemical compound. This solves the lack of biological substances sensitive to compounds of interest.
- Non-contact technique, avoiding the contamination of MIPs. This is a fundamental advantage over nano-printing techniques.

References

- Interuniversity multidisciplinary team specialized in nanotechnology, nanophotonics and functional nanomaterials, and MIPs and optical biosensors.

IPR

- Patent applied in Spain P201330947

Development stage

- Concept
- R & D
- Lab Prototype
- Industrial Prototype
- Production

eMIP contact

Carlos Angulo Barrios
Institute of Optoelectronics Systems and
Microtechnology (ISOM-UPM)
e: carlos.angulo.barrios@upm.es
w: <http://www.isom.upm.es>

UPM contact

Innovation, Commercialization and
Entrepreneurship Area
Centre of Support for Technological Innovation
– UPM
e: innovacion.tecnologica@upm.es

Living Roof. Urban gardens at roofs and terraces

A new and innovative cropping system of horticultural and ornamental species on roofs or terraces of buildings, with CO₂ capture and night lighting by O-LEDs

Researchers from the Technical University of Madrid and the University of Valladolid, have designed a system which lets urban crops to grow on roofs and terraces of buildings, 100% sustainable. Those urban orchards contribute to mitigate the CO₂ which pollutes the environment of big cities. Moreover, during the winter, they could take advantage of the CO₂ of flue gas heating boilers. These kinds of orchards have already been installed at the Agricultural Engineering School of the Technical University of Madrid.

Technology solution supported by the Technical University of Madrid

Technology solution

The urban orchards will be covered by a greenhouse in order to avoid that contaminant particles (heavy metals) which come from urban contamination are deposited over the crops. Rainwater will be harvested and nutrients will be circulated.

During the winter, the CO₂ of flue gas heating boilers is used in order to carry out the carbonic fertilization. During the rest of the year, porous materials are used to capture the CO₂.

Areas of application

- **Environment & Health:** CO₂ reduction in cities which is translated in fewer allergies, less cardiovascular problems, decrease of breathe diseases, etc.
- **Food production:** ecological vegetables and fruits can be produced with no risk as they will be under a greenhouse.

"Urban orchards are specially indicated to absorb the CO₂ produced in the heating boilers of the buildings, during the gasoil combustion, natural gas or biomass in the winter time".



Market demands

Environment

- Currently the number of people living in cities is higher than the rural habitants.
- Around 90% of the EU population which live in cities are exposed to atmospheric contaminants which are considered as nocuous by the World Health Organization [European Environment Agency, 2013].
- In Spain, approximately 50% of population is exposed to higher levels of ozone and tropospheric nitrogen particles [European Environment Agency, 2013].

Health

- A bad quality of the air produces high risks for human health and can cause or contribute to the development of illness such as cardiovascular and breath diseases or lung cancer.
- Air contamination has a big economic impact reducing life expectancy, increasing healthcare costs and reducing productivity.

Food production

- Growing vegetables and fruits in the cities means less contamination and the minimization of the economic waste during transport.



"In order to achieve a healthy urban environment will be enough to landscape 10-20% of all roofs of the city"

Market potential

- Costs due to the contamination in EU are estimated from 330 to 940 billion € per year (absence of work, less productivity, health waste...). There were around 400 000 premature deaths in 2010 [European Union].
- 1m2 vegetation cover makes the amount of oxygen required by a person in the whole year. It captures from the environment 50 grams of CO2 per day; it isolates thermally the building around 5°C; it reduces the acoustic contamination in 10 db; it produces fruits and vegetables in more quantity, quality and precocity; it does not consume electrical energy [Darlington, 2001].

Competitive advantages

- The greenhouse will avoid the deposition of contaminant particles (heavy metals) from urban contamination.
- It will harvest the rainwater.
- Uptake and utilization, during the winter, of flue gas heating boilers.
- Self-powered, generating night light.
- The circulation of nutrient solutions will be done.
- It moderates the temperature of the building.

"Beyond creating landscaped spaces in cities for private enjoyment, the trend is to create spaces that improve the urban environment"

References

- Multidisciplinary team with extensive research experience and collaboration with industry.
- Several green roofs have been set up at the Agricultural Engineering School of the Technical University of Madrid.

IPR

- Patent applied in Spain P201330490
- International Patent applied via PCT PCT/ES2014/070242

Development stage

- Concept
- R & D
- Lab Prototype
- Industrial Prototype
- Production

Living Roof contact

Julián Briz Escribano; José María Duran Altisent
e: [julian.briz; josem.duran]@upm.es

UPM contact

Innovation, Commercialization and
Entrepreneurship Area
Centre of Support for Technological Innovation
– UPM
e: innovacion.tecnologica@upm.es



Energy & Environment

Energy & Environment

Technologies included in this area are related to energy conversion and storage, sustainable energy generation, and environmental protection and sustainable development.

BranchBiotech

Increasing bioenergy production from plants

[Link](#)

ECO-SunLight

High-efficiency, ecological and natural lighting

[Link](#)

Technical protection for the historical - cultural heritage

Portable electronic system capable of measuring the environmental acidity and facilitate preventive conservation of the historical - cultural heritage and its safety

[Link](#)

PBR-L

Biologic solutions to environmental problems and animal feeding

[Link](#)

ConecTto

Automates your electrical installation and reduces consumption for you

[Link](#)

OceTrack

Big data analysis

[Link](#)

IES CPV-SolarCell

40% efficiency in concentration solar cells

[Link](#)

CECT 13092

Better performers in biopulpeo, biobleaching and bioethanol production processes

[Link](#)

SILSTORE

Energy storage system based on silicon

[Link](#)

Energy & Environment

HERA

Highway EnERgy assessment

[Link](#)

Check Energy & Environment UPM technologies marketplace

[Website](#)

BRANCHBIOTECH. Increasing bioenergy production from plants

Biotechnology solution for accelerating the development of branches in plants: higher biomass yield

A research team from the Centre for Plant Biotechnology and Genomics (GBGP) at the Technical University of Madrid has developed a biotechnological application of a gene responsible of an accelerated and greater production of branches in ligneous species without showing changes either in their growth characteristics or in the composition and anatomy of their wood.

The challenge facing the global electricity market is managing the issue of carbon emissions with growing nations needing power. Obtaining bioenergy from plants could help to alleviate the effects of global warming and energy safety problems, provided that high yields can be sustained. The possibility of generating trees with a greater biomass by manipulating genes makes transgenic plants preferred candidates for bioenergy production. Biomass is simple and cost effective with some estimations predicting that by 2050, it could provide 50% of the world's primary energy needs. Biomass combustion technologies are fully mature with high commercial availability and a multitude of options for integration with existing infrastructure at both large and small-scale levels.

Technology solution supported by the Technical University of Madrid

Technology solution

The lateral buds of most temperate woody species do not grow out during the season in which they form. These proleptic buds overwinter and grow out during the following spring. However, in poplar and a few other temperate species, as well as many tropical species, some lateral buds grow out sylleptically, that is, they grow out during the same season in which they form without an intervening rest period. Sylleptic branching may increase significantly branch number, leaf area and the general growth of the tree, particularly in its early years.

This solution consists of biotechnological application of the RAV1 gene (Related to ABI3 and Viviparous 1) in relation to their capacity for increasing the degree of development of sylleptic branching in ligneous species. Therefore, this tool can increase the biomass production of a forestry plantation genetically modified in this manner. This application is of great interest in various industrial sectors, such as energy industry or the chemical one.

Areas of application

- **Energy:** biomass production.
- **Biotechnology:** biotechnology and forestry practice.

"Biotechnology applied in perennial plants: inducing branching as a profitable trait to increase biomass yield"



Market and social demands

- The sustainability potential of global biomass for energy is widely recognized. For example, the annual global primary production of biomass is equivalent to the 4,500 EJ (1 EJ=10¹⁸J) of solar energy captured each year.
- Obtaining bioenergy from plants could help to alleviate the effects of global warming and energy safety problems. In USA, the biomass power industry reduces carbon emissions by more than 30 million tons each year.
- The sustainable use of biomass as an energy source requires comprehensive management of natural resources such as land and water. Unsustainable biomass production would erode the climate-related environmental advantage of bioenergy.
- Currently, the amount of land devoted to growing energy crops for biomass fuels is only 0.19% of the world's total land area and only 0.5-1.7% of global agricultural land. According to estimations, a mere 10% increase in the efficiency of biomass production through irrigation, manufacturing, fertilizing or improved management through the cultivation of idle land, would create energy equivalent to the total current global energy demand [Swedish University of Agricultural Sciences].
- Biomass market lacks methods and standards for monitoring feedstock quality, which adds to the costs of collection, transportation, and storage of feedstock to the site of power plants.

Market potential

- Global biomass power capacity will reach minimum 86 GW globally by 2021 from 58 GW in 2011, which represents a staggering growth of almost 50% [Pike Research].
- Total investment in the biomass sector between 2008 and 2021 would have reached a sum of \$104 billion [Pike Research].
- Biomass installations present a more attractive investment than other renewable energies. The major portion of interest is directed at biomass with 37% interested in investment of all renewable energies [KPMG].
- Estimations predict that by 2050, biomass could provide 50% of the world's primary energy needs. [Business Insight].
- Great growth in the trade of biomass commodities (biodiesel, fuel ethanol...): international trade volume increased by a factor of 10 between 2000 and 2010 [Bioenergytrade.org].
- Forest products global industry is recovering from the economic crisis, with the Asia-Pacific region and particularly China taking the lead. On average global production grew by 1-4% in 2011 compared to 2010. China is increasing its importance as producer of forest products, becoming the world's second largest producer of sawnwood after USA [FAO].

Competitive advantages

- Accelerated development of sylleptic branching while the plants are young to increase biomass production of a forestry plantation: costs reduction in raw material production.
- Alternative application as timber logging, increasing both wood quality and forestry efficiency: reduction in the number of nodes in the trunk of high value limber ligneous species.
- Multi-application solution in industrial sectors of great economic impact: energy, chemical, silvicultural, paper industries.
- Potentially applicable to any genotype of a ligneous species: allow taking advantage of this genotype to a specific habitat.
- Required forestry plantations can be established in surplus marginal or agricultural lands: no competence with the food crop for fertile soils.

“Power generation from biomass costs about €90 to €100 per MWh, more than the cost of power from cheap fossil fuels with low carbon prices. It is still necessary to make it cost competitive”

References

- Research group involved in the study of the molecular basis of cold acclimation and winter dormancy in woody plants.

IPR

- Patent granted in Spain ES2371900.
- International patent applied via PCT PCT/ES2102/070471 - WO2013/007848.
- European patent applied via EPO EP12791214.5
- Patent applied in USA 14/232.538

Development stage

- Concept
- R & D
- Lab Prototype
- Industrial Prototype
- Production

BranchBiotech contact

Isabel Allona
Centre for Plant Biotechnology and Genomics–
UPM-INIA
e: isabel.allona@upm.es

UPM contact

Innovation, Commercialization and
Entrepreneurship Area
Centre of Support for Technological Innovation
– UPM
e: innovacion.tecnologica@upm.es

ECO-SUNLIGHT. High-efficiency, ecological and natural lighting

50 % lower power consumption, longer life, 100% recyclable and high quality lamp

This new lamp, as a research result achieved by the Group for Automation in Signals and Communications at Technical University of Madrid (UPM) in collaboration with other researchers at Rey Juan Carlos University, uses 50% less energy than current incandescent lamps and competes on efficiency with LED lighting, fluorescent and discharge lamps. It is able to faithfully reproduce more than 20 million colors, just like the sun, as, instead of concentrating light emission in narrow bands of the visible spectrum, it distributes its high power over the whole spectrum. In addition to this, lamp switch life is longer in terms of on/off cycle. It is 100% recyclable and it can be designed for any power rating.

Technology solution supported by the Technical University of Madrid

Technology solution

Eco-SunLight solution is a new kind of incandescent lamp with minor energy losses and high power based on a tungsten filament's special geometry that is immersed in a gaseous iodine atmosphere. It is controlled by a small solid-state device that achieves a higher energy efficiency, more than double previous lamps efficiency.

This lamp competes on efficiency with current LED lighting, fluorescent and discharge lamps, but the latter ones show the disadvantage of concentrating its power in certain wavelengths, giving a false sense of brightness. Alternative solutions achieve energy savings emitting all their power in wavelengths and in such a suitable proportion so that human retina is more sensitive, which could harm the eyes in the long term. Instead, Eco-Sun Light lamp is more natural and healthy as it distributes its light emission continuously throughout the visible spectrum, it doesn't have emission peaks and it is able to faithfully reproduce more than 20 million colors.

"UPM and URJC researchers have developed an ecological and "solar" lighting: a long life and low energy consumption light bulb"



Areas of application

- **Energy:** energy efficient illumination.

Market needs

- **Energy efficiency**
 - High efficiency lamps, based on thermal emission.
 - Quality lighting, with good color rendering, that doesn't damage eyesight.
 - Small device, low interference and noise emission, low heat dissipation.
 - Easy handling and replacement.
- **Sustainability**
 - Non-polluting and respectful environment low cost product.

Eco-SunLight highlights are energy-efficient lighting (it duplicates incandescent lamps efficiency indeed), high quality, long-life and low cost production



Competitive advantages

- Ignition lamp that duplicates the efficiency of the rest of the lamps based on incandescence.
- Possible substitute product for applications that require low power consumption but higher quality, ease of handling and a small size.
- More natural and "healthy" lighting, compared to alternative solutions, by distributing its light emission throughout the whole spectrum.
- 100% recyclable.
- Possible design to any kind of power rating.
- Over 20 million colors faithful reproduction.
- Possible substitute product of current incandescent lamps according to new regulations.
- Safe for the circuit in which it is used, particularly for switches.

Market potential

- Energy-efficient lighting industry is likely to sell 2.5 billion units by 2020 growing at a CAGR of 12.5% from 2012 [Energy-efficient Lighting Market in Europe to 2020].
- World demand for lighting is projected to grow 12.3% yearly through 2016 to \$78.3 billion. Gains will be boosted by an ongoing shift to higher value lighting technologies that are more efficient [RnRMarketResearch.com].
- Just in Spain, incandescent and substitutes lamps (like EcoSunLight) sales overcome 50 million units per year.

References

- Research team within Group for Automation in Signals and Communications (GASC-UPM), headed by Dr. Diego Andina, specialized in multidisciplinary applications of new technologies. Research lines include signal processing, circuits design and simulation of complex systems.
- Participation in more than 60 projects in collaboration with companies, co-funded by the European Union or national agencies, and regular provision of technological services to companies.
- 4 patented inventions; 2 spin-offs.

IPR

- Patent granted in Spain ES2416580

Development stage

- Concept
- R&D
- Lab-Prototype
- Industrial-Prototype
- Production

Eco-SunLight contact

Juan Jiménez, Diego Andina
e: juan.jimenez@upm.es, d.andina@upm.es
ETS Telecommunications Engineering – UPM

UPM contact

Innovation, Commercialization and
Entrepreneurship Area
Centre of Support for Technological Innovation –
UPM
e: innovacion.tecnologica@upm.es

Technical protection for the historical. Cultural heritage

Portable electronic system capable of measuring the environmental acidity and facilitate preventive conservation of the historical - cultural heritage and its safety

Researchers from the Technical University of Madrid (UPM) have collaborated with the Spanish National Research Council (CSIC) for the development of an innovative electronic system able to measure and monitor environmental acidity (pH) in the air. The acidity is responsible, in specific circumstances, of chemical attacks against materials and living organisms. The main characteristics of the solution (tested in real environments) are the low cost of production, not-energy consumption and minimum installation requirements. Initially developed as a solution for conservation of the historical - cultural heritage, the system has potential applications in the chemical, food processing and environmental industry, among others.

Technology solution supported by the Technical University of Madrid

Technology solution

The solution is a portable electronic system for automatic determination of environmental acidity (pH) in any state of matter, liquid or solid damp and also gas (e.g. air).

The data capture component is based on the technology of sol-gel optical sensors capable of assessing environmental conditions of acidity. This optical response is measured by reading units, quantified and converted to an electrical signal that can be processed to monitor optimally and remotely, environmental acidity.

Compared to conventional systems, the proposed sensor system is a global pioneer in measuring the pH in the air in both open and closed environments.

"The application of innovative technologies for cultural heritage preservation is key to ensuring cultural tourism, which in Spain attracts 7.5 million foreign visitors and generates more than 6,000 million euros in revenue"

Areas of application

- ICT applied to the environment and energy efficiency
- Environment and health



Market demands

- Increasing greenhouse gas emissions (CO₂, SO₂ ...) from engine combustion or industrial processes: Total emissions for 2010 were 30.6 Gigatonnes, 5% higher than the previous record year in 2008, according to an International Energy Agency
- In combination with the ambient humidity, the acidity generated can attack materials and living beings in the form of acid rain for example. In urban and industrial environments, environmental acidity (pH) is especially dangerous, with values distant from the neutral value 7.0.
- Environments generally not controlled due to installation complexity and lack of specific means.
- Much of the materials with historical and heritage interest (metals and alloys, glass, textiles, organic ...) are especially sensitive to polluted environments, as well as emissions of certain materials of the windows or exhibitors.
- In recent years, the deterioration of the properties of historical and cultural heritage has been accelerated by the increased pollution and the lack of preventive maintenance systems.
- In other industries, such as food processing, chemical, fish farming, water treatment or security, productivity and safety levels are in danger due to a lack of effective environmental control.

“The Spanish heritage is one of the largest reserves of cultural capital of the world, comprises a stock of physical goods only comparable to that of Italy or France”

Market potential

- Public and private investment in the field of conservation and management of cultural and historical heritage amounts to 1,864 M € in 2004 (0.22% of GDP) [Fundación Caja Madrid]
- Tourism contributes 5% of the world's GDP and almost 12% in the Spanish GDP. [World Travel and Tourism Council]
- Spain is the 2nd country with the largest number of property declared as World Heritage Sites. [UNESCO]
- 89% of the motivations of the cultural tourism are based on heritage tourism (museums, historic areas ...). [European Association for Tourism and Leisure Education]
- Conservation & Restoration Subsector of artistic heritage in Spain consists of 44 specialized enterprises, with a turnover of 205 M € in 2008, and more than 600 enterprises indirectly. [ARESPA].

Competitive advantages

- Innovative device capable of measuring the environmental pH in the air, both open and closed environments
- Low cost sensors (cost price € 0.1) mechanically simple and with minimal installation requirements
- No power supply required: ability to monitor for long periods of time or in remote environments.
- Small size: the base where the sensor base material is placed is 30x25 mm. It is possible to miniaturizing
- Chemical and thermal stability (-5/60 ° C)

References

- Multidisciplinary successful collaboration between the CSIC and the UPM
- Solution validated in various buildings and heritage sites (eg. Wilanów Royal Palace in Warsaw, 3,200 m² of documentary of Tomás Navarro Tomás Library – CSIC; CSIC Headquarters; Church of the Holy Spirit in Madrid, etc..).

IPR

- Patent granted in Spain ES2373138

Development stage

- Concept
- R & D
- Lab Prototype
- Industrial Prototype
- Production

Solution contact

Guillermo de Arcas, Eduardo Barrera, Juan Manuel López
e: {g.dearcas, eduardo.barrera, juanmanuel.lopez}@upm.es

UPM contact

Innovation, Commercialization and Entrepreneurship Area
Centre of Support for Technological Innovation – UPM
e: innovacion.tecnologica@upm.es

PBR-L. Biologic solutions to environmental problems and animal feeding

Laminar photobioreactor for the production of algal biomass on a large scale

PBR-L is a photobioreactor for concentrated microalgae biomass production, based on the technique of immobilized cells and specially designed for CO₂ capture and removal of nitrogen and phosphorus (eutrophication elements) in effluents from sewage treatment. It has been developed by the Agro-Energy Group of the Technical University of Madrid (UPM, Spain) and patented by UPM.

The algal biomass produced can be used for fish farming as a source of fat and protein for fish nutrition. It can also be used as a raw material of biofuels (biodiesel, bioethanol, bio-kerosene, methane).

Technology solution supported by the Technical University of Madrid

Technological solution

The PBR-L is designed for removing eutrophication elements in wastewater -mainly phosphorus and nitrogen- and for the capture of CO₂ and other flue gases from industry and transport.

In addition to the reduction and removal of these pollutants, abundant algal biomass with a number of uses and both feed and industrial applications, is produced.

Versus other present photobioreactors, PBR-L has the advantage of lower production costs and reduced energy consumption in algal biomass harvesting.

PBR-L has a modular design and easy installation, applicable to both small and large scale.

"PBR-L contributes to clean the environment while microalgal biomass is obtained simultaneously, potentially used as a raw material for the production of animal feed and biofuels"

Areas of application

- Environment:** wastewater treatment, capture of CO₂ from industrial emissions.
- Agrifood:** manufacture of compound feedingstuffs for aquaculture and animal feed.
- Energy:** biofuels production



Market demands

Environment

- Global concern about the need of reducing the concentration of nitrogen (N) and phosphorus (P) in secondary and tertiary effluents of urban and industrial wastewater treatment plants in order to prevent eutrophication of waterways and groundwater contamination. Currently in Spain only 11% of surface waters and 16% groundwaters meet the objectives of water quality set in the Water Framework Directive WFD, regarding N and P.
- Reducing global anthropogenic CO₂ emissions to the atmosphere, which -despite the Kyoto Protocol- have increased 1.7 % annually since 1990.

Agrifood

- Global interest in the eradication of hunger and in meeting the Millennium Development Goals of the United Nations MDGs .
- Being able to feed a growing population that now exceeds 7 billion people, maintaining the balance between population and resources.

Energy

- Interest in avoiding the consumption of fossil fuels by the substitution with biofuels by 10 % by 2020 .

“The need of reducing air pollution caused by greenhouse gas emissions and contaminating effluents from wastewater treatments is a problem of growing interest worldwide”

Market potential

Environment

- CO₂ emissions will increase by 130% by 2050. The investment needed to halve emissions and develop an "international energy technology revolution" will require 45,000 million dollars by 2050. [International Energy Agency].
- Member states of the EU must establish measures to ensure that effective, proportionate and dissuasive penalties are applicable to breaches of the WFD provisions [Water Framework Directive EU 2000/60/EC]

Agrifood Sector

- Marine and inland aquaculture production in Spain in 2012 generated about 30 million Euros [Ministry of Agriculture, Food and Environment].

Energy Sector

- The growth in world energy demand for the period 2013-2030 will be 32% [U.S. Energy Information Administration].

Competitive advantages

- Compared to other microalgae production systems, with this new reactor we get higher biomass production with less humidity.
- It is specially designed to admit the entrance of flue gases from engines and heating systems, optimizing the contact of these gases with the cultivation of microalgae, which promotes their absorption and increases the production of algal biomass.
- Optimal lighting of algae thanks to its laminar design.
- Natural cooling through water evaporation.
- Modular design for easy assembly, low cost and low energy requirements, which makes PBR-L an ideal solution for areas at any level of development.

References

- The Agro- Energy Group of UPM has extensive experience in R&D on biomass and environment, having developed more than 50 projects awarded in public calls, from which 29 in international calls. They have granted 5 patents plus 2 Utility Models submitted for approval.

IPR

- Patent granted in Spain ES2347515A1
- International patent applied via PCT PCT/ES2011/000104-WO2011138477
- European patent applied via EPO EP11777300,2
- Patent applied in Brazil 1120120281496
- Patent applied in Chile CL03035-2012
- Patent applied in Colombia 12-190979
- Patent applied in EE.UU. 13/695,709
- Patent applied in Israel 222834
- Patent applied in Mexico MX/a/2012/012569

Development stage

- Concept
- R & D
- Lab Prototype
- Industrial Prototype
- Production

PBR-L contact

Jesús Fernandez Gonzalez
e: j.fernandez@upm.es
Maribel Martín Girela
e: isabel.marting@upm.es

UPM contact

Innovation, Commercialization and
Entrepreneurship Area
Centre of Support for Technological Innovation
– UPM
Technical University of Madrid
e: innovacion.tecnologica@upm.es

CONECTTO. Automates your electrical installation and reduces consumption for you.

ConectTo improves the chances of control of the elements of an electrical installation and allows to understand and manage their energy consumption.

ConectTo is a technology that can save between 20 and 40% the electricity bill of the buildings through the monitoring of electrical equipment in order to diagnose any abnormal or bad habits in the use of electrical appliances and propose solutions that promotes savings and energy efficiency.

ConectTo system consists of a series of PLCs that send and receive data from a hub connected to the internet and use as a means of viewing and remote control any computer, smartphone or tablet that can connect to internet. PLCs are small devices, scalable, economic, self-configuring, wireless and are able to measure consumption. They are also compatible with existing electrical installations allowing remote control, feedback and switchboard by software.

ConectTo has been tested in the hospitality industry, achieving savings of 30% on the electricity bill.

Technology solution supported by the Technical University of Madrid

Technology solution

ConectTo is a system that improves the chances of control of the elements of an electrical installation by users and allows to understand and manage their energy consumption. The system consists of a series of PLCs that send and receive data from a hub connected to the internet and use as a means of viewing and remote control any computer, smartphone or tablet that can connect to internet.

ConectTo is an intelligent system own hardware that consists on small devices, scalable, self-configuring and wireless that are able to measure consumption and control the electrical system. The devices are inserted into the sockets, providing a point of intelligence and connectivity: electrical control, consumption meter, temperature sensor, humidity sensor or CO2 sensor.

Areas of application

- **ICT:** Application to the monitoring and control of electrical installations.
- **Energy:** application to reduce the electric bill of buildings.

"ConectTo gives intelligence to an installation by using individual control of each device and a software that recognizes the user's habits and customs to improve energy efficiency and comfort".

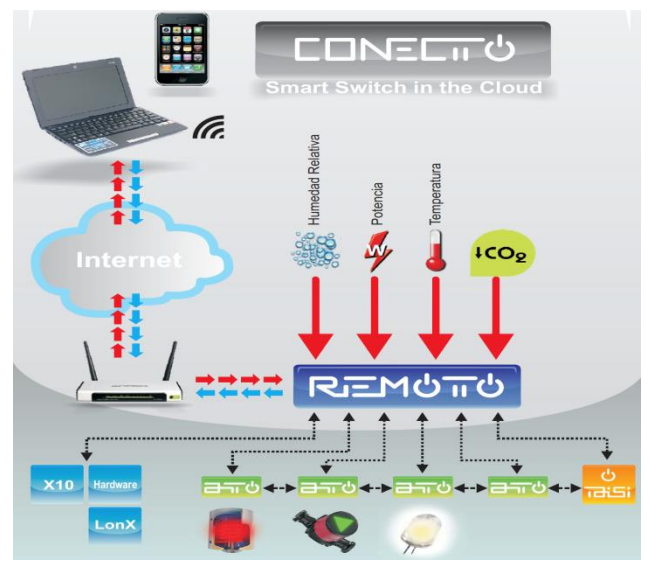

ConectTo System Operation

Market demands

ICT Sector

- Need to monitor and manage power consumption in buildings, remotely from anywhere in the world, is part of the plan of the Smart Cities and The Internet of Things.

Energy Sector

- Reduce energy bills and increase energy efficiency. According to Eurostat, since 2004 until today, the price of energy has increased by 62%.
- Identify and quantify the power consumption in the right place and time where it is occurring, associated with both the power of the equipment as to the habits and customs in the use of the equipment.
- Comply with the Kyoto Protocol begins with the awareness of the use of energy to reduce emissions of greenhouse gases that causes global warming.

"In a global context, according to ABI Research, an estimated 90 million homes worldwide, will be equipped with intelligent automation systems by 2017, generating a market of U.S. \$ 35627.83 million for 2016 with a annual growth rate of 60% between 2012 and 2017".

Market potential

ICT Sector

- In the field of home automation to control electrical appliances, national turnover was 144 million euros in 2011. Besides a marked trend is evident towards rehabilitation. Also it is expected sector growth because 50 percent of the Spanish housing stock is over 30 years old and needs renovation [Spanish Association of Automation (CEDOM)].
- The global market trend is very favorable. An estimated 90 million households worldwide will be equipped with intelligent automation systems for the year 2017 [ABI Research].

Energy Sector

- According to the European Directives in the context of Horizon 2020, the main objectives to increase energy efficiency are: 20% reduction in energy consumption, 20% of the energy produced by a country should come from Renewable Energy Sources, 20% reduction in emissions of greenhouse gases [Europe 2020].
- To obtain the prestigious LEED label in a building is necessary to have a monitoring and control system of the power consumed by different building systems [Leadership in Energy & Environmental Design].

Competitive advantages

- ConecTTo not only monitor, but diagnoses and proposes solutions aimed at saving and energy efficiency.
- Full compatibility with existing electrical installations, so you do not have to do work to implement the new devices.
- Bidirectional scalable system. The system automatically recognizes the emergence of new automata and can show in each instant the status of all devices of the installation.
- Allows switchboard through software increasing the different possibilities of use of spaces.
- ConecTTo gives intelligence to an installation using individual control of equipment and SW that recognizes the user's habits and customs to improve energy efficiency and comfort.
- Allows radio frequency remote control from anywhere in the world with any kind of internet access while preserving the option of manual control.

References

- The Monitoring and Control Project started in 2009 within the Research Group "Numerical Methods and Applications to Aerospace". Technical University of Madrid.

IPR

- Utility Model ATTO (ES U2013303378/ES1082529U).

Development stage

- Concept
- R & D
- Lab Prototype
- Industrial Prototype
- Production

ConecTTo contact

Belén Moreno Santamaría; Alejandro Fernández Sánchez; Fernando del Ama Gonzalo; Juan Antonio Hernández Ramos
e: belen.moreno@conectto.com
w: <http://www.conectto.com>

UPM contact

Innovation, Commercialization and Entrepreneurship Area
Centre of Support for Technological Innovation – UPM
e: innovacion.tecnologica@upm.es

OCETRACK. Big data analysis

Software to extract the organization of ocean currents using satelital data

We propose a software that use a global Lagrangian descriptor to locate the ocean structures that predict the movement of currents and particles such as pollutants. It has the capability of summarize gigabytes of satellite data in easy to interpretate pictures. In addition, OceTrack may be useful in the following problems: weather forecast, the evolution of buoys, nutrients, heat or salinity concentration in the ocean, particle dynamics/dispersion in the atmosphere, micro-mixing devices, etc.

Technology solution supported by the Technical University of Madrid

Technology solution

The software uses a Langrangian descriptor with the ability to provide a time dependent geometrical partition of the dynamics of a complex flow. It can be applied to arbitrarily time dependent flows and dynamical systems of arbitrary dimension. The descriptor locates zones of the flow such as vortices and eddies, and has the capability to measure the time period in which particles are confined in the inner core of these structures.

Areas of application

- **Enviroment:** the prediction of the spreading of an oil spill, leading to a fast response to protect the enviroment.
- **Safety:** the detection of places in the atmosphere and ocean with the highest probability of bigger concentration of contaminants.

"The descriptor shows the hidden skeleton of the ocean"

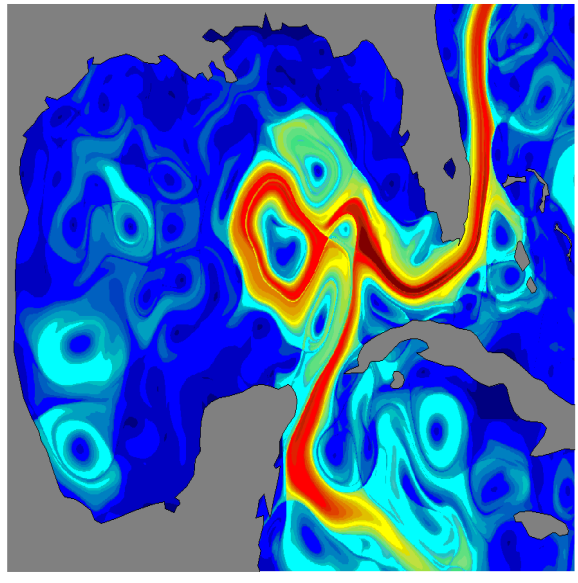

Market demands

▪ Enviroment

- The National Academy of Sciences of US in 2011 estimated that 1.7 to 8.8 million tons of oil are released into world's water every year. More than 70% of those are directly related to human activities.
- About 680 thousand tons of oil were released during the Deepwater Horizon oil spill in 2010, and about 35-40% of that oil is thought to have remained contained in the deep sea.

▪ Safety

- The most severe reduction of faunal abundance and diversity extended to 3 km in all directions, covering an area of about 24 km². The moderate impact are reached about 148 km².
- The recovery time for plankton last months, meanwhile beaches, exposed rocky shores or sheltered rocky shores lasts 1-3 years. Longer time is required for Saltmarsh ,3-5 years, and Mangroves more than 10 years. [no-for-profit organization ITOFP]
- Greater effectiveness in oil removal tends to reduce enviromental damages and socio-economic impacts.



«OceTrack finds the zones, such as vortices and currents with their boundaries, where the the pollutants are confined»

Market potential

▪ Enviroment

- As per the Clean Water Act, BP may be imposed a penalty of \$1,100 for each barrel of oil that leaked into the sea. Furthmore, the fine may be increased to \$4,300 per barrel if BP is found to be guilty of gross negligence by the US court.
- The oil companies move arround 290 billons dolars.

▪ Safety

- Spending on Clean BP is about 14 billions dolars [reuters]
- Greater effectiveness in oil removal tends to reduce enviromental damages and socioeconomic impacts.
- The Cleaning Harbors companies move 7.28 billions dolars.

Competitive advantages

- The software use an unique Lagrangian descriptor that extracts singular features of the velocity fields. It finds the hidden skeleton of the ocean currents and shows all the relevant information in one picture. The current tool used to tackle this problem, Lyapunov exponents, provides noisy results and only finds principal lines.
- The sofwtware can be applied to arbitrarily time dependent flows.
- Fast predictions in case of an oil spill
- Summarize Gigas of data in one picture.

References

- This work has been development in coloboration with *Institute of Mathematical Sciences* of CSIC, with the Group of Fluids of ICMAT, headed by Ana M. Mancho. During the last 5 years they have participated in 8 projects financed by national and international organisms.
- The group won in 2012 a competitive Severo Ochoa grant to study the earth sciences.

IPR

- Software to be registered.

Development stage

- Concept
- R & D
- Lab Prototype
- Industrial Prototype
- Production

OceTrack contact

Carolina Mendoza, Ana M. Mancho
e: carolina.mendoza@upm.es

UPM contact

Innovation, Commercialization and
Entrepreneurship Area
Centre of Support for Technological Innovation
– UPM
e: innovacion.tecnologica@upm.es

IES CPV Multijunction Solar Cell. 40% efficiency in concentration solar cells

Triple junction concentration solar cells allowing to reach competitive prices for photovoltaic electricity working effectively at high concentration levels.

The triple junction concentration solar cell able to reach an efficiency up to 40% has been developed by the III-V Semiconductors Group at the Institute of Solar Energy of the Technical University of Madrid (IES-UPM).

These cells allow to reach competitive prices of photovoltaic electricity in an scenario that nowadays shows a progressive increase in the price of energy of the 62% since 2004 (source: Eurostat). Photovoltaic solar energy market is expected to be growing by 66% along the next four years.

Technology solution supported by the Technical University of Madrid

Technological solution

Multijunction solar cells are currently the most efficient photovoltaic devices. The Institute of Solar Energy has developed a triple junction solar cell with an efficiency close to 40% at a concentration of 1000 suns. This cell is formed by an upper GaInP subcell, an intermediate GaInAs cell and a lower Ge cell.

IES-UPM has devoted its wide experience in the field of high concentration to the design of this device. As a result, its performance has been optimized at irradiances higher than 1000 suns, while the impact of the series resistance and the capacity of optimal response to the lack of uniformity of illumination, produced by real optical concentrators, have been minimized.

This solar cell is still at a laboratory prototype stage. Some improvements have already been identified and it is expected to reach efficiencies up to 42% in the near future.

Market implementation sectors

- **Energy:** production of photovoltaic solar energy.

"Triple junction solar cells for concentrations higher than 1000 suns: better performance, more efficiency and competitive prices of photovoltaic solar electricity"

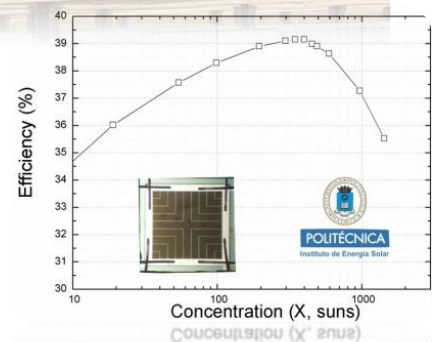

Market needs

- Global demand of energy is expected to grow by 2.2% per year until 2020, mostly in the developed world.
- The price of energy has been increased by 62% since 2004 [Eurostat].
- According to European Directives in the framework of “Europe 2020 Strategy”, main objectives to increase energy efficiency are: 20% reduction of energy consumption; 20% of the energy demand of a country supplied by renewable energy sources, 20% reduction of greenhouse gas emissions. [Europe 2020].
- The Sunbelt Countries (Africa, Middle East, Southern Asia and South America) has around 75% of the world’s population and 40% global demand of electricity [European Photovoltaic Industry Association – EPIA].

“The demand of electricity is expected to grow by 70% in the coming 15 years, while total demand of primary energy is calculated around 48%”

“Concentration photovoltaic solar energy is identified as one of the sources with the highest margin of potential improvement, driven by technological advances and efficiency gains”

Market potential

- The photovoltaic solar energy industry is currently a growing market: the number of facilities installed has increased more than 48% per year for the period 2000-2012, being Europe the promoter of the 66% of them. [Fraunhofer ISE].
- The estimated average global growth of photovoltaic plants for the period 2013-2017 is 66% [IHS].
- 2013 was a key year in the development of photovoltaic solar industry: installation of 38,4 GW plants, up from 30 GW in 2012. Europe takes a back seat in favour of Asia (China and Japan Photovoltaics remained among the most demanded energy sources in the EU, together with wind energy, in 2013. [EPIA].
- Suncore, Soitec and SunPower lead almost 80% of the global concentration photovoltaics market [IHS].
- Concentration photovoltaic solar energy (CPV) market is expected to increase the current installed power from 358 MW to 1,040 MW in the next 5 years [Global Data].

Competitive advantages

- Efficiency higher than 40% in a triple junction concentration solar cell has been reached: possibility to offer competitive prices of photovoltaic energy. Efficiencies higher than 42% at 1000 suns concentration to be reached in the near future.
- Solar cells prototype manufactured at IES-UPM facilities.
- Reliability analysis of the cell performance by accelerated life tests.

References

- IES-UPM is a cutting-edge R+D center in the field of photovoltaic solar energy, worldwide recognized.
- Broad relationship with industry, innovative career of the research team through collaborative projects, patented results and development of own software.

Industrial protection

- National Patent EP2160555 (*on the basis and procedures of solar cells for high concentration*).
- European Patent EP2556453 (*on the efficiency simulation process used with triple junction solar cells*).
- Requested Patent in the USA 2013/0275,095 (*on the efficiency simulation process used with triple junction solar cells*).

Development stage

- Concept
- R & D
- Lab Prototype
- Industrial Prototype
- Production

IES CPV-SolarCell contact

Ignacio Rey-Stolle Prado
e: irey@ies-def.upm.es
Carlos Algora del Valle
e: algora@ies-def.upm.es
w: <http://www.ies.upm.es/>

UPM contact

Innovation, Commercialization and
Entrepreneurship Area
Centre of Support for Technological Innovation
– UPM
e: innovacion.tecnologica@upm.es

CECT 13092. Better performers in biopulpeo, biobleaching and bioethanol production processes

A new strain with applications in the pulp and paper industry and the production of second generation biofuels

Researchers from Universidad Politécnica de Madrid (UPM, Spain) and Instituto Nacional de Investigación y Tecnología Agraria y Alimentaria (INIA, Spain) have isolated and characterized the fungal strain *Hormonema* sp. CECT 13092, which offers improvements when is applied to different processes of the cellulose industry, specifically in the pulping and bleaching processes in pulp and paper production, and the production of lignocellulosic ethanol during the saccharification step. Thus, in the pulp and paper production the application of the strain decreased the consumption of chemical reagents during the pulping process and increased the quality of pulps obtaining higher brightness levels during the bleaching process. Regarding to the production of bioethanol, the strain improved the production of fermentable sugars during the saccharification. The strain shows ease and stability in its cultivation and storage.

Technology solution supported by the Technical University of Madrid

Technology solution

The patented strain offers improvements in several processes of the pulp and paper industry and the production of second generation biofuels.

The application of the mentioned strain on eucalyptus chips improved the Kraft pulping process to obtain pulp and the enzymatic saccharification to obtain fermentable sugars to ethanol. Improvements were also observed in the TCF (Totally Chlorine Free) bleaching process of eucalypt Kraft pulp when the crude produced by the strain, enriched in laccase enzyme, was used. The fungus grows mainly in the form of yeast, which facilitates the homogenization of inocula and the subsequent application with respect to mycelial fungal form. The strain can be grown at room temperature in conventional media for fungi and maintains their viability at 4 ° C, which facilitates long-term storage.

Areas of application

- **Energy:** production of second generation biofuels.
- **Paper and cellulose industry:** pulp and paper, and related products.

"The strain shows advantages in terms of stability and ease of CULTURE compared with other strains traditionally used in the industry"



Market demands

Energy

- Declining oil reserves coupled with rising emissions of greenhouse gases (GHG) has led to a growing interest in the production and use of alternative fuels to current fossil fuels.
- Biofuels (ethanol and biodiesel) are one of the few renewable alternatives to replace fossil fuels in the transport sector in the short term [CIEMAT].
- Alternatively to the 1st generation ethanol produced from sugar and starchy biomass, the 2nd generation ethanol uses lignocellulosic biomass as feedstock, including non-food waste materials plentiful and cheap from agricultural, forestry and industrial activities.

Paper and cellulose industry

- The manufacture of pulp, paper and related products is one of the main industrial uses of lignocellulosic biomass globally.
- The progressive paper adaptation to new needs such as paper packaging, hygienic and sanitary papers, specialty papers, etc., has increased the global demand for paper by an average of 4.7% by year in the last 40 years [ASPAPPEL].

“The need to reduce GHG emissions and develop alternatives to oil has led to a growing interest in the production and use of biofuels”

Market potential

Energy

- The development of biofuels is a priority in the energy policy of the European Union, setting a target of a share of biofuels and other renewable fuels by 10% within the transport sector by 2020 [Directive 2009/28/EC, 2009].
- Spain has proposed a contribution to the target of 9.2% biofuels in the transport sector by 2020 [Renewable Energy Plan, 2011].

Paper and cellulose industry

- The European Union is the second largest producer of pulp and paper, representing wood-pulp-print chain around 10% of its industrial activity [Confederation of European Paper Industries].
- Within the European Union, Spain is the sixth largest producer of pulp and paper [ASPAPPEL].

Competitive advantages

- **BIOPULPING:** Compared to the control without fungal treatment, the new strain permitted to obtain an improvement in the delignification during the Kraft pulping of 26.7%. In the same way, the final brightness (% ISO) of the Kraft pulp was 8.3 points higher. It was also possible to reduce the consumption of NaOH during the pulping by 9%, not observing a reduction in the mechanical properties of the obtained pulps.
- **BIOFUELS:** The patented strain permitted to increase the saccharification yields by 33%. This improvement was increased when an autohydrolysis pretreatment was applied prior to the fungal treatment, increasing the saccharification yields by 204%.
- **TCF BLEACHING:** The application of the enzymatic crude prior to the TCF bleaching sequence improved the delignification by 5% and increased the brightness (% ISO) 3,3 points.

References

- The research groups involved are specialized in the development of biotechnological applications of symbiotic fungi and the development of more efficient and environmentally friendly processes for the pulp and paper industry.

IPR

- Patent applied in Spain [P201430065]

Development stage

- Concept
- R & D
- Lab Prototype
- Industrial Prototype
- Production

CECT 13092 contact

Juan Antonio Martin García
e: juan.martin.garcia@upm.es
David Macaya Sanz
e: david.macaya.sanz@upm.es

UPM contact

Innovation, Commercialization and
Entrepreneurship Area
Centre of Support for Technological Innovation
– UPM
e: innovacion.tecnologica@upm.es

SILSTORE. Energy storage system based on silicon

System that stores electricity in the form of silicon latent heat and converts it back to electricity by means of thermo-photovoltaic converters

The global consumption of electricity is expected to grow by over 60% from 2011 to 2030. Developing solutions based on abundant and environment friendly materials is the key challenge of the energy storage technologies of the future. Researchers from the Universidad Politécnica de Madrid, have developed SILSTORE, a new system that stores electricity in the form of silicon latent heat and converts it back to electricity by means of thermo-photovoltaic converters. SILSTORE has the potential to provide higher energy densities than any other electrical storage system (e.g. batteries) at very competitive costs.

Technology solution supported by the Technical University of Madrid

Technology solution

The low cost and the extremely high latent heat of silicon (more than 10 times greater than that of the materials currently evaluated for thermal energy storage – TES) makes this element the ideal candidate for TES.

However, its very high melting point (1400°C) makes it difficult to use conventional heat engines for power production.

SILSTORE addresses this challenge by using thermo-photovoltaic (TPV) converters, which provide a contactless solution to produce electricity directly from radiant heat. TPV technology enables extremely high temperature operation, high efficiency and very high power density (power-to-weight ratio).

As a result, this technology may provide higher energy densities than any other electrical storage system (e.g. batteries) at very competitive costs.

Areas of application

- **Energy:** storage of energy (homes, utilities, industry, ...)
- **Transport:** energy storage in electric/hybrid vehicles

"SILSTORE may provide higher energy densities than any other electrical storage system (e.g. batteries) at very competitive costs"

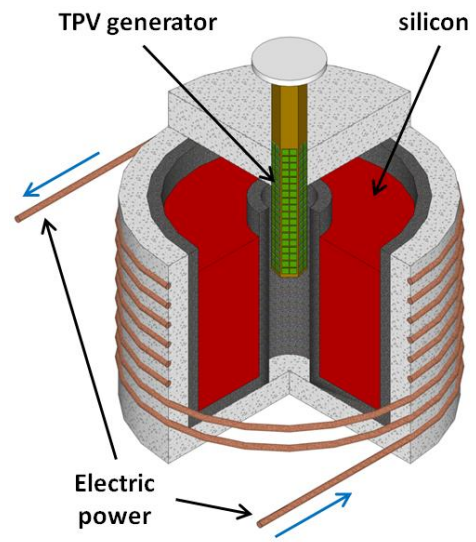

Market demands

Low cost

- *High energy density.* Particularly relevant in transport industry, high energy-to-weight and energy-to-volume ratios also enable reducing the requirements on the constitutive materials; thus reducing the final cost.
- *Low-cost.* Abundant and safe constitutive materials.
- *Modularity.* Allows reduction of cost, augmentation and flexibility in the design. Currently, this demand comes mostly from TES technologies used in the concentrating solar power (CSP) systems.
- *Location independence.* Most of the current energy storage technologies have location concerns, either because of safety reasons or because they need natural resources (e.g. water).

Low environment impact

- Developing solutions based on abundant and environment friendly materials is the key challenge of the energy storage technologies of the future.

“Developing solutions based on abundant and environment friendly materials is the key challenge of the energy storage technologies of the future [...] SILSTORE is based on silicon, the most abundant rock-forming element on earth after oxygen”

Market potential

- Globally, the advanced energy storage systems market that includes grid storage and transportation is expected to grow at a CAGR of 10% in from 2013 to reach over \$10.8 billion by 2018. The key growth drivers include growing renewable implementation, new transmission and distribution grid construction and upgrades, smart grid installation, and growing demand for electric and hybrid vehicles [marketsandmarkets.com, 2013]
- IMS Research report forecasts that the market for storing power generated by solar will soar from approximately \$200 million in 2012 to \$19 billion by 2017.
- The demand in the global advanced energy storage systems market is expected to grow to 32,000 TWh by 2035, a 70% increase from 2012. The global consumption of electricity is expected to grow by over 60% from 2011 to 2030. This huge rise in demand has to be met by increased power generation which requires 6,000 GW of added new capacity, apart from the existing capacity [marketsandmarkets.com, 2013].
- China, India, the European Union and the United States alone should invest at least USD 380 billion in new electricity storage capacity by 2050 to support decarbonisation [International Energy Agency report, 2014].

Competitive advantages

- Extremely dense energy storage: up to 500 kWh/m³ and 250 kWh/ton (see Figure).
- Based on silicon, the most abundant rock-forming element on earth after oxygen.
- *SILSTORE* technology has the potential to become one of the most cost-effective solutions in the market, mainly due to the low cost of silicon (1.3€/kg).
- Modular and scalable: it can be used in both low-power (homes, vehicles, etc) and high-power (wind turbines, solar power plants, grid management, etc) applications.

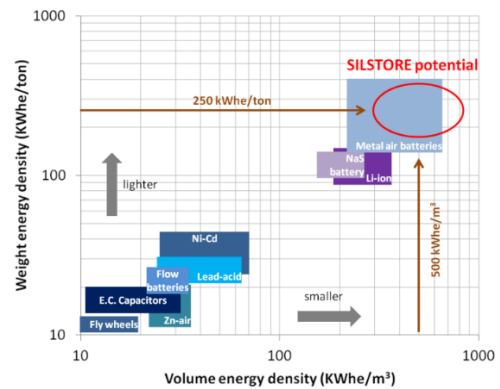

References

- IES-UPM is a cutting-edge R&D center in the field of photovoltaic solar energy, worldwide recognized.
- Broad relationship with industry.

IPR

- Patent applied in USA [US14/198,142]

Development stage

- Concept
- R & D
- Lab Prototype
- Industrial Prototype
- Production

SILSTORE contact

Alejandro Datas
e: a.datas@ies-def.upm.es
Instituto de Energía Solar (IES-UPM)
w: <http://www.ies.upm.es>

UPM contact

Innovation, Commercialization and
Entrepreneurship Area
Centre of Support for Technological Innovation –
UPM
e: innovacion.tecnologica@upm.es

HERA. Highway Energy Assessment

A comprehensive tool for estimating Greenhouse Gas (GHG) emissions and energy consumption of the traffic flows in highways

TRANSyT –the Transport Research Centre of UPM- has developed HERA, a software tool to estimate the annual energy and carbon footprints of traffic flows for a specific stretch of highway or an entire network. It also allows calculating energy savings associated to new measures and comparison of scenarios, looking for energy efficiency strategies.

HERA has multiple applications such as environmental impact assessment of road projects: to include GHG emissions impacts and analysis of alternatives from the footprint efficiency point of view; carbon-efficient design of roads for their operational phase: to optimize the footprint of traffic based on the design phase, i.e. alignment, gradient; road operation: to design traffic management strategies which minimize GHG emissions and energy consumption generated by traffic: speed, HDV control, etc.

Technology solution supported by the Technical University of Madrid

Technology solution

HERA is software dedicated to assess the energy consumption and GHG emissions of roads traffic.

It incorporates two models for different conditions: free flow conditions and toll plazas.

In contrast to other modeling approaches, HERA is valid for every country or region and for every road segment or network.

It has the possibility of comparing several scenarios or road alternatives. The input data and results could be import or export from geo-references databases.

HERA is of particular interest for assessing alternatives and strategies focused on alignment design, speed adjustment, traffic flow management or fleet composition.

Areas of application

- **Transport**
 - Environmental Impact Assessment of road projects.
 - Carbon-efficient design of roads for their operational phase.
 - Efficient road operation

“HERA supports planning and decision-making strategies towards energy efficiency and low-carbon road traffic”

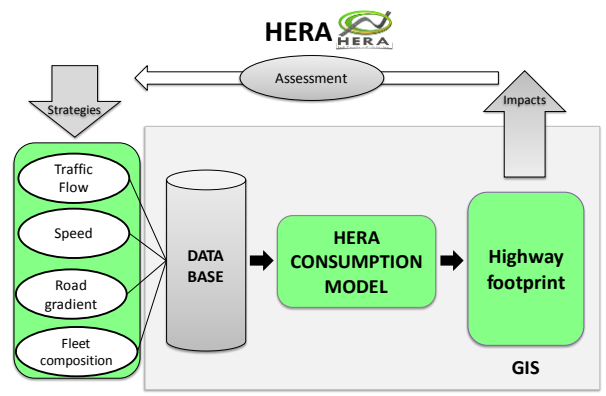

Market demands

Transport

- Kyoto Protocol, energy efficiency plans... Assessment tools are needed to evaluate abatement strategies in road transport seeking to reduce climate change impacts.
- Carbon footprint assessment of the entire life cycle of the road is becoming under regulation in many countries, i.e. in Spain the new Environmental Assessment Law, 2013.



“Improving the alignment of a hilly road could result in 13.7% of annual carbon footprint savings”

Market potential

Transport

- Link level assessment: Currently, there are many software-based tools to estimate emissions and energy consumption of traffic (COPERT, TREMOVE, etc). But, they are usually based on aggregated data and don't include the link level assessment.
- Road Administrations: to assist with decision-making towards energy efficiency and low carbon actions of road traffic.
- Consultants for: environmental management, quantification of carbon footprint along the road network, assessment of traffic management strategies, identification of most polluting stretches (so called “hot spots”)...

Competitive advantages

- Scale- HERA can be applied to any highway network in any location following a segment-by-segment approach.
- Toll plazas - apart from free flow conditions, HERA assess footprint at toll plazas evaluating the energy consumption of different collection systems: manual, electronic toll collection and open road tolling.
- Transport policy measures could be better managed and evaluated with HERA: speed management, fleet renewal, heavy duty vehicles flows, road design (gradient) and toll collection systems.
- HERA produces geo-referenced outputs: annual carbon and energy footprints (CO₂eq/year and MJ/year).
- The system has an interface to link its input/outputs with a GIS, providing geographic representation of the energy consumption and carbon footprint.

“Speed reduction of light vehicles by 10km/h could save 4.5% of annual carbon footprint of traffic”

References

- TRANSyT is a center launched in 2004 by the UPM with the aim to serve as a bridge between UPM and transport authorities, industry and society interested in the subject.
- HERA www.hera.transyt.upm.es

IPR

- Software registration M-950112013

Development stage

- Concept
- R & D
- Lab Prototype
- Industrial Prototype
- Production

HERA contact

Andres Monzón; Natalia Sobrino; Sara Hernández
TRANSyT –Transport Research Center - UPM
e: transyt@upm.es
w: www.transyt.upm.es

UPM contact

Innovation, Commercialization and Entrepreneurship Area
Centre of Support for Technological Innovation – UPM
e: innovacion.tecnologica@upm.es

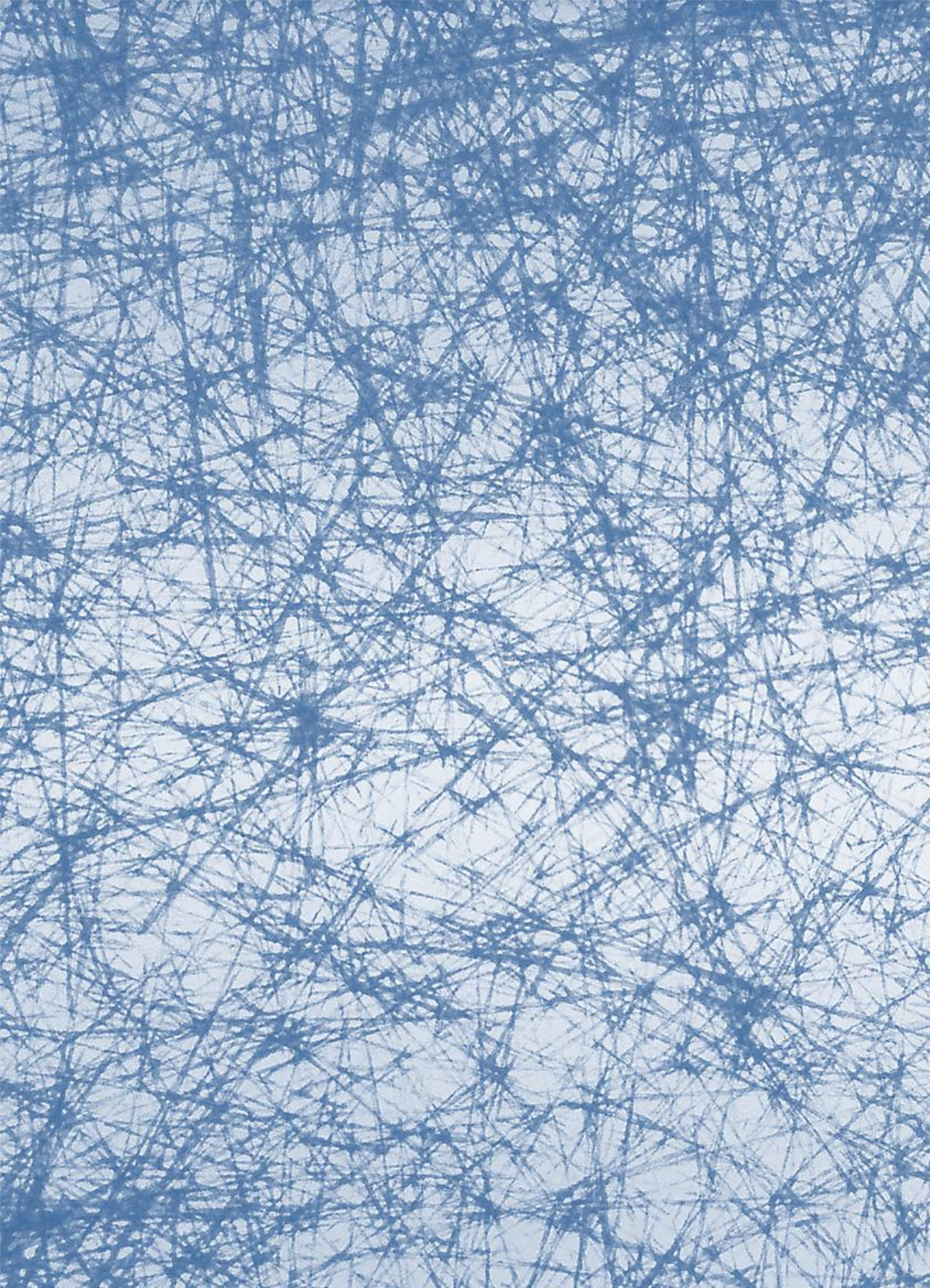

Health

Health

These technology-based solutions have been developed to solve health problems and improve people's quality of life. Also, health 2.0 technologies, such as ICT applied to health, ageing and inclusion, are included.

Glottex®

Your voice treats you, your voice identifies you

[Link](#)

Ophthalmologic kit

Reducing risks in the retinal detachment treatment

[Link](#)

Tracheo4Life

Highest reliability for emergency tracheotomies

[Link](#)

D-HOUSE

The co-management of diabetic patients

[Link](#)

Mood Monitor

Telemonitoring platform to assess mood disorders

[Link](#)

TELMA

A new technology enhanced learning environment for Minimally Invasive Surgery (MIS)

[Link](#)

AudioMC

The ultimate method for objective audiometric test

[Link](#)

Artificial pancreas

Advanced control of blood glucose

[Link](#)

GameCare

Lose weight the healthy way

[Link](#)

Biolasersports

Improved sports performance at the highest level

[Link](#)

LST Box

A box full of services for better living

[Link](#)

Health

CardioRehab

A personalized system for cardiac rehabilitation at home

[Link](#)

GPR device

Because you and your health are the first

[Link](#)

HF Management

System of monitoring and management of heart failure

[Link](#)

Parkinson-Monitor

Monitoring and follow-up of patients with Parkinson's disease and Parkinsonism

[Link](#)

Dalemov

Cognitive stimulation therapy oriented to people with Parkinson's

[Link](#)

Health-mate

Healthy Lifestyle Manager

[Link](#)

DOSIRAD

Measuring the levels of electromagnetic radiation

[Link](#)

CAD

Method to determine the prognosis of patients suffering from Pulmonary Embolism

[Link](#)

SFS

A new production technology for high performance silk biomaterials

[Link](#)

Check Health UPM technologies marketplace

[Website](#)

GLOTTEX®. Your voice treats you, your voice identifies you

Innovative biometric application for the early detection of voice pathologies and security

Glottex Voice Analysis System® is an advanced voice analysis product for the biometrics identification, result of over 15 years of R&D of a team from the School of Computing of the Technical University of Madrid.

In its health version, is currently applied for the early detection of pathologies voice and laryngeal cancer, as well as medical treatment and rehabilitation, in different hospitals in Madrid. Another line of development with high-impact is based on the identification of initial symptoms of neurological diseases such as Alzheimer or Parkinson. Moreover, and as a security application, Glottex is used by one of the Spanish security forces for forensic identification by voice.

Technology solution supported by the Technical University of Madrid

Technology solution

Glottex Voice Analysis System®, Glottex onwards, is a software application for advanced analysis of the voice and the determination of the sample closest to the biometric voiceprint.

This new solution identifies, with much more reliability, unique voice characteristics distinguishing those derived from the vocal tract (pharynx, oral cavity, nasal cavity) from those of the excitation source of the voice. Glottex is able to assess and extract unique physiological parameters from the glottal source - part of the larynx that is limited by the vocal cords and whose vibration generates the voice - .

This represents a unique technological solution able to identify early detection for voice pathology, its treatment or even identify a person biometrically

Areas of application

- **Health:** support for the early detection of voice pathologies, including larynx cancer symptoms or neurological disorders.
- **Security:** forensics, biometrics for user identification and verification.

“Glottex is able to determine the closest voice print from the glottal waveform”



Market and social demands

Health

- Voice disorders affect 5% of the world population, with a higher incidence among young people and professional groups dependent on the use of voice. Early detection is a key factor for treatment.
- Laryngeal cancer affected 150.000 persons in 2008, with a very out-standing degree of mortality and incidence increasing (Spain, at the top European level). The hoarseness of voice is one of the main symptoms of this cancer.
- According to the World Health Organization, an estimated population of 6.8 million people worldwide dies each year as a result of neurological disorders.

Security

- Global interest increasing for trustworthy biometric solutions and of difficult impostation (new and sophisticated threats for the safety).
- The safe management of digital identity is critical in numerous niche markets, with sales volumes rising (e.g. mobile banking).
- The security and intelligence departments analyze conversations related to crimes with increasing frequency. Nowadays, it is more difficult to identify suspects with traditional methods.

"It is well known the growing demand for biometric technologies to ensure reliability and low cost of implementation. Remote voice identification is getting maximum attention"

Market potential

Health

- Demand for new innovative and low-cost methods for diagnosis diseases.
- European medical technology industry (2007): € 72.6 billion sales revenues; 15% annual growth rate [Eucomed].

Security

- The turnover associated with voice biometrics is doubled in the period 2011-2014. This year, it is expected a volume of \$ 260 million market with a market share growth of 16% [Opus Research].
- Innovative technological advances have relaunched the evolution of forensic research sector through a better cost.
- The market for forensic products and services in the U.S. represent \$ 10.3 thousand million [BCC Research].

Competitive advantages

- Support for reliable and early detection of voice pathology through a pioneer analysis based on scientific and technological advances.
- R&D ongoing that could allow identify early symptoms of neurological diseases prematurely.
- Low cost of implementation in health systems: software customizable, no specific hardware requirements. 50% savings cost per patient (estimations made by medical professionals that already use Glottex).
- Non-invasive diagnostic technique, fast and without side-effects for the patient. 50% savings in time per patient (estimations made by medical professionals that already use Glottex).
- Maximum reliability in biometric identification of people.
- Very simple and low cost incorporation to the already existing voice equipment.
- Biometric technology enabling remote authentication.
- Positive market research regarding the acceptance of biometric technology users.

References

- Hospital Universitario Gregorio Marañón de Madrid.
- Guardia Civil – España.

IPR

- Patent granted in Spain ES2364401
- International patent applied via PCT PCT/ES2012/000137-WO2013001109.
- Patent applied in USA US 14/127,202
- Software registration M-006038/2008

Development stage

- Concept
- R & D
- Lab-Prototype
- Industrial Prototype
- Production

Glottex contact (spin-off BiometroSoft)

Pedro Gómez Vilda, Victoria Rodellar Biarge
e: pedro@pino.datsi.fi.upm.es

UPM contact

Innovation, Commercialization and
Entrepreneurship Area
Centre of Support for Technological Innovation –
UPM
e: innovacion.tecnologica@upm.es

UPM
spin-off

OPHTHALMOLOGIC KIT. Reducing risks in the retinal detachment treatment

Patented ocular device that optimizes the accuracy of retinal detachment surgical operations, reducing risks and improving patient well-being

A research group of the Center of Biomedical Technology (CTB) at the Technical University of Madrid (UPM) has developed an innovative solution to improve the efficiency of the retinal detachment surgery, both potential medical costs resulting from the treatment and patients welfare, in collaboration with researchers and doctors of University Hospital Ramón y Cajal, Universidad Autónoma de Madrid and the Biomedical Research Networking center in Bioengineering, Biomaterials and Nanomedicine. Applying nanotechnology in the field of biomedicine, this patented device has already been successfully tested in animals with a success rate over 80%, proving the expected benefits in terms of reducing the likelihood of new surgical operations, side effects and post-surgical recovery time. The global market for ophthalmologic surgical equipment is expected to increase to 7.300 M€ in 2014, an average compound annual growth rate of 6% during the last few years.

Technology solution supported by Universidad Politécnica of Madrid

Technology solution

This solution provides a magnetic ocular implant, a ferrofluid and a methodology for using in the retinal detachment treatment and other eye disorders. Magnetic nanoparticles, which remain in suspension in this ferrofluid, are used as a tamponade agent after their intraocular injection and location in the outer layer of the eye through magnetic field.

The appropriate dosage and introduction of ferrofluid, which interacts magnetically with the implant, allows a more reliable and adequate arrangement of the retina after its detachment, reducing risk of side effects and additional operations and shortening the post-surgical recovery time.

Areas of application

- **Health:** ophthalmology; surgery; biomedicine and bioinstrumentation; veterinary medicine.

A new worldwide ocular device applying nanotechnologies to improve both retinal detachment surgery performance and patient welfare

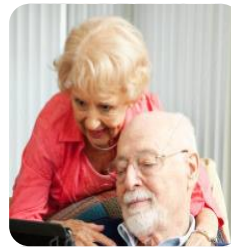

Market demands

- The rapidly population aging leads to a fast population growth over 65 years, the sector with the highest incidence of eye diseases and disorders [BBC Research].
- High incidence of retinal detachment (epidemiological approaches indicate one case per 10.000 population per year): this surgical operation is one of the most common ophthalmological procedures.
- Around 50% of these cases need to have a second surgical procedure.
- Need for specific and uncomfortable patient positionings during the most common surgery: eye incisions for the retina reattachment and later injection of substance for sealing off the hole after detachment.
- Alternative solutions (gas or silicone retinal tamponade agents after surgery) have significant side effects and could lead to medical complications: risk factors for retinal re-detachment because of a very specific rehabilitation protocol in terms of patient positionings.

“Ophthalmologic procedures require millimeter precision and are needed for real advances in the surgical equipment... a healthcare industry that would reach 7.300 M€ in 2014”

“Innovation Award in 12th EURETINA International Congress (Milan, Italy)”

Market potential

- Changing trends in diets, lifestyle, and increased longevity are growing the global market for ophthalmic devices and treatments: it is expected to reach 28.000 M\$ in 2016, with a compound annual growth rate (CAGR) of 2.5% until 2016. Surgical procedures currently represents a leading division for this industry [GBI Research].
- By 2014, ophthalmic surgical equipment industry would be valued at 7.300 M€, a CAGR of 5,9% [BCC Research].
- 3 priority healthcare areas impacted by this solution: electromedical and medical technology; medical and surgical materials; and prostheses and implants.
- In Europe, medical technology market size is estimated at 100 B€, employing 575.000 people and being driven by 25.000 medtech companies, the majority of which, around 95%, are small and micro-sized companies [Eucomed and EuroStat].

Competitive advantages

- Increase retinal detachment surgery and other eye disorders treatment success rate: medical and surgical equipment cost savings.
- Increase patient comfort and safety after the operation: higher tamponade agent placement accuracy in the retinal detachment area and lower risk of side effects such as cataracts or inflammation.
- Device already tested in animals with a success rate over 80%.
- Additional use as a surgical aid auxiliary (subretinal fluid drainage).
- Ability to place other substances into the device (drugs, proteins ...) in order to shorten the patient recovery time or protect him from infections.

References

- Top level multidisciplinary collaboration in the field of medical engineering: Center of Biomedical Technology (CTB)– UPM, University Hospital Ramón y Cajal, Universidad Autónoma de Madrid and the Biomedical Research Networking center in Bioengineering, Biomaterials and Nanomedicine.
- Innovation Award EURETINA 2012 (12th EURETINA International Congress, Milan, Italy).

IPR

- Patent granted in Spain ES2370014
- Patent applied in USA US 13/534,583.

Development stage

- Concept
- R & D
- Lab-Prototype
- Industrial Prototype
- Production

Ophthalmologic Kit contact

José Javier Serrano Olmedo
Center of Biomedical Technology (CTB)– UPM
e: josejavier.serrano@upm.es
w: <http://www.ctb.upm.es>

UPM contact

Innovation, Commercialization and
Entrepreneurship Area
Centre of Support for Technological Innovation –
UPM
e: innovacion.tecnologica@upm.es

TRACHEO4LIFE. Highest reliability for emergency tracheotomies

Device for tracheotomies assisted performance, both emergency and elective ones: life-saving surgical operations and patient safety

Complications and mortality associated with tracheotomy are mostly avoidable if the procedure is carefully performed. Post-tracheostomy complication rates are found to be significantly higher in emergency tracheotomy than in elective one (2 or 5 times higher). In these situations, patient's condition could be a critical difficulty for surgical operation because of patient's anxiety and sudden movements.

Tracheo4Life combines in a single device imaging systems for a medical diagnosis and mechanical means for patient's immobilization and the subsequent precise incision in the trachea, according to the anatomical characteristics of the case. This innovative device has been the result of multidisciplinary cooperation between a research team from the Technical University of Madrid and health-care professionals from Universidad Autónoma de Madrid.

Technology solution supported by the Technical University of Madrid

Technology solution

This solution provides a new device for performing tracheotomies, both emergency and elective ones, which enhances the effectiveness of the surgery and patient's safety, particularly in those situations requiring a faster medical operation.

To this end, the device includes:

- an image processing system for medical diagnosis and most suitable placement of tracheal incision;
- mechanical devices to prevent patient's neck area from moving;
- mechanisms for an effective tracheal incision in order to maintain an effective airway, and;
- a control unit for information processing for the purpose of adapting medical procedure to patient's anatomical characteristics.

Areas of application

- **Health:** medical devices for assisted surgical procedures (tracheotomies).

"Tracheo4Life combines medical imaging systems, an effective stabilization method of the patient, a precise mechanism for the tracheal incision and a control unit in a single device"



Market and social demands

- Around 10% of mechanically ventilated critically ill patients receive a tracheotomy to facilitate prolonged airway and ventilatory support.
- Complication rates associated with tracheotomy have been reported to range from 15-40%; the mortality rate related to tracheotomy is reported to be less than 2%. Mortality is caused, among other factors, by the blockage of the tube to be inserted or its displacement.
- Complications and mortality associated with tracheotomy are mostly avoidable if the procedure is carefully performed. Post-tracheotomy complication rates are found to be significantly higher in emergency tracheotomy than in elective one (2 or 5 times higher).
- Urgent tracheotomies:
 - Urgent tracheotomies can not be usually performed in controlled environments, with the patient under local anesthesia. The awake patient could contribute to this topic negatively, as the patient's anxiety and movements challenge the whole surgeon.
 - The risk of pneumothorax is highly increased in patients with abnormal work of breathing.
 - Urgent awake tracheotomies imply the necessity of fast and simple techniques, that may be easily learned and performed with minimal assistance.



“Tracheo4Life represents an essential advance to improve the reliability of emergency tracheotomies, such a critical

surgery in terms of complications and patient safety”

Market potential

- Global respiratory care equipment and supplies market is estimated to reach \$11 billion by 2017, growing at a CAGR of 8.8% from 2010-2015. The therapeutics devices market dominates the global respiratory care market, followed by monitoring devices and disposables, including tracheotomy devices [Global Industry Analysts Inc.]
- USA, Western Europe and Japan dominate the world's consumption of medical devices (USA, 41%) [Frost].
- Many emerging markets are witnessing annual medical device consumption growth rates of 15-20% (China, India, Brazil, Mexico), while most established markets are stuck at growth rates between 5-7% [Frost].

Competitive advantages

- The combined application of medical imaging tools with medical procedures set to the patient's characteristics, provides a solution that minimizes the risks associated with emergency tracheotomies, a feature not offered by commercial devices being marketed nowadays.
- Compact, easy to use, accurate and safe:
 - tools for providing a previous diagnosis that fits the path of the cannula and the incision to the patient's anatomy;
 - elements for securing the placement of the device on the patient's neck, clavicles and upper chest, enabling patient immobilization;
 - a portable medical imaging camera that contributes to the diagnosis and the execution of the diagnosis: a medical probe should be held to the patient's neck to define the location of the tracheal air column and the tracheal rings, as well as arteries, veins and other anatomical structures of the neck;
 - a control unit to manage the information provided by the camera in order to analyze patient anatomy and set properly some factors related to the incision procedure through control signals.

References

- Multidisciplinary cooperation between top researchers and health-care professionals.
- UPM research team, co-inventor of other 7 patents, including results in the health sector.

IPR

- Patent granted in Spain ES2387667

Development stage

- Concept
- R & D
- Lab Prototype
- Industrial Prototype
- Production

Tracheo4Life contact

Andrés Díaz Lantada, Pilar Lafont Morgado, José Alberto Jaén Gallego
ETS Ingenieros Industriales – UPM
e: adias@etsii.upm.es (Andrés Díaz contact)

UPM contact

Innovation, Commercialization and Entrepreneurship Area
Centre of Support for Technological Innovation – UPM
e: innovacion.tecnologica@upm.es

D-HOUSE. The co-management of diabetic patients

Technologies and process-centred approach are facilitators to enable better diagnosis, treatment and management for Patients Across the Continuum of Care

The Life Supporting Technologies group of the Technical University of Madrid (UPM) has developed an innovative solution that supports the integrated management of diabetes, in collaboration with the Technical University of Valencia and Medtronic Iberica. The solution was tested in a clinical exploratory study, in 4 clinical centres with 51 patients and 24 care professionals. It focuses on the improvement of diabetes disease management by providing patients and medical doctors with a technological platform to help them handle and analyze all information related to diabetes treatment, integrating it with patients' lifestyle data. The platform is arranged for interoperability and data transfer among different monitoring devices, based on shared semantics. Applications are running in Smartphone, Tablet and Home PC and are personalized to different profiles, supporting monitoring, education and HC communication functionalities. The added value and effectiveness of the integrated system as a whole is more performing than its beyond the use of its components separately, in terms of detection, delivery of care and adopted strategy.

Technology solution supported by the Technical University of Madrid

Technology solution

The solution provides a framework for diabetes disease management implemented in a technological platform. Treating professionals and patients are provided with applications running in multiple platforms and with multiple levels of interaction, depending on their profile. Population triage and stratification are implemented. American Diabetes Association guidelines have been transformed in a structured Professional Control Panel for patient monitoring, education, treatment prescription and follow-up activities. T1D and T2D patients are provided with tools to enable self-management, disease and healthy habits awareness. Few solutions are as much as comprehensive as the proposed one and the healthcare sector (the private, especially) is now demanding these tools.

Areas of application

- ICT applied to Health care and personalized care

D-House addresses the need of health practitioners to implement more effective care provision, and empower patients in being co-producers of their own care.

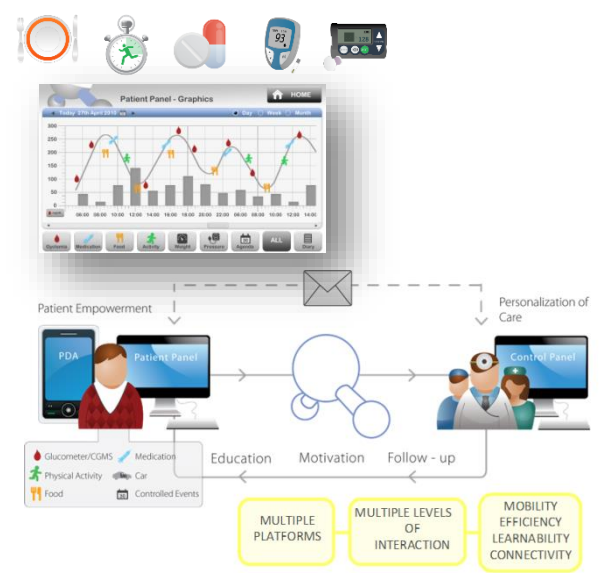

Market demands

Healthcare Sector (HC sector)

- Diabetes is one of the most important disease. By 2030, 550M people will suffer diabetes [WHO]
- The HC sector is evolving to new models were private-public collaborations, patient-centric care, prevention of onset and complication and health education are needed.
- Investments in HC technologies and consumer electronics including HC-like services have been exponentially growing
- Mobile health monitoring is one of the ten top applications in 2012 [Gartner]

“Health is a process not just an outcome: Diabetic patients must be followed along all the whole process and must recognize their role and that of the healthcare system in each stage”

Market potential

HC Sector

- 2.834€ is the average cost of T2D in Europe, representing 55% of HC cost [Code 2 study].
- 67M\$ overall cost in NHS Europe (IDF Atlas 2007) and 23M years of life lost per annum to disability and reduced QoL.
- Hospitalization is a major determinant for costs (T2ARDIS study) and usually is linked to complications
- Cost profile high at diagnosis and at complications onset.
- Loss of productivity may cost more than NHS direct costs [WHO, 2002].
- Mobile Health monitoring is one of the ten top applications in 2012 [Gartner].

Target

- 20-59yy (active population, technology friendly): 46% of diabetic people [Internet World Stats].
- 286M in EU (46%) mobile broadband subscribers, growing at a 7%-9% ratio each year [Distimo Report January 2011]

Diabetes Care devices market

- \$10.9 billion in 2009 with a Compounded Annual Growth Rate (CAGR) of 10% in period 2009–2016
- Forecast for year 2016: \$18 billion [GBI Research, January 2010].

Competitive advantages

- Completeness and at the same time the adaptability of the solutions
- Clear and assessed scientific background
- Independence from proprietary solutions in favor of interoperable developments
- Low costs SW application
- Validated in a exploratory study with 51 patients and 24 care professionals. Usability, User Acceptance and Satisfaction, Technical Feasibility have been assessed (more than satisfactory results). Clinical trends have been detected at a preliminary stage.
- Depending on the user and on level of the disease, we offer specific tools and solutions, encompassing education, monitoring and follow-up in “light” and “deep” modalities.
- Positive feedback was received when the paradigm and its application have been presented to potential clients and stakeholders.

References

- The project was evaluated with the maximum note (“Excellent”) by the expert panel nominated by the European Commission.
- Top level multidisciplinary collaboration in healthcare and technology: Medtronic, Healthcare Agency of Modena, Univeristy Hospital of Parma, Hospital Clínico de Madrid and Charles University Hospital of Prague.
- Solution will be further tested with other centres, among them Associação Protectora dos Diabéticos de Portugal.

Development stage

- Concept
- Industrial Prototype
- R & D
- Production
- Lab Prototype

Contact D-House

Giuseppe Fico
e: gfico@lst.tfo.upm.es
María Teresa Arredondo
e: mta@lst.tfo.upm.es
Life Supporting Technologies (UPM)
w: www.lst.tfo.upm.es

UPM contact

Innovation, Commercialization and
Entrepreneurship Area
Centre of Support for Technological Innovation
– UPM
e: innovacion.tecnologica@upm.es

MOOD MONITOR. Telemonitoring platform to assess mood disorders

Mobile app and wearable sensor to remotely assess mood status and empower patients with mood disorders

Life Supporting Technologies designed and developed a solution for the assessment and prediction of the mood status of persons with unipolar (e.g. major depression) and bipolar disorder. The system gathers subjective and objective data to estimate the evolution of the mood status; the patient is empowered by a set of tools that improve the therapeutic alliance with the health professional.

Technology solution supported by the Technical University of Madrid

Technology solution

The solution provides a tools to improve the therapy and the follow up of patients with unipolar and bipolar disorder. The end users use a Smartphone application (Android based) to record voice information (speech ratio, harmonies of the voice), report the mood status (questionnaires, mood scales), the medication intake and the daily habits (diary). The phone is connected with a wearable sensor that during the day monitors the level of energy and during the night the sleep quality. The concept provides support to the patient by providing a set of useful tools to communicate with the therapists, check the medication, mood charts and reminders. The Smartphone app also provides psycho education support (via personalized messages, educational content and goal settings support). A Web cloud service provides the access to this information to the health professionals and they remotely assess the mood status and prevent relapses or mood swings. The powerful visualization tools, the prediction tools and the alert systems enrich the user experience of the professionals to have a more clear understanding of patient situations. The solution is fully flexible and adaptable for several typologies of subjects: every module (e.g. medication tools, sleep monitoring, questionnaire) could be customized according to patient's condition.

"State of the art solution to assess mood disorder; a cost benefit solution to improve the therapy alliance, the disease management and the patient empowerment"



Areas of application

- **Health:** personalized health system for affective disorders; tele psychiatry; eHealth, mHealth.

Market demands

- The major mood disorders, unipolar (UP) depression and the bipolar (BP) disorders (both BP I and II expressions) have high lifetime prevalences and impact on individuals' ability to function. In 2012, the World Health Organization (WHO) ranked depression as the leading cause of mental health disability world-wide, affecting some 121 million people.
- Much of the economic burden of mental illness is not the cost of care, but the loss of income due to unemployment, expenses for social supports, and a range of indirect costs due to a chronic disability that begins early in life.
- Approximately 20.9 million American adults, or about 9.5 percent of the U.S. population age 18 and older in a given year, have a mood disorder [Archives of General Psychiatry, 2005].
- E-health services provide treatment and support to people with mental health disorders through telephone, mobile phone, computer and online applications, and can range from the provision of information, peer support services, virtual applications and games, through to real time interaction with trained clinicians. The treatment of mental health disorders through traditional techniques such as cognitive behavioral therapy has been shown to be effective in an online environment for high prevalence conditions.

"There is medical evidence of benefits of tele psychiatry and monitoring programs to promote and support mental wellbeing"

Market potential

Spanish health care

- Public funding of mental costs in this area are 3% less than the EU trends respect to the public cost of healthcare system. The innovation investments has been cut of the 8% in the 2013, but still there are opportunity of innovation in the hospitals where psychiatry department has active research and innovation programs for tele psychiatry services. The private healthcare system and the pharmaceutical industry could be another market to exploit.

Mobile application (mental wellness app)

- The exponential grow of the Smartphone technologies opens new opportunity to build a new sustainable model of health care. GSMA predicts that in future mobile solutions of health can have a market of 6.9TR \$ and save globally 400BN \$ in the OECD countries [GSMA Mobile economy 2013].
- During the last 2 years the application market offers a plenty of solutions (Mood tracker, Mood Panda etc) but none offers a solution that enrich the patient's information by using a wearable sensor.

Competitive advantages

- The system has been designed and tested involving real users.
- Small clinical trial (n=30) to measure the benefits of tele monitoring and remote mood assessment.
- Approval of ethical comité of Italy, Swiss and France
- High level of personalization of the telemonitoring routine.
- Personalization of the notifications / alarms for patient.
- Full data visualization on both side (patients and professionals).
- 8 years of experience in the design, development and validation of tele monitoring systems.

References

This research was partially founded by the EU founded project PSYCHE (IST 247777). The key partners that contribute to the research:

- Università di Pisa and Milano (Italia).
- Smartex (company that produces the wearable sensor).

Development stage

- Concept
- R & D
- Lab Prototype
- Industrial Prototype
- Production

Mood Monitor contact

Manuel Ottaviano
e: mottaviano@lst.tfo.upm.es
María Teresa Arredondo
e: mta@lst.tfo.upm.es
Life Supporting Technologies (UPM)
w: www.lst.tfo.upm.es

UPM contact

Innovation and Entrepreneurship Area
Centre of Support for Technological Innovation – UPM
e: innovacion.tecnologica@upm.es

TELMA. A new technology enhanced learning environment for Minimally Invasive Surgery (MIS)

Exploitation, enrichment and efficient management of surgical video allows the development of Telm@, a new MIS (minimally invasive surgery) learning environment based on web technologies

The solution presents a training and on-line learning environment based on laparoscopic video edition, knowledge management and collaborative work to improve the effectiveness and efficiency of surgeon's training process (both initial and ongoing). Telm@ supports the optimization of the trainee's learning curve, while providing surgeons ubiquitous access to didactic contents and methodologies and allowing them being more active and developing greater interactivity, a greater acquisition of knowledge and skills as well as a better use of the information sources available. The solution will reduce direct training costs and indirect health care costs associated with hospital stays and postoperative complications..

Technology solution supported by the Technical University of Madrid

Technology solution

The paradigm shift that is assuming the introduction of the MIS in clinical routine requires a change in the patterns of training new professionals.

Telm@ has created a new training strategy based on knowledge management, cooperative work and information and communication technologies in order to improve the effectiveness of the training process (initial and ongoing) of surgeons.

A new learning environment based on web technologies has been developed, providing a custom learning service to users and allowing them to create, share and reuse didactics contents in compliance with specific learning needs. For the above reasons, the use of the laparoscopic video is at the core of the didactic contents, adding them educational value by using an authoring tool tailored to the needs of surgeons.

The environment enhances the didactic value of surgical videos by editing them, giving the user a more interactive role in their initial or ongoing training and fostering collaboration between users with different surgical experience.

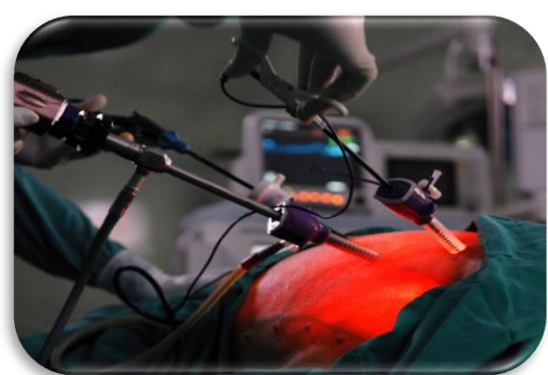

Areas of application

- **ICT applied to health:** cognitive skills training in MIS.

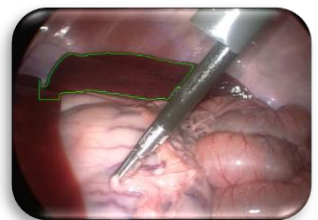

Market and social demands

Initial training

- Society demands greater investment in training and raising awareness of doctors and patients about the MIS benefits, which will increase its safety use.
- It is critical the development of training methodologies and the effective transfer of skills from the training environment to the doctors, in order to standardize the training and accreditation in MIS..
- Society demands effective training programs, which take into account the complex stages in the training of surgeons. Currently, such training processes for new surgeons are very demanding, extensive and costly.
- During the early stages of training, teaching should focus on the acquisition of knowledge outside the operating room, so that patient safety is not compromised due to medical errors resulting from a lack of preparation.
- Training programs with objective assessment that provide feedback to students on their progress in the learning curve are needed.
- Nowadays there is a video repository of surgeries that are not used for doctors training but have great educational potential.

Ongoing training

- Informal training for professionals who require little or no supervision.
- Fostering the exchange of knowledge among professionals for dissemination and training in new techniques of MIS.

Market potential

- In western countries, 50% of revenues are due to possible complications and postoperative convalescence. The arrival of MIS techniques, with any or short hospital stay reduces the social and economic costs. In USA, a 10% of the 15 million annual surgical procedures are performed with these techniques. In Europe it is estimated that in five years a 25% of all operations will be carried out by MIS.
- Outpatients' facilities and university hospitals: only in Spain, more than 150 university hospitals is a unique niche market for the proposed solution.
- Specialized training centers: large training centers (CCMIJU, IAVANTE), with hundreds of students a year, which offer in classroom and long distance learning
- Medical & Surgical Associations: could be interested in offer to its members the training programs.
- Surgeons

Competitive advantages

- Customized training: personalized learning content recommendation focused on training pathways linked to specific learning processes.
- Efficient management of knowledge: the solution monitors processes and interactions in the training environment, allowing the creation, capture, storage and distribution of information, turning it into reusable knowledge.
- Content management: content ingestion, automatic transcoding of new content to different qualities. Content retrieval based on medical thesaurus.
- Objective assessment of skills: the solution provides valid and reliable data about student performance automatically, instantly and objectively.
- Enrichment of surgical videos: the solution provides an authoring tool that allows the creation of educational content based on the editing and processing of surgical videos.

References

- Pilot experience carried out in a training center for surgeons and a hospital in the Spanish National Health Service. Other hospitals interested in the solution.
- The Bioengineering and Telemedicine research team of the Technical University of Madrid has an extensive collaborative experience with industry in R&D projects.
- Innovation commitment: The Bioengineering and Telemedicine research team has been involved in technology transfer through patents and the startup of new technology based companies.

Development stage

- Concept
- R&D
- Lab-Prototype
- Industrial Prototype
- Production

TELMA contact

Patricia Sánchez, Enrique J. Gómez
e: {psanchez, egomez}@gbt.tfo.upm.es

UPM contact

Innovation, Commercialization and
Entrepreneurship Area
Centre of Support for Technological Innovation –
UPM
e: innovacion.tecnologica@upm.es

AUDIOMC - Cochlear Microphonic Audiometry. The ultimate method for objective audiometric test

With only one test, gets the audiogram accurately and quickly without the cooperation of the patient and make an objective diagnosis in newborns and adults

Cochlear microphonics response are registered by two conventional surface electrodes placed behind the pinna (mastoid) and another one on the forehead. Data for each of the audiometric frequencies used in clinical procedures are obtained by a computer process reaches an identical audiometric profile obtained by conventional techniques. The system also provides a range of clinical information for the diagnosis of hearing disorders. All studies are performed without the cooperation of the patient, so it can be used even in premature newborns. The method provides fully reliable, as demonstrated in various hospitals in Madrid: Ramón y Cajal, La Paz, H. Clinico, among others. Given the extensive information obtained and the reliability of the system the results are superior to those obtained by other techniques, without increasing the cost of the studies. This solution has been developed by the Centre for Biomedical Technology at the Technical University of Madrid.

Technology solution supported by the Technical University of Madrid

Technology solution

Cochlear microphonics, are the response to sound stimulation of the auditory sensory receptors. Due to its small magnitude, they are difficult to register and for this reason, they are not currently used for diagnosis in clinical audiology.

Our technique completely eliminates external perturbations that could mask these biological signals, achieving more accurate results than those obtained with other techniques. Besides the usual audiogram, the differential intensity level (recruitment) and other parameters and diagnostic audiological research interest is determined.

"AudioMC make simple and reliable diagnosis of hearing disorders in neonates and patients with little or no responsiveness, which so far has not been achieved with other techniques"

Areas of application

- Health and ICT applied to health and personal care, specifically :
 - Unresponsive patients: newborn and older children, cognitive unpaired people, even animals or patients for which the subjective method is not useful.
 - Forensics: objective determination of hearing loss at work or caused by accidents or diseases.

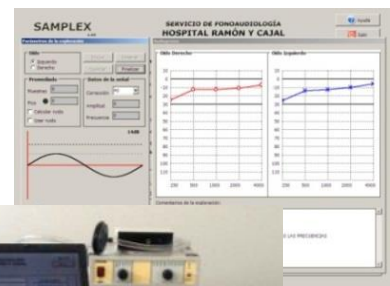

Market demands

▪ Children

- Even a mild or partial loss of hearing can affect a child's ability to speak and understand language. Hence, early diagnosis of hearing loss is crucial for the development of language, cognitive and psychosocial skills. However, until three or four years old, only objective screening methods are available with which it is not possible to obtain the required audiogram.

▪ Cognitive impaired & older people

- Studies suggest that elderly people with compromised hearing are at risk of developing cognitive deficits — problems with memory and thinking — sooner than those whose hearing is intact.

▪ Assurance Companies

- Sometimes doctors are under the obligation to emit reports about hearing damages due to illness or accidents, that generally will determine economic lendings or recongnition of discapacity. Objective test is needed independent of the opinion of employees, chiefs or governments.

Market potential

- More than 360 million people in the world have disabling hearing loss, according to the World Health Organization (WHO). One in three people over the age of 65 years (a total of 165 million people worldwide) have hearing loss.
- Hearing loss is strongly associated with aging, rapid growth in older population groups will cause the number of persons with hearing and balance impairments to increase markedly.
- In Spain, there are about one million people affected by hearing impairment (INE , 2000). Five out of every thousand newborn children have varying degrees of hearing loss (CODEPEH, 2000), and three of them will need prosthesis that should be prescribed as soon as possible.
- Without programs for early detection of congenital hearing loss, the average age of diagnosis is around three years old in the EU and USA, so these programs are needed to prevent future disturbances in language acquisition.
- The trend is to perform hearing screenings on all newborns allowing detection of infant hearing loss within the first month of life and diagnosis at 3 months to begin treatment as sooner as possible.

Competitive advantages

- The diagnosis is possible in cases for which now only screening are possible. So, therapeutic strategies like the use of audiphones are early possible, enlarging the market.
- The wide diagnostic spectrum of this objective method minimizes errors.
- The system contributes to the proper fitting of hearing aids.
- Simplifying diagnosis and providing more data, the technique could displace much of the studies performed today.
- Research on cochlear function acquires new perspectives on the possibility of extending the knowledge of sensory receptors.

“Our solution offers audiometric objective diagnosis in cases in which only screening is possible nowadays, in very few minutes and in a cost-effective way”

References

- The Centre for Biomedical Technology (CTB-UPM) brings together researchers from different disciplines on biomedical technologies in order address major challenges in Biomedicine and Health R&D
- Commitment to the development of biomedical technology and its transfer to the industry

Development stage

- Concept
- R & D
- Lab Prototype
- Industrial Prototype
- Production

AudioMC contact

José Javier Serrano Olmedo
Center for Biomedical Technology
e: josejavier.serrano@ctb.upm.es

UPM contact

Innovation, Commercialization and
Entrepreneurship Area
Centre of Support for Technological Innovation –
UPM
e: innovacion.tecnologica@upm.es

ARTIFICIAL PANCREAS. Advanced control of blood glucose

Automatic control of blood glucose levels in diabetes patient

The Technical University of Madrid, in collaboration with the Sabadell Hospital, has developed an algorithm that automatically calculates the insulin dose that should be administered to a continuous subcutaneous insulin infusion or 'insulin pump', in order to maintain healthy blood glucose levels. The control algorithm has been evaluated with a group of patients during the night and has managed to increase by 340% the time in normal glucose levels (80-110 mg/dl), therefore avoiding hypoglycemia during the night. The insulin pump manufacturers are potential customers of this algorithm which could be integrated easily into these devices.

Technology solution supported by the Technical University of Madrid

Technology solution

The control algorithm could be included directly into a continuous subcutaneous insulin infusion or to an external device capable of communicating in real time with the insulin pump and a continuous glucose sensor.

The algorithm is based on rules and forecasting techniques. Its operation is customized for each patient allowing maintain blood glucose levels within normal limits.

Its use will prevent low blood sugar (hypoglycemia) and high blood sugar (hyperglycemia), especially during night, which is when patients have more difficulty recognizing the symptoms.

"Automatic algorithm to maintain glucose levels within normal limits and minimize the risk of hypo-and hyperglycemia"

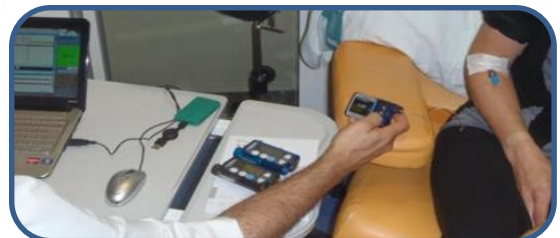
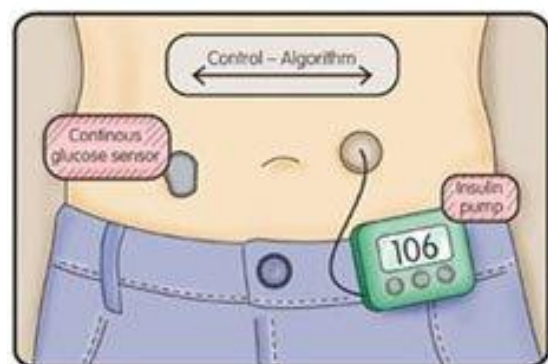

Areas of application

- **Health:** technology manufacturers for diabetes care (insulin pump manufacturers).

Market and social demands

- People with diabetes who use continuous insulin pumps generally have great freedom to adjust insulin to their routines and unexpected events, such as changes in mealtimes, food intake and quantities, physical exercise, disease states, stress, etc. all of which affect glucose levels.
- This fine adjustment of insulin requires knowing the blood glucose levels almost continuously but in a minimal invasive way. Nowadays, it is possible because there are commercial solutions which measure glucose every few minutes with a sensor implanted in the subcutaneous tissue.
- However, it is not easy for a patient to have a normal and quality life, if he must continually interpret his blood glucose profiles and make decisions about programming the insulin pump.
- The solution is the use of algorithms that can automatically control the insulin pump and to prevent hypoglycemic events, which is the greater risk in insulin treatment.
- Also it is important to avoid a continuous hyperglycemia over the years which could produce the loss of quality of life due to renal diseases, blindness, or amputations.

“The artificial pancreas can prevent and avoid hypoglycaemia and the occurrence of complications in the future due to poor metabolic control”

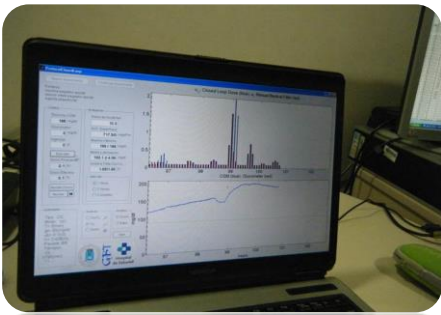

Market potential

- The global market for insulin pumps:
 - 1,600 million € per year, and
 - 9% annual growth.
- In the U.S.A., there are approximately 500,000 patients with insulin pump, which implies:
 - an initial outlay of about 4.000€,
 - replacing in a period of five years,
 - 6€ daily costs in consumables.
- In Spain there are currently about 6,250 pump users, which represents 4% of patients candidates to use compared to 37% of patients with pump reached in U.S.A.

Competitive advantages

- The control algorithm has been evaluated at the Sabadell Hospital with a group of patients during the night and has managed to increase by 340% the time in normal glucose levels (80-110 mg/dl), therefore avoiding hypoglycemia during the night.

References

- The research group GBT-Bioengineering and Telemedicine of the Technical University of Madrid has been working in the technologies diabetes field for 25 years, specifically in monitoring in consult and through mobile devices, decision support and control algorithms.
- In the artificial pancreas research line, the research group has collaborated with Sabadell Hospital and Sant Pau Hospital in Barcelona. The team has published several papers and has participated in a European Union project and two other projects funded by Fondo de Investigación Sanitaria:
 - INCA: Intelligent Control Assistant for Diabetes (IST2011-37632). 2003-2005
 - PARIS: Intelligent artificial pancreas (FIS PI042466). 2005-2008
 - A PRIORI: Predictive Analytics for insulin adjustment and optimization of systems in closed loop control using intelligent algorithms (FIS PS09/01318) 2010-2012.
- The research conclusions were presented at the Annual Congress of the Spanish Society of Diabetes and are under clinical journal publication.

Development stage

- Concept
- R & D
- Lab Prototype
- Industrial Prototype
- Production

Artificial Pancreas contact

M^a Elena Hernando
e: mariaelena.hernando@upm.es
w: <http://www.gbt.tfo.upm.es>

UPM contact

Innovation, Commercialization and Entrepreneurship Area
Centre of Support for Technological Innovation – UPM
e: innovacion.tecnologica@upm.es

GAMECARE. Lose weight the healthy way

Customized solution for obesity treatment designed to help you lose weight in a healthy way through ICT in such a simple way that it will even seem like a game

Life Supporting Technologies (LST) of the Polytechnic University of Madrid (UPM) together with healthcare professionals, has developed Gamecare, a virtual clinic based on intelligent systems that are able to monitor and control biological parameters and the user's diet information, with the aim of treating obesity. By applying innovative technologies, LST has achieved a low cost system that engages users. It also controls and supervises their activity steadily. Training modules and voice guidance have been validated with more than 30 users in a medical environment. The global market related to obesity in Spain is around 8% of the annual public health expenditure, therefore it is estimated that in 2013 the potential target market of Gamecare could grow up to 4,600 M €.

Technology solution supported by the Technical University of Madrid

Technological solution

The solution developed is an online clinic where the patient through virtual visits has the opportunity to follow the right method to treat obesity without having to commute.

This clinic is based on intelligent systems able to monitor and control both biological parameters and the patient's nutrition with the goal of losing weight.

By using different technologies the system can monitor the health of the patients and it is also able to engage them through games and achievements, as well as by means of social networks between doctors and patients. During physical training session, the doctor can control the patient in real time and he also has the opportunity to send supportive and motivational messages.

A new solution that helps to lose weight in a fun way while playing games, with continuous monitoring of the patient by professionals in a full immersion of social network with experts



Areas of application

- **ICT for health and wellness:** obesity; sport; healthy lifestyle; active aging.
- **Biotechnology:** smart textiles.



Market demands

- Obesity is considered the responsible for more than 3 million deaths per year worldwide. Obesity and overweight pose a major risk for developing chronic diseases, including type 2 diabetes, cardiovascular disease, hypertension and stroke, and certain forms of cancer. A total of 502 million people worldwide are obese and in the last 30 years the numbers have doubled; nowadays, more than 10% people are obese people. The World Health Organization (WHO) rates obesity as the pandemic of the 21st century.
- These 3 million obesity related deaths in 2010 is 3 times as much as the number of people who died due to malnutrition. The trend has been reversed, according to data collected over the past 20 years in the prestigious journal The Lancet report "Global Burden of Disease Study 2010".

"This is a global public health problem. Obesity is one of the four risk factors responsible for a high number of global premature deaths: 3 million deaths related to obesity have been recorded in 2010."

Market potential

- In the International Congress of Nutrition Programs and Physical Activity for the Treatment of Obesity (PRONAF) it has been affirmed that the treatment of obesity reaches a total 8% of health expenditure in Spain, this is the main result of a pioneering study on obesity held in Spain for the past five years. The causes of the high spending are: the low physical activity and the poor nutrition that affects Spanish citizens.
- According to the Ministry of Finance, public health expenditure expected in Spain for 2013 is 57.042 M €, this is a budget that exceeds the GDP of countries like Bolivia, Iraq, Uruguay and Luxembourg.
- In accordance to these sources the potential market of Gamecare is 4,600 M € per year only in the Spain public sector.
- Potential clients are: healthcare centers, both public and private clinics specializing in nutrition and weight loss, as well as sports and nutrition organizations or professionals of the healthy food industry.

Competitive advantages

- Pioneered development of the use of non-invasive textile sensors based on Continua Standards compliance interoperability with low-power technology Bluetooth 4.0: devices cost savings (50 € compared to 200 €).
- Training system and voice guidance validated with more than 30 users, getting an acceptance degree more than 95%.
- The use of games, personalised exercise with voice guidance and gamification in training sessions to support health care: users engagement.
- Realtime monitoring, management system of patients, creating custom rules (alerts, notifications...), feedback between doctors and users: continuous control and supervision.
- The use of social networks between doctors and users.

References

- Life Supporting Technologies has been working for over 10 years in the areas of health and wellness. It has also been partner in several European projects on nutrition and wellness such as: WeightInfo, PIPS, HeartCycle.
- AmIRTEM: a functional model for training of aerobic endurance for health improvement. IEEE transactions on bio-medical engineering, August 2012 DOI: 10.1109/TBME.2012.2207953
- Aml System for Functional Assessment of Aerobic Endurance EMBC'11: 1st IEEE Unconference on Wearable & Ubiquitous Technology for Health & Wellness, Boston, August 30, 2011

Development stage

- Concept
- R & D
- Lab Prototype
- Industrial Prototype
- Production

GameCare contact

MT Arredondo, Eugenio Gaeta, Gloria Cea
Life Supporting Technologies (LST) - UPM
e: {mta, eugenio.gaeta, gcea}@lst.tfo.upm.es

UPM contact

Innovation, Commercialization and
Entrepreneurship Area
Centre of Support for Technological Innovation –
UPM
e: innovacion.tecnologica@upm.es

BIOLASERSPORTS. Improved sports performance at the highest level

System for biomechanical analysis of the athlete: real-time information to optimize competitive performance

Researchers from the Faculty of Sciences for Physical Activity and Sport of the Technical University of Madrid, in collaboration with the University Pablo Olavide of Seville, develops Biolasersports, a complete system of recording, analysis and interpretation of biomechanical data of the athlete in motion. Provides real-time critical information to the coach, able to optimize the performance in sports where technical efficiency depends on the velocity, such as football and athletics. Another important characteristic is its reliability in data collection, because the system is capable to integrate the movement of the athlete through a mobile laser system. In sports environments increasingly competitive, Biolasersports is an innovative breakthrough in the application of the latest technologies to the sport.

Technology solution supported by the Technical University of Madrid

Technology solution

Biolasersports is a kinematic analysis system of competitions and sports training in real time.

Based on laser technology, a mobile platform on mechanical rails measures the instantaneous speed of an athlete along their displacement.

The biomechanical data captured are processed by a software, which record, analyze and perform an assessment of motor skills and sports technique (applied to distance traveled, speed and acceleration).

This accurate information, offered in real time, is very valuable to the coach, who will be able to use biomechanics science as a tool to improve sport performance.

Areas of application

- **ICT applied to health**, physical and sports science, sports biomechanics.

"Biolasersports provides key biomechanic data about the athletes and their movement during the race, for improving their performance"



Market demands

- The Sports Biomechanics is recognized as a key for improving athlete performance. Specifically, the study of the motion of bodies with respect to the speed of movement is critical for a big number of competitions.
- It is needed techniques of sports performance analysis in real time: immediate feedback to the trainer and athlete for effective decision making.
- Nowadays, laser systems are generally adapted and used for measuring the speed of movement, compared to classical techniques such as photoelectric cells or the use of video.
- Current solutions using laser technology to track the athlete require specific conditions to obtain reliable data which are not met in practice: rectilinear movements or without interposition of other elements during the measurement (interpositions probability occurs up to 40% of the measurements real).
- It is needed mobile measurement systems, adapted to the natural motion of athletes without interfering it.

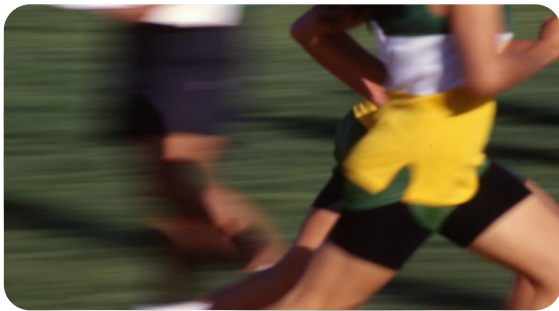

Market potential

- In Spain, sports industry is about 2% to GDP (9,000 million € a year of income), with a growth rate similar to the most dynamic sectors, such as new technologies. [Sports Council - Spain]
- In Europe, in 2010, this industry generated revenues of 63 billion € compared to € 213 billion worldwide, a decline of 2% from the previous year. [NPD Group]
- The main European markets in the sports industry are Germany (11%) and France (9%). Spain is the fifth (4.7%). [NPD Group]
- Potential customers for Biolaserports are the sports federations. Only in Spain there are 64 registered, among which those of athletics, basketball, handball and gymnastics have an annual budget over 5 million €. The football federation has a budget of € 86 million.

Competitive advantages

- Industrial prototype done, optimization is needed.
- Technological support to the coach for improving effectively the performance of athletes.
- On time biomechanical results: without the data digitization needed in classic techniques of photogrammetry which are time-consuming.
- Application to any sport in which the race is critical to the performance (football, basketball, athletics, cycling, handball, gymnastics ...), both in competition and training.
- No affect the natural motion of athletes thanks to laser technology
- Software tools included for the interpretation of biomechanical data collected and its assessment: reference variables, historical ...
- Portable, lightweight and easy to assemble: adaptation to any terrain or sports court.

IPR

- Patent granted in Spain [ES2331170]

Development stage

- Concept
- R & D
- Lab Prototype
- Industrial Prototype
- Production

Biolasersports contact

Amalia Ferro Sánchez
e: amelia.ferro@upm.es

UPM contact

Innovation, Commercialization and
Entrepreneurship Area
Centre of Support for Technological Innovation
– UPM
e: innovacion.tecnologica@upm.es

LST-BOX. A box full of services for better living

LST-Box helps the older people to control home automation devices, monitor their health and stay in touch with family, caregivers and friends through social networks, in a customized and intuitive way

Facilitating daily living of the older people through self care of health and diet, control of household devices and frequent communication with family members, caregivers and friends through social networks are the main functions of the LST-Box. This "service box", developed by Life Supporting Technologies group, is an ICT tool that connects various sensors and actuators to provide its functionality, and it can be accessed through television, mobile phone or computer both from within and outside the home. All this in a personalized way for the user according to his needs and preferences.

Technology solution supported by the Technical University of Madrid

Technology solution

The LST-Box solution offers a system composed of hardware with internet connection and Bluetooth which integrates three services specifically designed to facilitate daily life of the older people:

- KNX domotic control (includes security alerts),
 - management of social networks (Facebook and Twitter) and self monitoring of health care, to track daily blood pressure, weight, medication and diet via Bluetooth connection to a blood pressure cuff and a scale.
- These data can be shared with the primary care physician via email. LST-Box can be accessed through the television, computer or smartphone both within and outside the home. Services are offered in a personalized way, adapted to the needs and preferences of the user, in terms of its contents presentation and the way he interacts with them.

Commercial application sectors

- **Health:** ICT applied to health and personal care; ICT applied to independent living and e-inclusion.

"LST Box offers an independent living support system, integrating home automation devices with health sensors and social networks"



(example of commercial set-top box)

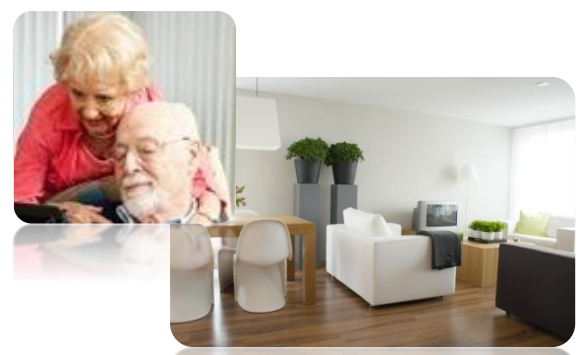

Market demands

- Need for improved technology approach to older people [Seniorwatch, 2008]. ICT solutions can prolong independent living for the older people and extend the time they remain active and safe in their everyday environment.
- The process of aging is leading to an increasing number of older people (aged 65 years or over) with various health problems such as hypertension, obesity, dementia, etc.. It is necessary that health and welfare systems are adapted to be more friendly to older people, through active promotion of health and self-care.
- The main fears of getting older are living with physical limitations (worldwide, more than 46% of people over 60 have a disability), having to depend on other people (the dependence increases with age) and feeling alone [INE].
- Loneliness is a common problem among the older people, and the fact of living alone is not always an indicator of loneliness. For senior citizens, social support is very important, especially when something bad happens.

“The main fears of getting older are: living with physical limitations, depending on others and feeling of loneliness”

“...the solution is being tested on a pilot with 7.000 users in several European regions...”

Market potential

- At global scale, every second 2 people turn 60, which means that the annual total is almost 58 million people that turn 60. In 2012, 810 million people were 60 or older. It is estimated that the proportion will be 1 over 5 people in 2050. [Aging in the XXI Century, HelpAge Internacional].
- In Spain, 85% of older people have access to ICT solutions, 86,6% of people between 55 and 64 years old and almost 80% of people over 65 use mobile devices. This is a great market potential for assistive technologies[CENTAC].
- Regarding expenditure, people with disabilities invest, on average, 25% more in ICT solutions than the rest of the population, which is equivalent to more than 2.800 annual Euros– 9% of average expenditure per family unit. [EDAD].

Competitive advantages

- Multiplatform: access to services through various devices (TV, mobile, tablet), vs. dedicated devices.
- Modularity: additional services and sensors can be installed, vs. closed, not modular systems.
- Configurable and personalizable solution, according to the user’s needs and preferences, providing high usability levels. Especially focused on older people (contents, user interface).
- Reduction of health and welfare services expenditure, thanks to the support on self-care and health status self-management (the system improves the accessibility at home and increases the older’s people autonomy): 80% of public health resources are assigned to chronic diseases management and it is estimated that managing these conditions through ICT solutions could help reduce around 15-30% of the expenditure. [CENTAC].
- The solution is being tested on a pilot with 7.000 users in several European regions.

References

- Multidisciplinary research team (Life Supporting Technologies), with more than 10 years experience on solutions for health and wellbeing, and partner in cutting-edge projects in the area.
- Integrated with the Smart House Living Lab infrastructure, member of ENoLL (European network of Living Labs).

Development stage

- Concept
- R&D
- Lab-prototype
- Industrial prototype
- Production

LST-Box contact

Juan Bta. Montalvá, Viveca Jiménez, María Teresa Arredondo, María Fernanda Cabrera
e: {jmontalva, vjimenez, mta, chiqui}@lst.tfo.upm.es
Life Supporting Technologies
w: www.lst.tfo.upm.es

UPM contact

Innovation, Commercialization and Entrepreneurship Area
Centre of Support for Technological Innovation - UPM
e: innovacion.tecnologica@upm.es

CARDIOREHAB. A personalized system for cardiac rehabilitation at home

Custom system for home cardiac rehabilitation for coronary heart disease patients

Life Supporting Technologies Group of the Technical University of Madrid (UPM), in collaboration with European partners, has developed a customized solution for home cardiac rehabilitation for patients with coronary heart disease who have suffered an acute cardiac event. The solution includes an application developed on a mobile device, a wearable sensor and a t-shirt, which monitors patients in real time while performing exercises previously prescribed by their doctor. Furthermore, the system also includes an application on a tablet that the patient can use from home to check their results and progress, receive information about his rehabilitation status, and access a full program of education and motivation. CardioRehab is complemented with an application for the medical professionals, in which data are collected during the exercise sessions of patients for analysis and monitoring. The solution has been validated by patients and healthcare professionals in a randomized trial, and has been used for 60 patients in three different European countries.

Technology solution supported by the Technical University of Madrid

Technology solution

CardioRehab offers a technological solution for cardiac rehabilitation of patients with coronary heart disease who have suffered an acute cardiac event (e.g., myocardial infarction or coronary surgery). It includes a rehabilitation program that addresses not only physical exercise but also other aspects such as education and patient's motivation.

The solution consists of an application on a mobile device together with a wearable sensor and a t-shirt, which monitors patients in real time while performing physical exercise according to a plan of care prescribed by the doctor. A second application on a tablet offers patients continuous feedback on progress and evolution, as well as an innovative educational and motivational strategy focused on formal aspects of their disease, helping them deal with risk factors, and motivate them to follow a healthy style life.

CardioRehab also includes an application for medical professionals, in which data are collected from different patients for analysis and monitoring.

"Personalized system for cardiac rehabilitation at home based on ICT which includes a complete physical exercise program along with an innovative education and motivation strategy"

Areas of application

- **Health:** e-health (cardiology, cardiac rehabilitation, management of coronary heart disease).

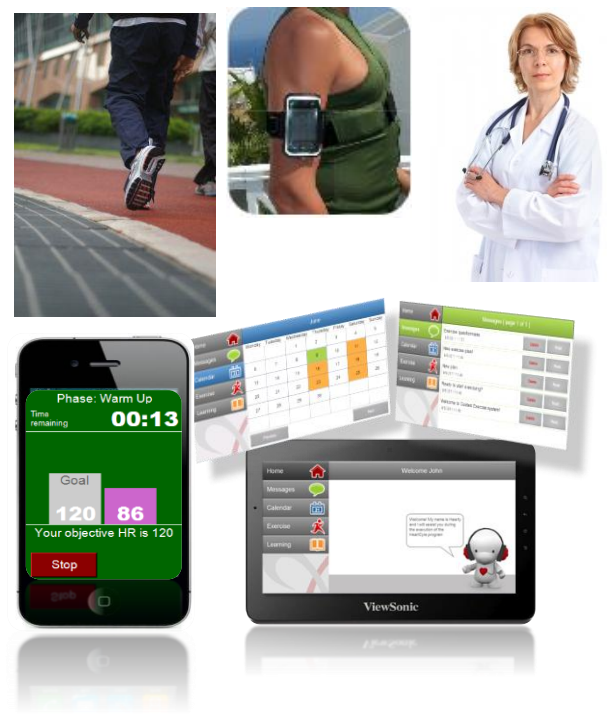

Market demands

- Coronary diseases is estimated to cost the EU economy almost €60.000 million a year, 31% is due to cardiovascular disease (CVD) [European Cardiovascular Disease Statistics 2012].
- Of the total cost of CVD in the EU, around 33% is due to health care costs, 29% due to productivity losses and 38% due to the informal care of people with CVD informales [European Cardiovascular Disease Statistics 2012].
- Several studies have shown that cardiac rehabilitation is beneficial for patients who have suffered a cardiac event.
- Cardiac rehabilitation reduces the likelihood of early death by 20% -25% and the risk of heart attack by 28%.

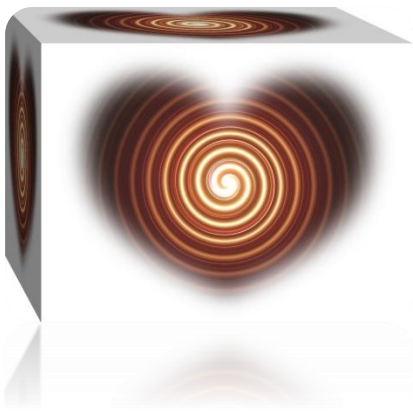

Market potential

- In Europe:
 - Fewer than half of eligible cardiovascular patients benefit from Cardiac Rehabilitation in most European countries [European Cardiac Rehabilitation Inventory Survey].
 - Deficits include absent or inadequate legislation, funding, professional guidelines and information systems in many countries [European Cardiac Rehabilitation Inventory Survey].
- In Spain:
 - Every year, there is an average of 55.582 acute myocardial infarction and each of them has a unit cost of 14,069 Euros [Spanish Journal of Cardiology, 2012].
 - Cardiac Rehabilitation units have capacity to serve only 3% of the infarcted [SEC 2012].
 - Cardiac rehabilitation programs are recommended only 0.6% of high-risk patients who need care. Only receive rehabilitation 0.2% [SEC 2012].

Competitive advantages

- CardioRehab is the first cardiac rehabilitation program based on ICT which combines aspects such as physical rehabilitation, and education and motivation strategies based on internationally recognized programs (such as the Heart Manual, NHS Lothian, United Kingdom).
- It has been validated with patients and healthcare professionals in a randomized trial with 120 patients in three European countries (Spain, Germany and the UK).

References

- Multidisciplinary researcher group specialized on technologies for the health and well-being. More than 10 years collaborating with European partners of reference.

“The system has been tested and its functionality has been validated by 120 patients and healthcare professionals in Spain, Germany and the UK”

“CardioRehab provides a low cost solution for personalized cardiac rehabilitation at home”

Development stage

- Concept
- R & D
- Lab Prototype
- Industrial Prototype
- Production

CardioRehab contact

Cecilia Vera Muñoz; María Teresa Arredondo
e: {cvera, mta} @lst.tfo.upm.es
Life Supporting Technologies (UPM)
w: www.lst.tfo.upm.es

UPM contact

Innovation, Commercialization and
Entrepreneurship Area
Centre of Support for Technological Innovation –
UPM
e: innovacion.tecnologica@upm.es

GPR DEVICE. Because you and your health are the first

Thrombectomy device for removal of arterial blockages through aspiration

A stroke disease occurs when blood flow of part of the brain stops, in case of more than a few seconds, the brain can not get blood and oxygen, causing permanent damage. According to WHO, more than 17M people die from cerebrovascular disease. Only in the U.S. affects more than 700000 Americans each year, causing 150000 deaths and remains the leading cause of disability in adults and the third leading cause of death. In Spain, strokes are the leading cause of death in women, one of the neurological diseases of greater social impact, with 130.000 new cases each year.

Ischemic stroke occurs when a blood vessel supplying blood to the brain is blocked by a blood clot. Treatments for such accidents can be divided in chemical and mechanical thrombectomy devices. The decision to develop a new device which allows effectively eliminate the presence of these clots, lies in the high percentage of population affected and the various risks found when performing an analysis of the situation today.

Technology solution supported by the Technical University of Madrid

Technology solution

The purposes of any mechanical thrombectomy device can be summarized in effecting the removal of the clot formed inside of the artery and restoring blood flow from the artery. From recent years, numerous devices have been developed, many of them operating at the periphery of the vascular system, however, relatively few have been used in the cerebral vasculature. One of the main problems of these devices is that they can produce embolisms or breaks downstream of the arterial walls due to their moving parts.

As a result, there is a need to design a device based on aspiration, without moving parts, with a simple design, and that can act as an effective remover of blood clots without causing possible embolisms due to the breakage of the blood clot.

Areas of application

- Health

"Simple, practical and effective"

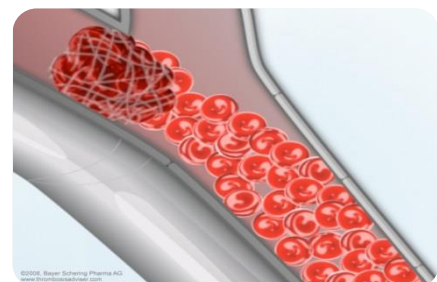
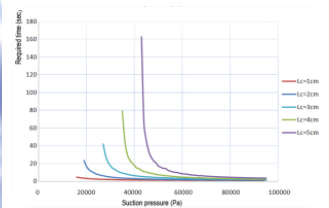
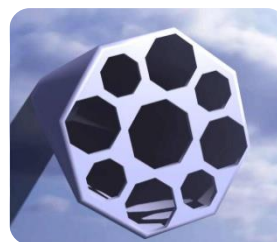

Market demands

- In recent years it has grown the number of solutions developed for the purpose stated herein - more than hundred - not existing a common denominator to all of them. Some devices rely on clot perforation; other, however are based on the trapping of the blood clot through the use of deformable elements, called stents.
- After analysis of different commercial solutions have been seen different turning points and the need to develop a product that involves less risk to the patient, shorter, both preparation and use, and lower production costs.
- If we analyze almost all existing devices, we observe there is a great possibility of creating disintegrations of the main blood clot, which could cause future problems in smaller arteries. Moreover, the existence of different moving parts make the manufacturing cost be high (300 ÷ 3000 €/unit) and that the risk involved in handling or operating methodology be inherent.
- The correct optimization would be carried out by means of simulation techniques and would require greater engagement between medical and engineers to, on the one hand, correctly analyze the formation process of the blood clot and, secondly, develop the device.



Market potential

- Given the limitations in the use of the device described here, the existing market potential was estimated from three main areas:
 - Large percentage of population affected;
 - Sector 'Health', with continuing need for finding new solutions and means to do so; y
 - Problems found in the competence.
- This potential can be seen from the large number of thrombectomy devices developed in recent years, which shows the concern in the sector, the continuing need for innovation and the growing interest of the different laboratories.

Competitive advantages

- Devices such as SOLITAIRE or MERCI, despite its proven success, contain mechanical parts based on the use of stents, resulting in the possible rupture of the artery or the blood clot.
- The extraction device recently designed in UK and called 'GP' contemplates idealized features here, but nevertheless has been seen after numerous analysis how the existence of a return on the suction or a constant distance to the clot makes it unavailable for use in some cases. The fact of no moving parts provides a starting point for the development of a new device that involves fewer risks and higher effectiveness.
- It have been developed simulation models; it remains to make a more realistic sizing of these prototypes and laboratory verification.

References

- Several articles published in international journals and conferences, having received an invitation from a prestigious American publishing house for editing a book to analyze thoroughly the problems encountered.

Development stage

- Concept
- R & D
- Lab Prototype
- Industrial Prototype
- Production

GPR contact

Gregorio Romero
CITEF. Railway Technologies Investigation Center
e: gregorio.romero@upm.es
w: www.citef.industriales.upm.es

UPM contact

Innovation, Commercialization and
Entrepreneurship Area
Centre of Support for Technological Innovation –
UPM
e: innovacion.tecnologica@upm.es

HF MANAGEMENT. System of monitoring and management of heart failure

Custom system for monitoring and management of heart failure at home

Life Supporting Technologies Group of the Technical University of Madrid (UPM), in collaboration with European partners, has developed a customized solution for home monitoring and management of chronic heart failure patients. The solution includes an application for patients based on the use of various sensors and questionnaires that allow monitor their health daily. The data collected by the application are sent to the medical professional, which through another application can perform an analysis and monitoring progress of the patients. HF Management also integrates an innovative strategy for education and motivation of patients. The solution has been validated by patients and healthcare professionals in a clinical observational study of 104 patients in two European countries for one year.

Technology solution supported by the Technical University of Madrid

Technology solution

Heart Failure (HF) Management offers a technological solution for monitoring and management of patients suffering from chronic heart failure.

The solution includes an application for the patients, developed on a Tablet, which with the help of several sensors can monitor their health daily. The application also offers assistance to patients with daily routines needed in the care of their disease (e.g., medication management, questionnaires, etc.) and also includes a full program of education and motivation.

All collected data are sent daily to the medical professional, who has an ICT application that allows them analyze, identify potential problems, adjust the medication and treatment of patients more effectively.

"Personalized system for monitoring and management of Heart Failure"



Areas of application

- Health: e-health (cardiology, heart failure management)

Market demands

- The cost of treating heart failure represents 1 - 2% of total medical expenses in Europe, two-thirds of this cost is due to patients hospitalizations [World Journal of Cardiology, 2012].
- Approximately 50% of patients suffering from heart failure must be re-hospitalized within 6 months from the previous hospital stay [World Journal of Cardiology 2012].
- Tools are needed that allow a closer monitoring of these patients, daily monitoring included, support with routines and regular information.

“HF Management allows personalized and effective monitoring of heart failure patients, detect decompensation, and reduce hospitalizations and associated costs”



Market potential

- Over 26 million people suffer from heart failure around the world and over 3.6 million people are newly diagnosed with heart failure every year [European Heart Failure Association].
- In Europe it is estimated that about 15 million people suffer from heart failure [World Journal of Cardiology 2012].
- In Spain:
 - Heart failure is the leading cause of hospitalization in patients over 65 years old [Revista Española de Cardiología 2012].
 - The leading cause to cardiac decompensation is poor compliance that occurs in 15-65% of cases [Revista Española de Cardiología 2012].

Competitive advantages

- Integration of monitoring tools along with educational and motivational strategies based on internationally recognized programs.
- The monitoring system has been validated with patients and medical professionals in a clinical observational study with 104 patients for one year in two European countries (Spain and Germany).

References

- Multidisciplinary research group specialized on technologies for the health and well-being. More than 10 years collaborating with European partners of reference.

“Validation with patients and healthcare professionals in a clinical observational study with 104 patients during one year in Spain and Germany”

Development stage

- Concept
- R & D
- Lab Prototype
- Industrial Prototype
- Production

HF Management contact

Cecilia Vera Muñoz; María Teresa Arredondo
e: {cvera, mta} @lst.tfo.upm.es
Life Supporting Technologies (UPM)
w: www.lst.tfo.upm.es

UPM contact

Innovation, Commercialization and
Entrepreneurship Area
Centre of Support for Technological Innovation –
UPM
e: innovacion.tecnologica@upm.es

PARKINSON-MONITOR. Monitoring and follow-up of patients with Parkinson's disease and Parkinsonism

Wearable sensors and WEB platform enables remote monitoring, evaluation and daily monitoring of patients with Parkinson's disease.

Life Supporting Technologies group, belonging to the Universidad Politécnica de Madrid, has developed an innovative solution based on low cost wearable sensors that allow remote monitoring of patients with Parkinson's disease (PD). The system can detect and quantify the major motor symptoms of PD. The solution is built on an ICT platform, the processing is done in the cloud while doctors can view and manage all the information related to their patients using a web application. The system has been tested in three different European hospitals showing an accuracy of over 80% to quantify the severity of various motor symptoms. The system has been designed and validated with the feedback provided by both physicians and patients.

Technology solution supported by the Technical University of Madrid

Technology solution

The developed solution consist of a Web platform that automatically receives and processes daily motion information of patient with PD, gathered from a series of wearable sensors. The Web portal also includes a professional portal that allow medical professional to the remote follow-up of their associated patients.

This system aims to provide a tool for the objective and efficient monitor the status of patients with Parkinson's disease for the healthcare professionals.

Thanks to the continuous monitoring and the objective evaluation given by the system, physicians have a detailed information in order to improve the diagnose and personalize treatment for their patients.

Areas of application

- **Health:** e-health; professional tools for monitoring and management of patients with Parkinson's disease and parkinsonism.

"The first intelligent ICT solution that enables remote monitoring, continuous evaluation and monitoring of Parkinson's Disease patients"

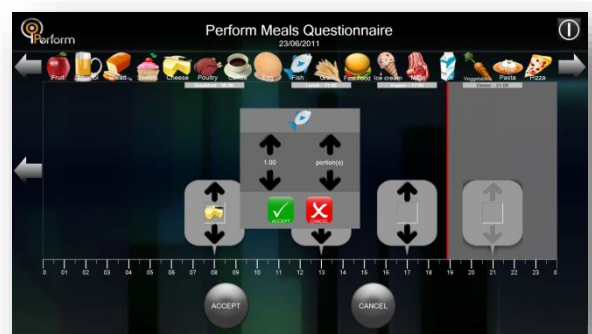

Market demands

- Parkinson's disease is the second most prevalent disease. PD affects around 7 million people worldwide. It is closely related with ageing and consequently its impact grows exponentially with the age.
- Due to the link between PD and age the incidence of the disease is specially remarkable on the most aged countries, such as US and the EU. Parkinson's disease contributes to 0.1% of the global disease burden and 0.6% burden on the EU [World Health Report - 2001, OMS].
- The healthcare system required novel and innovative tools to deal efficiently with chronic disease patients and specifically with Parkinson's disease patients. These new tools should reduce the costs and provide an efficient communication tool between patients and healthcare professionals.
- Pharma industry is also looking for monitoring tools able to provide a continuous monitoring and objective measure of the patient status in order to reduce cost in drugs trials

"This solution won the pHealth Innovation Award 2010 under the 7th International Conference on Wearable Micro and Nano Technologies for Personalised Health"

Market potential

▪ Health Sector

- Chronic diseases cause more than the 80% of the primary care consultation and more than the 60% of hospital admission. It is estimated that 72% of health spending in public sector is due to chronic illness.
- It is estimated that the costs of patients with multiple chronic disease, are multiplied by six respect to patients with an unique chronic disease. [PwC]
- The increasing demand for real-time data on a large number of applications is increasing the development of wearable technologies. In 2016 Wearable technologies represent a business opportunity for a minimum of \$ 6 billion [World Market for Wearable Technology - A Quantitative Market Assessment - 2012, IMS Research].

Competitive advantages

- Allows the objective and quantitative monitoring and evaluation of Parkinson's patients .
- The continuous monitoring and the evaluation allows the treatment's personalisation
- The medical tool has been developed following the indications and the requirements suggested by the doctors of three different European hospitals.
- The system has been developed following an iterative process to analyze and improve the features according to the feedback suggested by doctors.

References

- Tested with more than 100 patients, accuracy greater than 80% in quantifying the severity of motor symptoms
- Research group with over 8 years of experience in the design, development and validation of tele-monitoring systems

Development stage

- Concept
- R & D
- Lab Prototype
- Industrial Prototype
- Production

Parkinson-Monitor contact

María Teresa Arredondo
Life Supporting Technologies - UPM
e: mta@lst.tfo.upm.es
w: <http://www.lst.tfo.upm.es>

UPM contact

Innovation, Commercialization and
Entrepreneurship Area
Centre of Support for Technological Innovation
– UPM
e: innovacion.tecnologica@upm.es

DALEMOV. Cognitive stimulation therapy oriented to people with Parkinson's

Cognitive stimulation supervised mobile platform for people with Parkinson Disease

DaleMov is a solution oriented to people with cognitive disease due to Parkinson's. They can carry out their rehabilitation therapies in a remote way under the supervision of their therapists. Therapy is personalized for each patient according his/her needs. In addition, therapists can add new exercises designed by them in a easy way. This solution is formed by tablet application used by patient and a web access used by therapists. DaleMov allows people who can not attend periodically to any association can benefit from this kind of remote therapies.

Prototype has been designed under the advising of expert therapists. The platform have been tested by several patients with highly satisfactory results. The research work has been funded by Vodafone Spain Foundation.

Technology solution supported by the Technical University of Madrid

Technology solution

DaleMov is a mobile platform oriented to people with mild of moderate cognitive impairment due to Parkinson, who can carry out their therapies under their therapists' supervision in a remote way.

DaleMov platform works in a client-server model. Patient performs his/her cognitive therapy and therapist personalizes his/her therapy according his/her results, giving a positive evaluation which can be consulted through patient's device.

Patient application is based on Android for tablet with Internet connection. Therapist monitors patient's results through a web connection, adapting the therapy. In addition, he/she can add new exercise in an easy and intuitive way.

"New solution oriented to people with Parkinson's carry out remote personalized cognitive stimulation therapies according to their needs, everywhere and at any time".



DaleMov

Areas of application

- **ICT applied to health and personal care:** cognitive stimulation; e-health, tele-rehabilitation; active ageing; independent living.

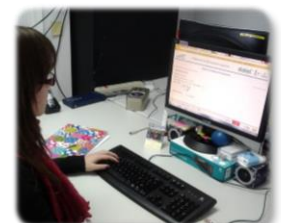

Market demands

▪ ICT applied to health and personal care

- Several researches have highlighted the benefits of cognitive stimulation therapies aimed at people with cognitive deficits, such as the delay in deterioration process and improving their quality of life. [Orrell, M., 2005]
- People with Parkinson disease carry out cognitive stimulation therapies both prevention techniques and for the maintenance of their abilities for as long as possible.
- Many of these people can not benefit of these kind of therapies due to their mobility problems or for living in a rural areas, far away of any association.
- Nowadays, there are solutions in the market used by PC. People with Parkinson's have a lot of problems when they using it because of their motor disease associated to their illness. Due to that, using a tablet may destroy this digital divide [European Parkinson's Disease Association].

“Cognitive stimulation may delay cognitive impairment due to Parkinson disease, improving the quality of life of these patients”

Market potential

▪ People with Parkinson disease

- Parkinson disease affects 120,000 people in Spain, taking them 65% of cognitive impairment associated to this disease. 30% of diagnosed people are under 65 years old. [Madrid Parkinson Association]
- There are 6.3 million people on the world who suffer this disease, with a trend that can reach up to 9.3 million in 2030. [European Parkinson's Disease Association]

▪ People with other cognitive diseases

- In Spain, there are about 600.000 people with dementia and close to 400.000 who suffer Alzheimer. [Center for Biomedical Research in Neurodegenerative Diseases, Spain]

Competitive advantages

- DaleMov has been designed taking in account the needs of affected group (patients and therapists), who have been involved in all the process of design and evaluation.
- It has carried out an evaluation with 30 patients in Spanish Parkinson associations and 2 patients at home, with highly satisfactory results.
- Unlike other solutions on the market, DaleMov allows continuous monitoring of patients by their therapists and management therapies according to the needs of the patient.
- Because of the versatility of the developed platform, it could be adapted easily to the needs of other groups that present cognitive impairment, such as Alzheimer's or mild cognitive impairment.

References

- DaleMov has been funded by Vodafone Spain Foundation and it has been supported by Spanish Parkinson Federation.
- First study over interactive digital television (project funded by Elderly and Social Services Institute, Spain).

IPR

- Software registration

Development stage

- Concept
- R & D
- Lab Prototype
- Industrial Prototype
- Production

DaleMov contact

Miguel A. Valero Duboy
e: mavalero@diatel.upm.es
Telematics Systems for Information and Knowledge Society Research Group (T>SIC – UPM)

UPM contact

Innovation, Commercialization and Entrepreneurship Area
Centre of Support for Technological Innovation – UPM
e: innovacion.tecnologica@upm.es

HEALTH-mate. Healthy Lifestyle Manager

Ubiquitous lifestyle management system to empower their users to manage, in a multidimensional integrated way, the daily lifestyle choices to tackle selected wellness/care objectives of their patients and customers

Researchers from the Center for Biomedical Technology (CTB) of the Technical University of Madrid and Colorado Center for Health & Wellness of the University of Colorado Anschutz Medical Campus Denver USA, has developed HEALTH-mate, a comprehensive platform designed to manage personal health promotion, prevention and care plans under the shift to risk based payment methods. The solution enable customers to: 1) configure lifestyle objectives, 2) be aware of the overall wellness status of the users, 3) integrate diverse biosensing data coming from the multiple sensors/apps of smartphones and wearable devices so that can be manageable for the creation of personal health prevention plans and 4) seamlessly overcome personal barriers. By means of providing the information, motivation and abilities enhanced in ways not sufficiently well integrated within daily activities so far, to boost their positive perception and their satisfaction from healthy daily choices.

Technology solution supported by the Center for Biomedical Technology of the Technical University of Madrid and Colorado Center for Health & Wellness of the University of Colorado Anschutz Medical Campus Denver

Technology solution

Health-mate is an integrated management platform consisting in a cloud-platform (four basic engines) and several end-user personal devices.

The cloud-platform include: a wellness assessment (providing an objective measurement of people's overall wellness status); a barrier assessment (detecting obstacles preventing people from fully developing healthy lifestyles); a wellness program manager (providing actions and personalized wellness tracks to reach objectives); a profiling engine (for discovering new key knowledge about users); a data transformation engine (to get data from any device).

End-user personal devices consist of smartphone-based Body Area Networks (BAN), involving all their built-in sensors and features, together with any possible external sensor attached to them.

"HEALTH-mate is a comprehensive platform designed to manage personal health promotion, prevention and care plans"

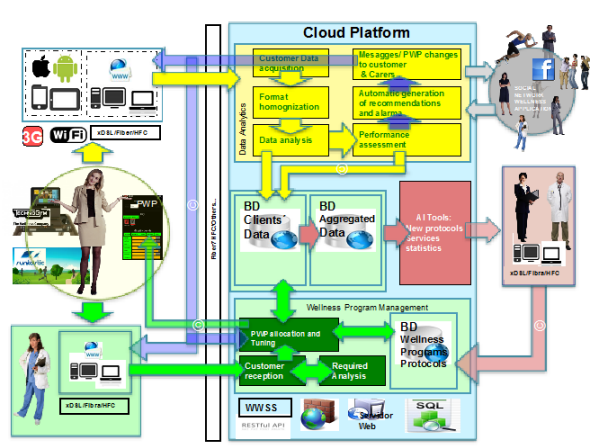

Health-mate cloud-platform

Areas of application

- ICT applied to health and personal care: organization interested to implement stable and long lasting lifestyle changes required by the wellness market (Fitness centers, health, wellness research institutions, health insurance providers, health administrations).

Market demands

▪ TICs & Mobile Apps

- There are multiple apps available for smartphones under “health and fitness” or “medical” categories, but around half of them are miss-categorized or only loosely healthcare related.
- Among genuinely healthcare related apps more than two thirds are directly addressed to consumers with no mediation of healthcare providers.
- Most apps provide information to users regarding a particular topic, but less than a half of them also provide instructions and approximately only a fifth of information providing apps can track or capture user data [IMS Institute Report, 2013].
- Lifestyle and health-related apps will be used in a systematic basis and will eventually become an integrated healthcare component. Their functionality assessment will evolve from current user reviews to provider peer reviews, and eventually outcomes evidence assessments.

“In the last years it is agreed by the market, that the only long term sustainable model for health is based on a preventive and personalize planning and tracking”

Diet – mobile apps

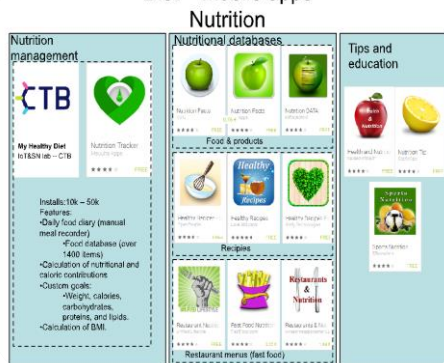

Market potential

- In 2013, over 2.7 billion people are using internet, which corresponds to 39% of the world’s population [International Telecommunication Union, ITU].
- There are now close to 100,000 mobile health apps in 62 app stores, with the top 10 apps generating over 4 million free downloads every day [Research2Guidance]
- Global market for wearable technologies will reach \$5.8 billion in 2018, which represents a compound annual growth rate (CAGR) of 40.8 percent from 2012 to 2018 [Transparency Market Research, 2013].
- Increased adoption of wearable tech: the market is expected to grow to 100 million units by the end of 2014.

Competitive advantages

- HEALTHmate has been designed to strongly benefit of the technologies available at CTB: Internet of Things, Cloud platform and Mobile apps and big data/analytics.
- Anschutz Wellness Center has large scientific supported large experience on preventing chronic diseases through lifestyle modification, providing an holistic concept and intervention programs that encompassed several dimensions of life including mind, body and purpose
- Diet and physical activity dimensions are based on CTB’s My Healthy Diet/Exercise Platform designed to help people to seamlessly adapt their diet/exercise-related daily choices to comply with a set of particular objectives.

References

- The Centre for Biomedical Technology (CTB) is a UPM leading research and technology center that facilitates the development of biomedical technology to be handed over to industry, with large experience in personal health systems.
- The Anschutz Health and Wellness Center and disease prevention on the University of Colorado Denver’s Anschutz Medical Campus is an innovative facility with research and care focusing on alternative and complementary medicines, holistic wellness, weight management and nutrition.

IPR

- Patent granted in Spain [ES2353711]: “Device and method for intake monitoring”.

Development stage

- Concept
- Industrial Prototype
- R & D
- Production
- Lab Prototype

HEALTH-mate contact

Francisco del Pozo Guerrero
Center for Biomedical Technology (CTB-UPM)
e: francisco.delpozo@ctb.upm.es
w: <http://www.ctb.upm.es>

UPM contact

Innovation, Commercialization and
Entrepreneurship Area
Centre of Support for Technological Innovation –
UPM
e: innovacion.tecnologica@upm.es

DOSIRAD. Measuring the levels of electromagnetic radiation

Individual dosimeter device for recording electromagnetic radiation levels

The laboratory of Bioelectromagnetics from the Center for Biomedical Technology UPM (CTB) has developed a pocket individual dosimeter device easily transportable due to its small size, which allows continuous monitoring of the levels of exposure to electromagnetic radiation to which it is exposed the individual device holder.

Technology solution supported by the Technical University of Madrid

Technology solution

The solution comprises a single DOSIRED dosimetric device that allows recording the levels of electromagnetic radiation. Electromagnetic frequency ranges that can be perceived by DOSIRED are included from 50 MHz to 6 GHz in 10 MHz channel bandwidth, so it can record the exposure to different fields emitted by the technologies that surround us in our day to day. Data collected by DOSIRED can be further analyzed using specific software, allowing the creation of a map of the exposure to electromagnetic fields to which the individual is exposed.

"DOSIRAD recorded exposure to electromagnetic fields creating a map of the different places of exposure and the intensity of it"

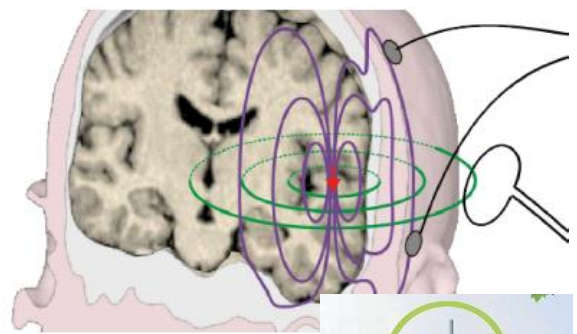

Areas of application

- **ICT:** dosimetry (application to the measurement of electromagnetic fields).
- **Health:** application to the prevention of diseases related to electromagnetic fields, such as cancer or hypersensitivity to electromagnetic fields.



Market demands

- Electromagnetic fields are present in the natural life of the planet from the Sun, the Moon and other sources in the cosmos. Even so, in the last 20 years of urban environments have changed dramatically increasing levels of microwave in 6 magnitudes regarding expected in 1979, mainly by developments in wireless communications, the mass adoption of mobile levels GSM-DCS signals and repeaters associated therewith.
- According to the European Parliament (EP no. 297.574 March 2001) there is sufficient evidence of potentially harmful effects of electromagnetic fields on fauna, flora and human health to react and protect against potentially serious environmental and health risks.
- Most of the regulations regulating emissions EM is based solely on thermal effects, not having taken into account the non-thermal effects evidenced in cases of hypersensitivity to electromagnetic fields.
- The nonthermal effects can cause molecular changes, the breakage of bonds in the DNA strands, alterations in the mechanisms of cellular communication and electric equilibrium of the membrane, which can be translated in diseases like cancer, childhood leukemia, and EHS. Increasing scientific evidence from non-thermal effects begin to appear EHS (electromagnetic hypersensitivity syndrome).

"The levels of microwave electromagnetic fields on 6 magnitudes have risen in 20 years and may be a factor co-promoter of diseases such as cancer or EHS"

Market potential

- Swedish researchers estimate that about 3% of the population has severe symptoms of EHS, and another 35% of the population has moderate symptoms, such as impaired immune system and chronic diseases. [Havas, 2007]
- It is estimated that in 2013 nearly 100% of the population will be covered by a mobile signal. [MIS 2013, ITU]
- In 2011, the average mobile subscriptions per 100 inhabitants was 85.5, while in Spain was 113, U.S. 98, Kong Hon 215 and Italy 159. [World Bank]
- 77.7% of households in developed countries have internet access. [MIS 2013, ITU]
- In 2010, only Spain had 150,000 mobile phone masts, of which half was uninspected. [Europapress]

Competitive advantages

- Current commercial solutions are much larger and more expensive. DOSIRAD has the size and shape of a credit card, which makes it easy to carry in any time and place.
- While current commercial solutions only notified when reach certain exposure limits, DOSIRED allows a broad and continuous frequency sweep (50 MHz to 6 GHz)
- DOSIRED allows to differentiate the sources of electromagnetic fields, as well as to create electromagnetic fields location maps and perform continuous storage of exposure.
- User can take broad electromagnetic fields control thanks to the web site where individuals can view stored data presented in the previous section.

References

- The bioelectromagnetics lab of the CTB is a international reference in the study of pathology and the effects of electromagnetic pollution, with over 15 years of study in this field, publications in research journals with high impact factor and exhibitions in high level international research conferences.

IPR

- Patent granted in Spain [ES2378796]
- International patent application PCT WO2013/128047_A1

Development stage

- Concept
- R & D
- Lab Prototype
- Industrial Prototype
- Production

DOSIRAD contact

Dr. Ceferino Maestú
Laboratorio de Bioelectromagnetismo
Center for Biomedical Technology (CTB-UPM)
e: ceferino.maestu@ctb.upm.es

UPM contact

Innovation, Commercialization and
Entrepreneurship Area
Centre of Support for Technological Innovation
– UPM
e: innovacion.tecnologica@upm.es

CAD. Method to determine the prognosis of patients suffering from Pulmonary Embolism

A new method to automatically detect, segment and measure the heart ventricles in Computed Tomography Pulmonary Angiographies

Pulmonary embolism (PE) refers to the situation when a portion of a blood clot breaks off and travels through the blood stream, typically the deep venous system, passes through the right side of the heart (right atrium and right ventricle), and becomes lodged in a pulmonary artery, obstructing it. Computed tomography pulmonary angiography (CTPA) is accepted as the diagnostic imaging study of choice to confirm the clinical suspicion of acute PE. The right ventricle to left ventricle (RV/LV) diameter ratio is a proven metric of heart strain in patients with CTPA findings of acute PE. However, such ratio is rarely done in clinical practice due to the time spent in finding the location where the diameters of the ventricles are maximal, measuring such diameters and computing the ratios. Knowledge of such metric is key to make the best medical decision for the patient. A research team from the Technical University of Madrid, Brigham and Women's Hospital and Massachusetts Institute of Technology, has developed a Computer Aided Diagnosis (CAD) system to perform such operations automatically, without human intervention.

Technology solution supported by the Technical University of Madrid

Technology solution

Quantification of RV/LV ratio can be done with several methods: volumetric measurements, four-chamber reformatted images or even in axial slices with equivalent prognostic value. Producing such measurement is time consuming and is subject to the experience of the reading radiologists.

The Technical University the Madrid, together with the Brigham and Women's Hospital and the Massachusetts Institute of Technology have designed a completely automated algorithm to compute the RV/LV axial diameter ratio. Without need for radiologists interaction, the algorithm detects the heart, segments the right and left ventricles, detects the inter-ventricular septum and finds the maximum ratio of the right ventricle with respect to the left ventricle to compute the diameter ratio. The algorithm is integrated in the Osirix radiology workstation. The radiologist can review and correct the automated measurements before reporting them to the physician, so that he/she can make the best medical decision for the patient.

"An automated tool that will help physicians making the best medical decision for patients suffering from pulmonary embolism without incurring in extra analysis time of the images by part of the radiologists"

Areas of application

- **Health:** the specific area of application is radiology. The software is integrated in the clinical setting. The system listens to events from the CT machines performing the CTPA, retrieves the associated DICOM images and performs the automated analysis in the background.

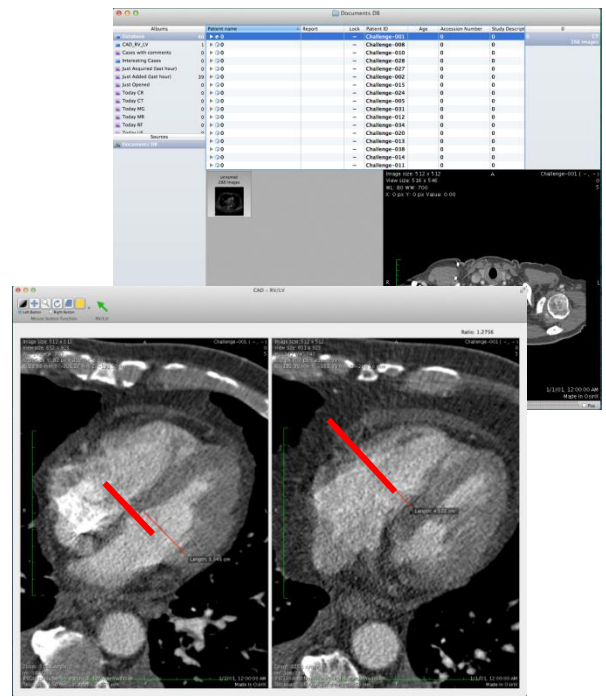

Market demands

- Pulmonary embolism (PE) affects between 300,000-600,000 Americans every year and result in 12,000-80,000 deaths/year in the USA [U.S. Department of Health and Human Services, 2008].
- Accurate numbers for Europe are scarce. However, the incidence of PE has been reported to be 6-20.8 cases/10,000 people/year in Brittany (France) and Malmo (Sweden) respectively [Torbicki et al., 2008].
- There is an estimated number of 60,000 cases of PE a year in Spain, resulting in 50,000 hospitalizations, and more than 19,000 deaths [Juretschke Moragues & Barbosa Ayúcar, 2002] most of them without being diagnosed before death.

“James is a 75 years old patient that presents to the emergency room of the hospital with shortness of breath and chest pain. He is hemodynamically unstable. Luckily the CT scanner is available and a CTPA is performed on James. The radiology report comes and he has a saddle emboli on the pulmonary artery. The physician is faced with a doubt: shall he provide James anticoagulant therapy or is it better to perform a thrombolysis? Thankfully the report from the radiologists also included the RV/LV diameter ratio. Knowing that the RV/LV of James is 1.8, helps the physician estimate the risk of James having a heart arrest, leading to the right clinical decision”

Market potential

- Between 300,000 and 600,000 patients suffer PE every year in the U.S. The average time for a radiologist to estimate a RV/LV diameter ratio is 300 seconds, which at the current salary of a radiologist amounts for 10\$. This gives a total market potential of 6 M\$ in savings. Radiology departments do not report the RV/LV diameter ratio because of such costs.
- While the dollar amount does not seem large, the software solution becomes interesting for teleradiology companies, since they can provide better service with very little extra cost. For instance, *vRad* serves more than 2000 hospitals and radiology groups. Our software can be easily integrated in their workflow. With minimal investment, they can capitalize in such savings by offering the hospitals automated RV/LV diameter measurements.
- An alternative route for commercialization is to embed our software with the already existing radiology workstations. Examples of them are Fuji, Phillips, Vital Images and Siemens.

Competitive advantages

- Performance and robustness have been evaluated within the clinical setting on the routinely diagnostic study of PE (CTPA).
- High accuracy when compared to measurements made by a radiologist, and prognostic significance when tested against reference standards outcomes.
- Having an automated tool will reduce the increase of time spent by radiologists in the computation of such ratio (approximately 5 minutes/case). This will result in savings to the hospital.
- Noise and blur artifacts typically occur in CTPA studies and the timing of the contrast can cause great differences among different CTPA scans. The key improvement of our method, with respect to algorithms designed for other cardiac CT, is the robustness with respect to these effects.
 - This tool can not only be useful in the case of acute PE, but holds promise to be used in other cardiovascular diseases, which are the leading cause of death in developed countries.

References

- Solution developed by the Technical University of Madrid, Brigham and Women’s Hospital and Massachusetts Institute of Technology

IPR

- Provisional patent application in USA [61/909,574]

Development stage

- Concept
- R & D
- Lab Prototype
- Industrial Prototype
- Production

CAD contact

María Jesús Ledesma-Carbayo
e: mledesma@die.upm.es;
Germán González-Serrano; e: ggonzale@mit.edu

UPM contact

Innovation, Commercialization and
Entrepreneurship Area
Centre of Support for Technological Innovation –
UPM
e: innovacion.tecnologica@upm.es

SFS. A new production technology for high performance silk biomaterials

SFS is a versatile and inexpensive production method for fibroin-based biomaterials to produce fibers that combine biocompatibility and high performance

A novel spinning system allows the production of protein fibers under a wide range of conditions, leading to biomaterials with properties that can be tailored for their intended use. Its application to silk fibroin endows the natural material with additional advantages that make it extremely well suited as scaffolding biomaterial for the treatment of tendon and ligament pathologies that demand short-term high mechanical performance along with utmost biocompatibility and cell interaction.

Technology solution supported by the Technical University of Madrid

Technology solution

A novel spinning technology (SFS) allows the spinning of protein fibers through an inexpensive and environmentally friendly procedure that enables adapting the material to its intended use.

Fibroin obtained from silkworm silk is processed into fibers exhibiting the excellent properties of the natural silks (biocompatibility and high performance) and are endowed with emergent properties such as mechanical pre-stressing and biological activity. This new combination of properties makes them ideal for applications in Medicine that range from sutures to scaffolding bioactive biomaterials for cell therapies and Tissue Engineering. In particular, these fibers are especially suited to treatments on diseased or injured tendons and ligaments, where the mechanical performance at early stages is critical.

Areas of application

- **Health:** resorbable or permanent sutures and fixations. Total replacement or reinforcement of tendons and ligaments. High-performance bioactive scaffolds for tissue engineering of tendons and ligaments.

"Biocompatible and bioactive high-performance biomaterials can be used in a wide range of orthopaedic therapies, increasing healing chances and decreasing convalescence time"

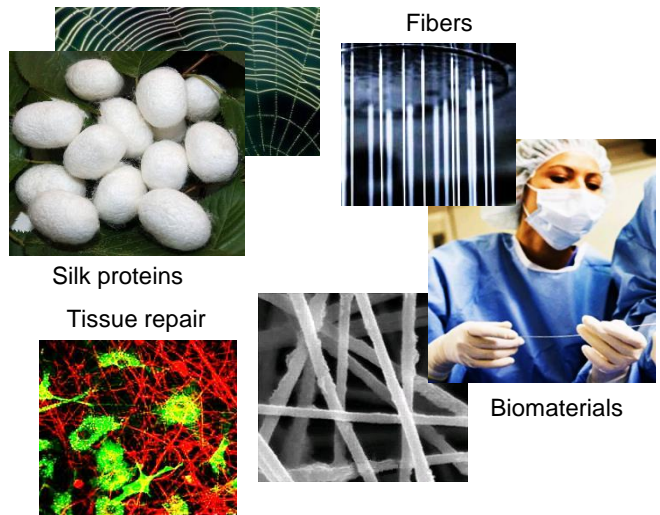

Market demands

- There is an increasing need for the production of high performance, cell-responsive biomaterials for mechanical demanding applications such as sutures, threads and membranes for replacing or reinforcing structural supportive tissues and scaffolds in Tissue Engineering.
- This need is especially evident in the therapy of tendons and ligaments. Present solutions usually require the use of auto- or allografts and does not support early mobilization.
- Current solutions with either biodegradable or permanent biomaterials are largely inadequate; resorbable polymers, such as poly-lactic acid or polycaprolactone, are usually reabsorbed by the body in an uncontrolled manner and permanent polymers, such as polyaramides and polypropilene produce debris upon degradation that leads to chronic inflammation. In addition, these classical biomaterials does not provide an adequate cell environment and mechanical response.
- At present there is not adequate material that can serve as scaffold in Tissue Engineering of tendons and ligaments, due to the required demand of biocompatibility, bioactivity and high mechanical performance.

“An adequate solution for the therapy of diseased or injured tendons and ligaments that prevents the usage of grafts is missing”

Market potential

▪ Health

- Tendon and ligament pathologies represent the second cause of temporary disablement, behind bone fractures.
- Most common affected tendons and ligaments are those of ankle, knee and shoulder. A larger number or injuries are related with sport activities.
- Acute diseases of tendons and ligaments are usually related with work or domestic activities.
- The average cost of surgery in these pathologies is over 4000 euros in case of autologous graft. This figure increases in case of allogeneic graft or with the use of synthetic materials.

Competitive advantages

- SFS technology imparts silk fibroin biomaterials outstanding mechanical properties in terms of strength and toughness, and adds the possibility of incorporating built-in-stresses to produce self-tightening sutures.
- Silk fibroin biomaterials can be presented in several formats from individual fibers to yarns or strips.
- SFS processing preserves the extreme biocompatibility of Silk fibroin biomaterials and can tune their resorbability and bioactivity
- Silk fibers can be functionalized by SFS processing to increase its biological activity with serveral adhesion proteins and growth factors.
- Potential debris from Silk fibroin fibers is composed of proteins, which ensures its natural removal from the organism.

References

- The research group has been involved in the characterization and production of silk fibers since 1998.
- The first regenerated silk fiber with properties comparable to those of the natural material were developed by the group in 2007.

Development stage

- Concept
- R & D
- Lab Prototype
- Industrial Prototype
- Production

SFS contact

José Pérez Rigueiro
e: jperez@mater.upm.es
Gustavo V. Guinea
e: gguinea@mater.upm.es
Center for Biomedical Technology (CTB-UPM)

UPM contact

Innovation, Commercialization and
Entrepreneurship Area
Centre of Support for Technological Innovation
– UPM
e: innovacion.tecnologica@upm.es



IT, Internet & Mobile

IT, Internet & Mobile

In this area it is included all the technologies developed in the field of information and communication technologies, Internet and mobile sector that are not related specifically to other areas of the portfolio: computer and software engineering, networks, big data, social media, middleware, open source...

DicComb.

An application to write well

[Link](#)

GreenCPD

Saving energy beyond the limits

[Link](#)

HandGeometry

Hand biometrics on android

[Link](#)

Liliac

The utmost reliability

[Link](#)

LSE

Automatic Translation into Spanish Sign Language

[Link](#)

Maximum microelectronic efficiency

Compact and ultra low power smart temperature sensor

[Link](#)

Verify

Bringing tranquility to an online world

[Link](#)

VIDEONA

Share your life in a film

[Link](#)

Data Command & Control

Downloading information securely

[Link](#)

SpreadSolver

Deductive spreadsheets for decision support

[Link](#)

IT, Internet & Mobile

MásQueVÍdeo

Unlimited interactivity

[Link](#)

SIDEVAN

Congruence and emotion detection on open source for neuromarketing applications

[Link](#)

MINDZILLA

Mind your mind

[Link](#)

Lynckia

Web real time communications solutions

[Link](#)

πContact

Mobile Solution for Smart Cities

[Link](#)

CUMULONIMBO bigdata platform

Analytics in a wink

[Link](#)

VoteSim

Maximize your clients' social welfare

[Link](#)

EscapeSim

Beyond the emergency drills

[Link](#)

FlowData

The MP3 of databases

[Link](#)

TwitterSimulator

Plan your marketing strategies

[Link](#)

SHANKS

Beyond an interactive network simulator

[Link](#)

Check IT, Internet & Mobile UPM technologies marketplace

[Website](#)

DIC COMB. An application to write well

Web software application for the creation, management and support of combinatorial dictionaries from sets of documents chosen and managed by the user

Writing reports of all kinds, court rulings, a translation, a diagnosis or medical report in a clear and unambiguous way, a language teacher choosing examples and best texts, a lexicographer building a dictionary and looking for representative examples, a journalist looking his best style... have on the bottom the same need. DicComb provides the ability to review material processed from existing documents to enable these people to choose the best way to write something between several proposals. DicComb stands for Combinatorial Dictionary, as this application is based on this kind of dictionary in which the user can manage and process own documents as often as the user likes and then build a customized dictionary and style guide.

Technology solution supported by the Technical University of Madrid

Technology solution

The product is available as a web application for using by subscription or installed in intranets, which includes the ability to upload amounts of documents in different formats (pdf, doc, docx and txt at least) to be processed (debugging, counting terminological term extraction, stemming) at rates exceeding 1.000 words/sec. The result will select either the combinations of words as the representative examples that a user would choose to build a corporate or thematic dictionary that supports copy-editing.

- **why is it different:** there is not a similar application in Spanish language (also in Portuguese and Russian, which are being analyzed to penetrate the market of these languages).
- **why is it innovative:** these tools, which do not exist at the moment, allow the standardization of production methods texts in any field.

Areas of application

- **ICT for social sciences and digital content processing:** network and infrastructure services and digital content.

"Let's combine the words accurately, rigorously and easily"

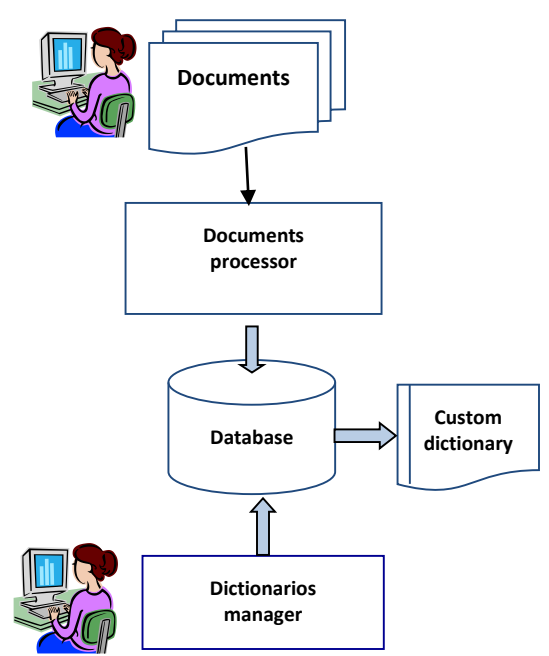

Market demands

- Processing of written texts properly, accurately and in less time, aimed to the following groups:
 - Judges and Lawyers (judgments, orders)
 - Medical / clinical (diagnostic reports)
 - Researchers (description of the language)
 - Language teachers (preparation of teaching materials)
 - Translators (finding the best expression)
 - Lexicographers (construction of dictionaries)
 - Editorials (definition of a style)
 - Journalists (normalization style)
 - Content providers
 - Writers



Competitive advantages

- Reduce time and costs dictionary definition process.
- Increased accuracy and productivity in the drafting of reports and similar ones.
- Developing intuitive and user interfaces for users with less experience in combinatorial lexicography and dictionaries.
- Improvements in knowledge management processes in companies and institutions.
- Low implementation costs as web application.

References

- Supported by UPM Validation and Business Applications Group: more than 20 years experience in this field and international contacts.
- DAIL spin-off creation for the market development (3rd prize in actúaupm competition 2011).
- Group elected in 1996 to represent the Spanish Language in the multilingual Internet project of the United Nations.
- Key group of UNESCO Chair in language technologies (in process of final acceptance).

Development stage

- Concept
- R & D
- Lab Prototype
- Industrial Prototype
- Production

Market potential

- Some figures on the potential would be (pending better evaluation):
 - Lawyers: more than 1,600 law firms over 3 lawyers in Spain.
 - Teachers of Spanish (first language and as a foreign language): more than 18 million students of Spanish in the world.
 - Health care facility
 - Translators
 - lexicographers
 - Journalists
 - Editorials
 - Market analysis done to exploit the solution in Brazil.

DicComb contact (spin-off DAIL Software)

Jesús Cardeñosa
e: carde@fi.upm.es
Carolina Gallardo
e: cgallardo@eui.upm.es
w: <http://www.vai.dia.fi.upm.es>

UPM
spin-off

UPM contact

Innovation, Commercialization and
Entrepreneurship Area
Centre of Support for Technological Innovation
– UPM
e: innovacion.tecnologica@upm.es

GREEN CPD. Saving energy beyond the limits

Application-aware and resource-aware holistic method and tools to decrease energy consumption in data centers beyond the state of the art

GreenCPD provides methods and tools to reduce the total energy consumption pretty much below the available technologies in the state of the art. Unlike previous approaches, we use knowledge about the cooling and computing resources, as well as the applications, and the previous execution history to deliver non-intrusive proactive strategies for minimizing the energy requirements and, at the same time, to increase the reliability of the resources by avoiding thermal hotspots or thermal stress.

The green data center market is rapidly growing. By 2010 data centers consumed 1.3% of worldwide electricity use and produced 2% of total CO₂ emissions. Power density frequently exceeds 60 kW/m². Many data centers already have a lack of power and cooling capacity to meet the needs of such high-density equipment. The flexible GreenCPD architecture will ensure continuous adaptation to present and future requirements, coordinating actions at different abstraction levels and multiple scopes to decrease the total energy consumption beyond the state of the art.

Technology solution supported by the Technical University of Madrid

Technology

Global strategy and tools to use multiple information sources and to coordinate decisions at different levels in the data center aimed at a common objective: reducing the total energy consumption.

Innovative components of the GreenCPD architecture include:

- Automatic energy characterization and classification of the workload.
- Optimal resource selection taking into account cooling resources, computing resources and the applications.
- Leveraging the heterogeneity of the data center to reduce energy consumption.
- Automatic application-aware management of resources, low-power modes, just-in-time compilation, etc.
- Enhanced reliability by avoiding failures due to high temperatures or thermal stress.

"By taking advantage of the heterogeneity of the resources in the data center, the IT energy consumption can be reduced up to 30%"

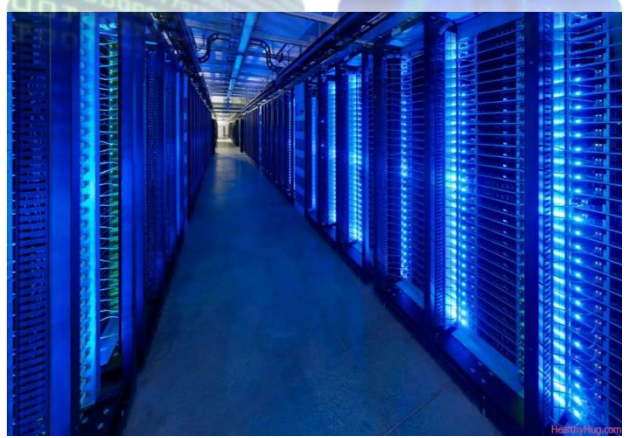

Areas of applications

- **Energy:** energy efficiency
 - Urban data centers: non-intrusive energy optimization of existing data centers, optimal selection of new acquisitions, power outage avoidance, reliability enhancement.
 - New state-of-the-art data centers: energy optimization compatible and beyond the state of the art.

Market needs

- By 2000 data centers used 0.53% of the world's total electricity consumption. By 2010 data centers consumed approximately 235.5 BkWh, representing 1.3% of worldwide electricity use.
- Due to the rapid growth of the data centers capacity, the power densities handled by their infrastructure and energy consumption have grown dramatically. The electricity bill, including computation and cooling costs, is over \$7 billion only in the US and the power density exceeds 60 kW/m².
- According to Gartner, 50% of current data centers already have a lack of power and cooling capacity to meet the needs of high-density equipment. A survey of 369 IT professionals performed by OnStor reported that 63% of survey respondents have run out of power or cooling without warning.

Current data centers need:

- to take into account many different aspects at the same time in order to minimize the total energy consumption, as cooling is not dominant any more;
- to significantly decrease their energy consumption and their peak power needs to avoid power outages, specially in urban data centers during the summer;
- to apply reactive and proactive techniques to adapt the energy consumption to internal and external changes of requirements (peak load or outage avoidance systems of smart grids).

“US data centers consume 1.5 times the electricity consumed by New York City.”

“Worldwide data centers produce 2% of global CO₂ emissions.”

Market potential

- Pike Research forecasts that the green data center will offer an overall market opportunity that exceeds \$40 billion worldwide by 2015. While North America and Europe will lead the way over the next two years, the Asian market will catch up quickly due to the continued rapid expansion of its data center capacity and eventually a growing commitment to the principals of the green data center.
- Microsoft predicts that capital expenditures in new data centers will likely flatten over the next few years as a result of innovations in new designs that bring down cost. However, once these innovations become prolific and further improvement opportunities diminish, the growth will continue at historic rates.
- In 2000, the annual construction market size globally was three times that in the US. By 2020, it will likely be four times as large. This should be no surprise that the growth will be higher globally, than in the US. By 2020, we can expect the construction market size for datacenters to be about \$18 billion in the US and \$78 billion globally.

Competitive advantages

- **Holistic approach.** We optimize energy consumption by taking into account the thermal state of the datacenter, workload energy requirements, thermal and energy characteristics of the cooling and computing resources, and recent execution history.
- **Proactive strategies** besides reactive ones. We use knowledge about workload and resources to anticipate the energy requirements and to plan in advance.
- **Application-aware.** We have proven that, by taking advantage of heterogeneity in IT resources, resource allocation algorithms can be improved to decrease the total IT energy consumption by 30%.
- **Non-intrusive.** Our approach does not require radical changes in the infrastructure nor the management software. Data gathering, data analysis, and automatic control modules can be added gradually with no impact in performance or service discontinuation.
- **Adaptable.** The flexible architecture of our dynamic optimization system can be easily customized to specific needs. The decision support system is continuously learning what works and what doesn't.

References

- CeSViMa-UPM supercomputing center. Reached in June 2011 TOP500 top 1 of Spain, 44 of Europe and 136 of the world, providing a peak performance of 103.4 Tflops and 72.03 of capable TFlops. Also reached position 18 in Green500 (June 2011). Currently installing a prototype.

Development stage

- Concept
- Industrial prototype
- Research
- Production
- Lab prototype

GreenCPD contact

José Manuel Moya
Integrated Systems Lab
ETSI Telecomunicación - UPM
e: jm.moya@upm.es

UPM contact

Innovation, Commercialization and
Entrepreneurship Area
Centre of Support for Technological Innovation
– UPM
e: innovacion.tecnologica@upm.es

HANDGEOMETRY. Hand biometrics on android

Biometric system verification based on hand geometry oriented to mobile devices

The Group of Biometrics, Biosignals and Security (GB2S) within Centro de Domótica Integral (CeDIInt) from Technical University of Madrid has developed a fast and reliable biometric verification system oriented to mobile devices. The system is able to verify an individual based on a hand picture taken by a mobile phone. Main advantages rely on not requiring any contact flat surface, few constraints when carrying out the hand acquisition and a certain resistance against biometric attacks, such as tamper biometrics or spoofing attacks. The proposed system is able to perform a verification within less than 2 seconds in a standard mobile device (smartphone) with an accuracy of 98%, being also able to achieve false acceptance rates close to 0%, which means a great acceptance by the final user.

Technology solution supported by the Technical University of Madrid

Technology solution

This solution is based on a verification software by means of hand geometry, without requiring much collaboration from the final user.

The system is able to verify the identity of a person allowing different degrees of hand rotation and distance to camera, on condition that hand is within a plain parallel to the camera.

The proposed method provides with a unique template for each individual, based on which the system carries out a comparison involving a very low computational cost.

Furthermore, the implementation of this system in Android allows its embedment in any mobile devices based on this former technology.

"The proposed biometric system is able to verify the identity of an individual with false acceptance rates close to 0% in a mobile devices in less than 2 seconds"

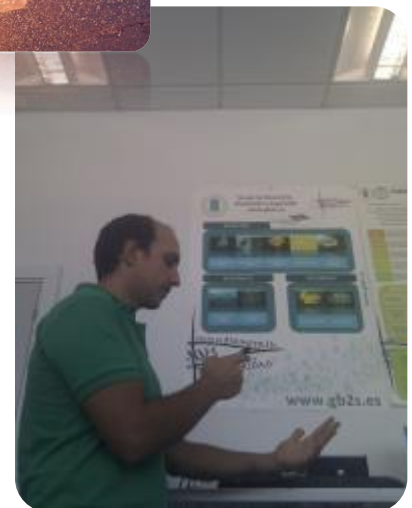

Areas of application

- **Security:** suitable system for carrying out payments on mobile devices, and access protection.
- **Transport:** creation of an electronic ticket associated to the mobile device based on micro-payments.

Market needs

- **Security**
 - Secure systems based on authentication (verification) in mobile devices in order to avoid spoofing attacks.
 - Fraud on payments on mobile devices arises to losses close to 1.13% for each transaction.
 - Security in payment on mobile devices is currently under development and it must be solved in order to ensure user acceptance.
- **Transport**
 - There is a certain need to speed the acquisition of transport tickets in different platforms: underground, train, bus, plane. Save in paper and dedicated devices.
- **Identity verification on mobile devices.**
 - Blocking mobile.
 - Limited access to certain applications in the mobile (mail, agenda).
 - Temping agency to “hire” by mobile phone.
 - Security, alarm management from the mobile device.
 - Bounded to a buying ticket (access to a specific event associated to the service the user has acquired).
 - Adequate age confirmation for visualization in mobile devices.

“The use of biometrics on mobile devices could increase the confidence on mobile devices payment, making biometrics being present on each transaction from a mobile device”

Market potential

- **Security:**
 - Product and services market oriented to biometric security in mobile devices will arise from 30 million dollars in 2011 (concerning 4 million users) to 161 million in 2015 (39 million users).
 - Fraud in payment mobile nets is around 1.13% which implies a market potential of 4,800 million dollars.
 - Biometric market will increase a 22% from 2009 to 2014.
 - Next 5 years, it is expected an annual increase of 54% in pay per mobile (426 billion dollars).
- **Transport:**
 - In 2015, around 500 million persons will use their mobile phones to pay tickets on public transport. [Juniper 2011].

Solution competitive advantages

- No additional hardware is required as only an embedded camera is needed, and nowadays are included within each mobile.
- No flat platform is required to acquired hand picture.
- Low computational cost, being the whole process carried out within the mobile device.
- Advanced prototypes embedded on an Android platform.
- Possible to be used with other devices with cameras (interoperability) and with other programming languages (iOS, Symbian).
- Non-invasive technique and with high user acceptance.

References

- Wide experience on research and development.
- High research interest on this technology solution at national and international level.

IPR

- Software registration M-1274-2013

Development stage

- Concept
- R&D
- Lab-Prototype
- Industrial-Prototype
- Production

HandGeometry contact

Alberto de Santos Sierra, Carmen Sánchez Ávila
e: {alberto,csa}@cedint.upm.es
w: <http://www.gb2s.es>

UPM contact

Innovation, Commercialization and
Entrepreneurship Area
Centre of Support for Technological Innovation-
UPM
e: innovacion.tecnologica@upm.es

LILIAC. The utmost reliability

Security and authentication device for products and brands based on a unique and disruptive technology protected by international patent

Nowadays, 10% of annually worldwide sold products are forgeries. This represents a 600 billion dollars a year loss for brands and manufacturers.

Security and authentication measures used today, such as holograms, are forged easily as exact replicas. LILIAC technology developed by Alise Devices engineers is a new generation of innovative and totally unfalsifiable security device. This technology has been developed in recent years on the facilities of CEMDATIC at ETSI Telecomunicación (Technical University of Madrid).

Due to their performance and features, LILIAC devices are applicable to products of almost all sectors of market. Through inserting them into their products, manufacturers get protection against forgery and a considerable reinforcement of its reputation and brand image.

Technology solution supported by the Technical University of Madrid

Technology solution

Alise Devices offers its customers a unique product whose technology is totally innovative. LILIAC is a plastic and flexible device, which is transparent when it's checked daylight, and with multi-image latent on both sides. These images are individually visible when polarized light or partially polarized light affects the device. This light is emitted by consumption common devices such as mobile phones, a computer screen or an LCD TV, for example.

The three LILIAC product lines (duo, quad and 256) are totally adaptable to the needs of the client. LILIAC can be inserted in any kind product, material or surface. Hidden latent images can be designed according to the client preferences.

"LILIAC technology developed by Alise Devices gives to its holder a unique and innovative authentication system that revalued its brand image and prevent from forgery"



Brand protection

Prevent from forgery

Areas of application

Security:

- **Security and authentication of products and brands:** applied on their products, manufacturers reduce their losses from the sale of counterfeit products.
- **Document security:** application in currency of legal tender, official documents, identification documents and other stamped products.



Current security measures

LILIAC

Market demands

▪ Security and authentication of products and brands

- It is estimated that counterfeit goods market represents 10% of the entire volume of world trade. The annual cost of losses in the global economy due to the trade in all kinds of forgeries is higher than 600 billion dollars.

Some of the most affected market sectors are:

- Medicines&Drugs: with an annual volume of 200 billion dollars. LILIAC is inserted in the packaging or the blister, as a proof of authenticity for users and reducing the losses of the manufacturer.
- Electronic equipment: 100 billion dollars annually. The device is inserted in the packaging.
- Clothing&Accessories: 20 billion dollars annually, inserted in the fabric or on the label, such as distinction system, and as aesthetic and brand image reinforcement.
- Cosmetics&Hygiene: 3 billion dollars annually, as a part of the packaging or the main structure of the product.

▪ Document security

- The main application is in banknotes sector. The European Central Bank found 751.000 forged banknotes during the year 2010. This amount of banknotes accounted for a fraud of more than 40 million euros.
- Authentication system in official identification documents (identity cards, passports, visa, etc).
- Certification of valuable documents.

"It is estimated that counterfeit goods market represents 10% of the entire volume of world trade, amounting to 600 billion dollars annual in losses for manufacturers and brands"

Market potential

▪ Security and authentication of products and brands

- Total market potential for protection and authentication technologies applied in products and brands is estimated at 4.633 million dollar [Reconnaissance International].
- The main substitutes for LILIAC products are holograms and RFID (1.064 and 2.2 million dollars).
- It is a growth sector as demonstrated by the figures of two of its main actors. Bilcare Research net sales increased in a 27% in 2010. OpSec Security Group PLC, as an example of a smaller agent, increased profits in a 15% to 40 million pounds.

▪ Document security

- In 2009, market potential of printing money services was measured in 500 million euros [Pira International].

Competitive advantages

- The unique technological benefits of LILIAC are far exceeding current substitute products.
- Due to its versatility, the device developed by Alise Devices can be inserted in any kind of product.
- Wide range of potential customers in various sectors of the market.
- Integration of the device in the final product as aesthetic reinforcement and upgrading of the brand image.
- Total adaptability of design and features of LILIAC to the client needs.

References

- First prize for the best business plan in the 8th competition of entrepreneurship actúaUPM.
- Award for the best business idea in the 8th competition of entrepreneurship actúaUPM.
- Founding team with more than 50 years of combined experience in the field of technology.

IPR

- Patent: "Procedimiento y dispositivo de seguridad documental por generación de imágenes múltiples".
 - Patent number: ES2337010 B2/ Date: 21/01/2011
 - Patent Cooperation Treaty: PCT/ES2010/000461 / Date: 22/02/2011
 - Patent applied in the USA (US13/513,517) and Europe (EP10845616.1).

Development stage

- Concept
- R & D
- Lab Prototype
- Industrial Prototype
- Production

LILIAC contact (spin-off Alise Devices)

Carlos Carrasco, Beatriz Cerrolaza, Morten Geday, Xabier Quintana, José M. Otón
e: carlos.carrasco@alise-devices.com;
beatriz.cerrolaza@alise-devices.com
w: http://www.alise-devices.com

UPM contact

Innovation, Commercialization and
Entrepreneurship Area
Centre of Support for Technological Innovation
– UPM
e: innovacion.tecnologica@upm.es

UPM
spin-off

LSE. Automatic Translation into Spanish Sign Language

Spanish into Spanish Sign Language (LSE) translation system

The system is made up of a speech recognizer (for decoding the spoken utterance into a word sequence), a natural language translator (for converting a word sequence into a sequence of signs belonging to the sign language), and a 3D avatar animation module (for playing back the signs). Based on preliminary experiments in restricted domains, the translation system performance is close to 100%, operating in real-time. The system allows an easy adaptation to a specific application domain. This technology has been developed by the Speech Technology Group at UPM in collaboration with FCNSE (the Spanish Deaf Association). This technology has been included in several industrial prototypes already developed for different scenarios.

Technology solution supported by the Technical University of Madrid

Technology solution

The system is made up of a speech recognizer (for decoding the spoken utterance into a word sequence), a natural language translator (for converting a word sequence into a sequence of signs belonging to the sign language), and a 3D avatar animation module (for playing back the signs).

The speech recognizer is speaker independent and it is able to recognize continuous speech.

For the natural language translator, three technological approaches have been implemented and evaluated: an example-based strategy, a rule-based translation method and a statistical translator.

Combining these three strategies, it is possible to take advantage from their advantages.

"LILIAC Based on preliminary experiments in restricted domains, the translation system performance is close to 100%"



Areas of application

- **ICT for Health, Ageing Well, Inclusion and Governance:** information and interaction systems with deaf people (information kiosk, cash machines, web pages,...).

Market demands

- Deaf people have a lot of communication barriers that generates a significant number of educational, social and cultural problems.
- **Educational needs of the deaf.** 47% of the deaf population have no education or are illiterate. Furthermore, only between 1% and 3% of the deaf population has completed college, compared to 21% of the entire Spanish population (INE MECED 1999 and 2000/2001).
- **Social integration needs.** Deaf students ends in social guarantee programs 10 times more than the entire student body (INE 1999). Another fact is enlightening that between 45% and 50% of deaf children have psychological disorders compared to the maximum of 25% for the rest of the population (European Society for Mental Health and Deafness 2000). Finally, unemployment is much higher among deaf people, especially among the group of deaf women (INE 2003). These general needs can be specified in the followings points.
- **Subtitled audiovisual content** in sign language. The relevance of this aspect is increasing given the Law about Audiovisual Communication 2010, which imposes very high subtitling needs, requiring automated tools.
- Translation of **web pages** into sign language to facilitate deaf people accessing them.
- Generation of information in sign language to be provided through **information points or cash machines**.
- Content translation into sign language for **education and training** of deaf people.

Deafness gives rise to significant communications problems. With this technology it is possible to develop content and services accessible for deaf people.

Market potential

- According to the Survey of Disability, Personal Autonomy and Dependency Situations INE (EDAD, 2008), the number of people with disabilities are: 3,847,900 people, more than 8.5% of the population. The number of hearing impaired is 1,064,100, ie 25.20 per thousand population.
- From the recognition of LSE (Spanish Sign Language) as an official language in 2007, the number of LSE users is growing significantly.

Competitive advantages

- Translation rate is close to 100% for restricted domains (<1000 words).
- Real-time operation for on-line interaction services.
- Speaker independence when translation from speech.
- Easy adaptation to a specific application domain.
- Flexible to be adapted to other languages or sign languages.
- Available a sign vocabulary with more than 1000 signs. This vocabulary includes a description of every sign in both SEA (Sistema de Escritura Alfabética) and HamNoSys.
- These signs are already generated. They can be used in different contexts: it does not require re-design them.
- There is a user-friendly visual tool for designing new signs in both HamNoSys or SEA.

References

- Research group with wide experience in this subject and collaboration with companies.
- This technology has been developed in collaboration with FCNSE (the Spanish Deaf Association).
- There are several industrial prototypes already developed for different scenarios: Identity Card renewing, Driving License renewing, Hotel reception and Information Point of the EMT.

Development stage

- Concept
- R & D
- Lab Prototype
- Industrial Prototype
- Production

LSE contact

Rubén San Segundo Hernández
e: lapiz@die.upm.es
José Manuel Pardo Muñoz
e: pardo@die.upm.es
w: <http://gth.die.upm.es/>

UPM contact

Innovation, Commercialization and
Entrepreneurship Area
Centre of Support for Technological Innovation
– UPM
e: innovacion.tecnologica@upm.es

Maximum microelectronic efficiency

Compact and ultra low power smart temperature sensor for on-chip thermal management: high performance and reliability of electronic devices

A research team of the Higher Technical School of Telecommunications Engineering at the Technical University of Madrid (UPM) has developed an advanced sensor for the dynamic thermal management in electronic circuits. This temperature sensing is key factor to integrated circuits (chips) performance, and therefore, to all kind of electronic devices or components. The demand for reliability and best performance in microprocessors applied to computation is rising, focused on computer multi-core architectures, graphic processing units or smartphones. The sensor improves previous results in terms of area and power consumption (first class circuits design constraints) by more than 85% .

Technology solution supported by the Technical University of Madrid

Technology solution

This solution is based on a tiny ultra low-power smart sensor, specially suitable for Dynamic Thermal Management (DTM) techniques and the detection of possible on-chip hot spots.

It stands out for a robust design against chip self-heating effects, for a fully compatibility with standard CMOS processes and for an easy integration of these sensors in VLSI (*Very Large Scale Integration*) layout, as well.

Furthermore, a specific interface that can be integrated into the sensor has been implemented to digitalize the temperature sensing. This advantage implies a significant cost savings comparing it to previous works, which usually consider this A/D conversion in their design.

Areas of application

- **ICT applied to embedded systems:** microelectronics supporting advanced electronic devices performance (PC, smartphones, graphic processors, automotion...).

"Sensor characterization work outperforms previous solutions by more than 85% as far as area and power consumption are concerned"

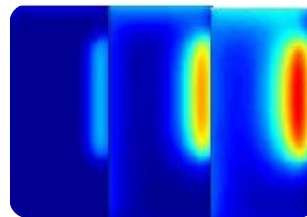

Market demands

- Integrated circuits (chips) production and optimal design: key constraint in advanced electronic devices performance evolution, from mobile handsets to server systems, through all kinds of electronic devices.
- High integration densities in digital circuits, that implies an important rise in heat density (on-chip hotspots).
- Temperature management and sensing is a chip critical design constraint and, therefore, it impacts on a large number of applications: circuit reliability and performance degradation risks.
- Chips design and manufacturers firms must face new challenges by providing thermal-efficient systems that support electronic performance evolution.
- Traditional on-chip cooling solutions, that affect the whole chip instead of targeted regions, imply an inefficiently overcooling (rising both costs and required area).
- Industry's interest focused on circuits designs that take power and thermal management functionalities into account: higher performance, higher efficiency and lower size requirements.
- The increasing demand for longer mobile devices battery life and its rapid adoption (16% increase in smartphone usage year over year; global sales expected to top 500 million units in 2014) require an improved circuit design with a more efficient power performance and temperature management.

“A dynamic and efficient chip temperature management is a success factor to support the rising demands for high performance and reliability of consumer electronics devices (e.g. smartphones)”

Market potential

- Semiconductor global market grew by 29.3% to reach a value of 400.000 M\$ in 2010. Integrated circuits is the largest segment of this market, accounting for 80% of the market's total value. [Datamonitor]
- Forecasted increase of 33% during 2010-2015; market boosted by consumer electronics devices demand. Asia-Pacific region accounts for 66% of the semiconductor market value. [Datamonitor]
- China, the second largest producer of semiconductors in the world, is poised to grow even larger over the next years due to government's decision to invest 50.000 M\$ in semiconductor related projects. [GBI Research]

Competitive advantages

- DTM (*Dynamic Thermal Management*) techniques implementation: energy and thermal-efficient solutions.
- 85% reduction in power consumption comparing with previous solutions (1.05–65.5 nW at the conversion rate of 5 samples/s).
- 85% reduction in area of the sensing part comparing with previous results (very reduced area: 10.250 nm²).
- Specific interface designed to digitalize the temperature sensing, compatible with the sensor, that allows a lower cost implementation comparing with previous results.
- Fully compatibility with standard CMOS processes, technology widely used in microprocessors, semiconductor memories or signal processors designs.
- Easy implementation: possibly be included in any standard-cell library for designing integrated circuits.
- Flexible enough for leaving the interface up to the designer's necessities.

References

- Wide research background and collaboration with industry.
- Worldwide research interest in this technology solution (relevant scientific citations).
- Innovation background: university spin-off creation and involved in 3 patents.

IPR

- Patent granted in Spain [ES2291143]

Development stage

- Concept
- R&D
- Industrial Prototype
- Production
- Lab-Prototype

Technology solution providers contact

Pablo Ituero Herrero, Marisa López Vallejo
e: {pituero, marisa}@die.upm.es

UPM contact

Innovation, Commercialization &
Entrepreneurship Area
Centre of Support for Technological Innovation –
UPM
e: innovacion.tecnologica@upm.es

VERIFY. Bringing tranquility to an online world

Efficient and targeted management of online reputation, privacy and trust.

In an ocean of personal and corporate information, how can we assure the contents we find are truthful? And when that information refers to ourselves or our companies, how can we ensure our online appearance?

A research group of the Telematics Systems Engineering Department (DIT) at UPM (Universidad Politécnica de Madrid) has developed a technical solution that funnels all this information, bridging the gap between referred users and information consumers. We offer tailored value propositions targeting different industries where reputation and trust provide an added value. Our technology allows consumers to verify the information they find online and check it with the referred users, who may in turn acknowledge or deny that and defend their position.

We increase the quality of personal information retrieved by consumers at a reduced cost, as well as we ensure their perception matches the intents of the referred users. We offer tailored value propositions targeting different industries where reputation and trust provide an added value, with several demonstration prototypes available.

Technology solution supported by Universidad Politécnica of Madrid

Technology solution

Verify provides a set of software modules allowing that:

- Users referred by online contents can acknowledge or deny that information, reaching those who consume it.
- Users consuming online contents may directly check it with the people or companies it refers to.

They stand out for letting referred users modulate the perception others get about them, as content consumers directly obtain the view of those that might be concerned.

Moreover, it includes specific components for information consumers, information producers and referred users, deployed as add-ons that integrate within different systems (application servers, user browsers, search engines, etc.), and communicate through novel protocols.

Areas of application

- **ICT applied to digital contents:** information service providers aiming to serve quality contents that include personal information (e.g. social networking services, etc.)
- **ICT applied to service and network infrastructures:** network and service providers mediating between people who consume information and people referred by it.

"Verify may allow information service providers to boost user engagement and expand their premium services, as it improves the quality and credibility of the contents they deliver"



Market demands

- **ICT applied to digital contents:**
 - Online reputation management: 80% of users in continental Europe take steps to manage their online reputation. [Microsoft]
 - Personal branding: a good quality of a user's online presence may be a guarantee to succeed in finding a new job, meeting people, etc.
 - Conversely, bad online reputation may ruin personal growth opportunities. 70% of recruiters dump candidates based on their online records; same as 43% of online dating services do with potential dates.
 - Human resources: 90% of recruiters spend the equivalent to €7 to verify each candidate's reputation.
 - Social relations: 45% of users believe their reputation can get or prevent them to meet people.
 - Mass media: scandals arise when they provide low-quality, unverified information.
- **ICT applied to service and network infrastructures:**
 - Social Networking Services are taking on decentralized, federated and interoperable models. Now, the social network provider does not control the contents it serves any more. Allowing users to take back the helm of their personal information is a key factor to succeed in this new scenario.
 - Loss of online privacy: top concern in 2020 for 45% of European Internet users.
 - Do-Not-Track regulations in US and EU to ensure users privacy: estimations on similar initiatives show 10% of registered users would pay \$5 a month for privacy protection

"I cannot control who may seek or come across online information about myself. But ensuring they ultimately encounter a good reputation about me is key to succeed in finding a job"

Market potential

- Online Reputation Market amounts to the equivalent of \$3.75 Bn worldwide, with a 30% annual growth [e-Consultancy].
- Identity and reputation as an economic asset: successful identity certification services exist that charge \$50 to verify user attributes.
- Online privacy: products usually charge individuals with \$7 – \$18 monthly installments for preventing access to their personal data.

Competitive advantages

- Previous reputation management solutions used to be based on recurrent screening and information flooding, which have proved to be quite inefficient and require to spend a lot of resources. Verify provides a much more **cost-effective** way to ensure our appearance reaches the consumers as we intend, since it directly channels information from the referred users to the content consumers.
- Verify solutions are inherently **dynamic**, so they allow easily managing new information as soon as it appears.
- Verify solutions work **robustly** even on massively distributed environments where no previous trustworthy relationships exist between the domains of the consumers and the referred users.

References

- Verify: infrastructure prototype and user tools for OneSocialWeb (Vodafone).
- Finalists at entrepreneurship competitions: Wayra, ActuaUPM
- 4-year Cenit Segur@ project on security, privacy and trust management, contracted by Ericsson, resulting into 5 patent applications.
- Combined 40+ year experience in R&D on digital content solutions (customized search engines, usability and user experience, etc).

IPR

- European patent applied [EP11719292.2]

Development stage

- Concept
- R & D
- Lab Prototype
- Industrial Prototype
- Production

Verify contact

Yod Samuel Martín, José M. del Álamo,
Juan Carlos Yelmo
e: {samuelm, jmdela, jcyelmo}@dit.upm.es

UPM contact

Innovation, Commercialization and
Entrepreneurship Area
Centre of Support for Technological Innovation –
UPM
e: innovacion.tecnologica@upm.es

VIDEONA. Share your life in a film

Social network for sharing user-generated video content from mobile devices.

G@TV, a research team from the Technical University of Madrid has developed Videona, a tool created to meet the needs of the new digital natives. Videona can record and edit clips on your own mobile device. Share them immediately to your beloved ones. Create a new video combining multiple multimedia assets (images, video, audio...) just in a few steps!

Film what you feel, share what you love... that's VIDEONA, your new Social network to share your videos and compete with your friends with a rewards system.

Currently, the first version of Videona has already reached 130,000 downloads [October 2013].

Technology solution supported by the Technical University of Madrid

Technology Solution

Videona provides a powerful set of tools to manage your video creativity everywhere, anytime. Videona integrates recording and editing solutions and makes you free to select multimedia assets in your mobile device and create new personalized content within the terminal. It has been implemented to allow a complete independency of the network status, and to save the result immediately in our device.

Videona capabilities can work besides any other social network at the wish of the user or in its own social network, because the videos are both, on the device, and in the Videona's cloud servers.

Areas of application

- **Social Network:** This product is focused on user generated video sharing that is now trending and is widely demanded by users.
- **Digital Content:** Allows the video recording and editing in a mobile Android device, no huge servers are needed.
- **Mobile Apps:** Videona is software application designed to run on smartphones, tablet computers and other mobile devices.

"Videona allows video recording and editing in a mobile device, and, the possibility to share it immediately with your friends through a social network"



Market demands

▪ Social Networks

- Social networks like Facebook, Hi5 or Twitter aim to provide people interaction tools. Nowadays, they are considered the best way to communicate the user with its relatives. In fact, it is quite usual that people publish on them a picture from an event they recently attended. After the assimilation of image in the social networks the next step is to move forward the video sharing, being all the major Social networks already developing their own video editor for mobile devices.

▪ Mobile apps in Multimedia and Video sector

- The growing market share from smartphones that are equipped with a video camera and powerful processing units, has contributed to a increasing demand on Apps for smartphones that use these capacities. Countries like USA (12,82%), South Korea (8,14%) or even Spain (2,36%) are on the top ten leading countries in downloads on this kind of applications. On average, an user spends in average around 6 Euro in apps. According to some market analysis Apps based on video editing has its own market gap.

“The major Social Networks are looking forward to sharing user-generated videos over them”

Market potential

▪ Social Networks

- Twitter has developed Vine, its own video edition app, which has been downloaded more than 50 million times. The shares of Twitter have jumped 73% in its market debut.
- Facebook bought Instagram for 1B\$ in April 2012, allowing their users to edit videos and the addition of color filters to their creations. Last year registered access from mobile devices have increased a 46%. Facebook actually has 874 million users, from which around the half of them use Instagram tool.

▪ Mobile apps in Multimedia and Video sector

- There are more apps that allow users to share videos like Socialcam or Viddy. Despite they have less users that the majors, their numbers are outstanding (up to 5 millions downloads each). There are also video editing apps like VidTrim or WeVideo but the process is not carried out in the device.
- Usual business model is based on free applications and revenues mainly acquired from advertisement sector. For instance, Facebook incremented 60% on the company benefits in October 2013 thanks to the incomes due to mobile advertisement.

Competitive advantages

- Video editing can be done in the own mobile device. Intuitive and easy to use interface
- Users can record and edit videos instantaneously.
- Editing videos up to 45 seconds long.
- Videona, thanks to its free video editor VideoZone, allows users to combine up to 5 multimedia assets from any type (images and/or video) and duration, as well as an audio stream can be added over the whole creation.
- Resolutions adapted to the capabilities of the terminals
- It is possible to publish custom clips in the desired social network user or Videona own social network.

“VIDEONA is following a Freemium approach and can be downloaded for free from Google Play. The evolution to a Premium version will allow adding performance improvements (i.e. less time in video creation, color filters and unlimited number of multimedia assets). Integration with major Social networks and gamification are key elements for the successful evolution of this tool”.them”

References

- Research Group with experience in the field of audiovisual media and networking technologies.
- Videona can be downloaded for free from Google Play. It has achieved more than 130.000 downloads in 10 months during 2013 [October 2013].

Development stage

- Concept
- R & D
- Lab Prototype
- Industrial Prototype
- Production

VIDEONA contact

Nuria Sánchez, Iago Fdez-Cedrón
{nsa,iff}@gatv.ssr.upm.es
w: <http://www.videona.es>

UPM contact

Innovation, Commercialization and
Entrepreneurship Area
Centre of Support for Technological Innovation
– UPM
e: innovacion.tecnologica@upm.es

Data Command & Control. Downloading information securely

The system can manage access to the intelligible information previously possessed, based on the use made of it.

The information can be possessed but not be accessible (understandable). In general the two concepts come together. Data Command & Control is a system that detaches both concepts: possession and access. This is achieved through cryptographic protocols while offering security and authentication. Only intelligible or understandable access to information possessed be achieved if the use is reasonable and appropriate under the rules of the system. So, someone may be holding information but could not access its contents while the behavior or permissions are not appropriate according to the rules of the dynamic system. Thus Data Command & Control allows to generate a series of contractual relations hitherto nonexistent: legal, commercial or copyright.

Technology solution supported by the Technical University of Madrid

Technology solution

- The possessed information is not accessible or intelligible by being encrypted.
- The Data Command & Control system allows deciphering the information possessed in a controlled manner.
- Decryption speed or access to information depends on the more or less massive download.
- The system provides security by cryptographic protocols used to control the information speed for proper use.

"Information control, decoupling possession (not comprehensible) of access (comprehensible), offering new administrative methods under the frame of copyrights, and organizational and administrative privileges"

Areas of application

- **ICT**
 - Services and network infrastructure: peer-to-peer services, data servers and massive downloads of information.
 - Digital contents: audio-visual industry, literary works, museums, documentation and mass information.
- **Security:** administrative and legal procedures, organizations with restricted access of information management (Defense, corporations, etc.).



Market demands

▪ Security

Administrative and Legal Systems

- Sometimes in administrative and legal processes, it is necessary to differentiate between ownership and the right of use. To be the owner of a particular knowledge or be able to use it, generate different scenarios with usually different responsibilities and requirements associated.

Organizations with restrictions on access to information

- Information is now considered an intangible asset of high value, therefore its access and use will become increasingly sensitive.
- 67% of the Spanish big companies lack of technical mechanisms to prevent leakage of corporate information. Furthermore, although 86.5% of companies have rules of use of ICT resources corporate, only 15.6% performed continuous monitoring of compliance [Ribas and Associates, 2012].

▪ TICs

Audio-visual and literary sector, artworks, P2P, bulk downloads, etc.

- Currently, there is full availability and access to the information on Internet because of the high discharge capacity of all types of digital content such as music, films, and digitized works, etc. and in many cases copyright are being violated.

“The proposed solution allows a paradigm shift in the availability of information, because make possible to distinguish between the ownership of information and the right to use it”

Market potential

- Increased spending on software and hardware DRM (Digital Restrictions Management) is expected in order to protect the entertainment, commercial software, and other information [RNCOS, 2011].
- It is estimated that the market for DRM will grow around 25% during 2013-2017. Specifically the market for mobile content will be one of the key drivers for the growth of the DRM industry. [Reportlinker, 2013].

Competitive advantages

- Representing a paradigm shift or a change in the information model.
- Providing the possibility to differentiate between be the owner of a particular knowledge and the right of use, with clear legal references.
- Joining company roles and access to security systems solving the problem of possession and access, which before has been considered the same.
- Addressing the full access to information, through the minor or major slowdown in access, and preventing excessive greed or ambition on the content (unless you pay for it exponentially)
- It avoids commercializing large volumes of data to third parties.

References

- Extensive research and collaboration with ICT and security companies.
- Research group oriented to innovation and commercialization of the results.
- High commercial interest in this technology solution at the national and international level.

IPR

- Patent granted in Spain [ES2363355]

Development stage

- Concept
- R & D
- Lab Prototype
- Industrial Prototype
- Production

Data Command & Control contact

Vicente Jara Vera; Carmen Sánchez Ávila
e: gb2s@cedint.upm.es
w: <http://www.gb2s.es>

UPM contact

Innovation, Commercialization and
Entrepreneurship Area
Centre of Support for Technological Innovation –
UPM
e: innovacion.tecnologica@upm.es

SpreadSolver. Deductive spreadsheets for decision support

The combination of spreadsheets with automatic deduction techniques allows identifying common errors, working with incomplete information, solving complex problems and facilitates networking.

SpreadSolver integrates advanced programming language technology with spreadsheet interfaces to attack some of the most common causes of errors, such as operations between incompatible operands (e.g. adding yards and euros), handling undefined or incomplete values or circular references among cells. Our solution extends the traditional spreadsheet model in which each cell is either a constant or a value calculated from other cells, allowing the possibility of complex relationships between cells that are able to detect inconsistencies or reconstruct values out of partial information. Moreover, these new features allows applying the spreadsheet model to new problems, even when some of them had not been addressed before in this way. SpreadSolver has been developed by the Babel research group at the Technical University of Madrid.

Technology solution supported by the Technical University of Madrid

Technology solution

SpreadSolver allows you to use spreadsheets differently as you were used to. Having cells with incomplete values (e.g. set a range of values), establishing relationships between sets of cells (e.g. force them totaling 100) or properly handle circular references among cells is possible through the use of automated deduction techniques.

These same techniques also detect inconsistencies that are the source of some of the most common mistakes in the use of spreadsheets.

Our smart spreadsheets solution allows addressing issues previously not supported by traditional spreadsheets including combinatorial problems such as planning, scheduling or resource allocation.

Areas of application

- **Business intelligence:** as a safe replacement for spreadsheets in decision support environments, and as an alternative to ad-hoc solutions.
- **ICT for the social sciences and digital content processing:** due to the ubiquity of the use of spreadsheets and the generality of our approach.

"SpreadSolver, a smart sheet with powerful deductive capabilities without sacrificing the ease of use of traditional spreadsheets"

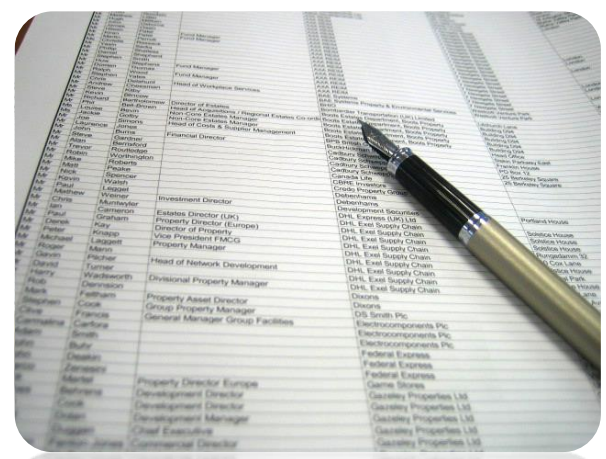

Market demands

- Millions of users around the world have interacted with a spreadsheet some time or another. They are considered one of the earliest and most successful examples of what has been called end-user development (EUD), perfectly embodying its three defining characteristics: high availability; immediate effect of the changes, and easy reuse. These same features (especially the last one) lie also behind some of their drawbacks.
- Repeated and unrestricted copy, cut and paste actions by unskilled users can lead to large, difficult to maintain and understand sheets, which can lead to unpredictable behavior.
- According to a study from PWC, 95% of the Excel™ spreadsheets examined had errors out of which 80% had significant monetary errors (i.e. spreadsheet gives an incorrect result). Moreover, errors seem to occur in a small percentage of all cells, meaning that for larger spreadsheets, the issue is not whether errors exist but how many errors there are. Consequently, a number of companies base critical decisions on misstated numbers and questionable analyses [PwC, 2009]. KPMG makes similar estimations.
- The societies are increasingly dependent on mobile devices and technologies that support and foster networking. So, collaboratively developing documents among several people using the cloud is no longer an option but a necessity, as evidenced by the rise of tools like Google docs.

“SpreadSolver can integrate data from multiple sources without losing consistency”

Market potential

- Increase in the supply of advanced platforms and business intelligence services with the intention to "run away" from spreadsheets and their associated problems, as in the case of business suites such as SAP and similar.
- Nearly one third of organizations either already use or plan to use a cloud solution, or software-as-a-service (SaaS) mode to increase its base of business intelligence capabilities [Gartner].
- The business intelligence industry will grow 7% annually in the 2012-2016 period, driven primarily by the demand from Asia-Pacific. The segments that will have a greater development are advanced analysis, data management, planning and corporate performance management [Pierre Audoin Consultants].

Competitive advantages

- Our solution reduces the possibility of errors in spreadsheets, especially those that handle sensitive company data, such as financial, causing millions of euros in losses.
- Integration with Google docs, which facilitates its use in mobile and collaborative environments.
- The extended model of spreadsheet advocated by SpreadSolver solves problems like time and resource planning using a graphical language already known to users of spreadsheets.
- SpreadSolver, being based on open, semantically rich textual formats, facilitates collaborative work through versioning systems, because the sheets can be merged more easily than traditional ones.

References

- Babel research group has over 20 years' experience in research and the application of logic to SW development and programming languages.
- Regular partners to some of the main European and Spanish technology companies.

Development stage

- Concept
- R & D
- Lab Prototype
- Industrial Prototype
- Production

SpreadSolver contact

Julio Mariño
e: jmarino@fi.upm.es
Ángel Herranz
e: aherranz@fi.upm.es
w: <http://babel.upm.es>

UPM contact

Innovation, Commercialization and
Entrepreneurship Area
Centre of Support for Technological Innovation
– UPM
e: innovacion.tecnologica@upm.es

MÁSQUEVÍDEO. Unlimited interactivity

Services and applications for improving reproduction and interactivity for digital video over last generation technological supports

MásQueVideo aims to provide a set of services focused on multimedia terminals and digital television. It has been developed by a research team, with more than 15 years experience in this area, from the Escuela de Ingeniería de Telecomunicaciones - Technical University of Madrid (UPM) and in collaboration with other research centers in the European Union. MásQueVideo considers the latest developments in the encoding/decoding of digital video, offering them to the companies. Thus, users can enjoy multimedia contents on different media supports and platforms, such as last generation TVs, tablets or smartphones, enhancing the interactivity of the clients, offering advantages to the content broadcasters and improving the features of the software that implements the solution. Further researching lines are followed, they will incorporate coming developments in the field, improving costs and incorporating new capabilities

Technology solution supported by the Technical University of Madrid

Technology solution

MásQueVideo is a set of software applications for the digital video decoding. It takes into account the last video encoding standards and it will offer interactive services that will enhance the users experience. This solution offers a 50% reduction in the bandwidth consumption as it is based on the new HEVC standard. It is also designed to be used over a wide range of devices as tablets or smartphones, including improvements in the power consumption of around a 20% of these terminals. MásQueVideo is integrated into the H2B2VS European project, and it will provide new interactive services as multiview, social TV or personalized advertising.

"MásQueVideo provides an innovative and complete solution for video streaming to digital televisions and mobile devices"

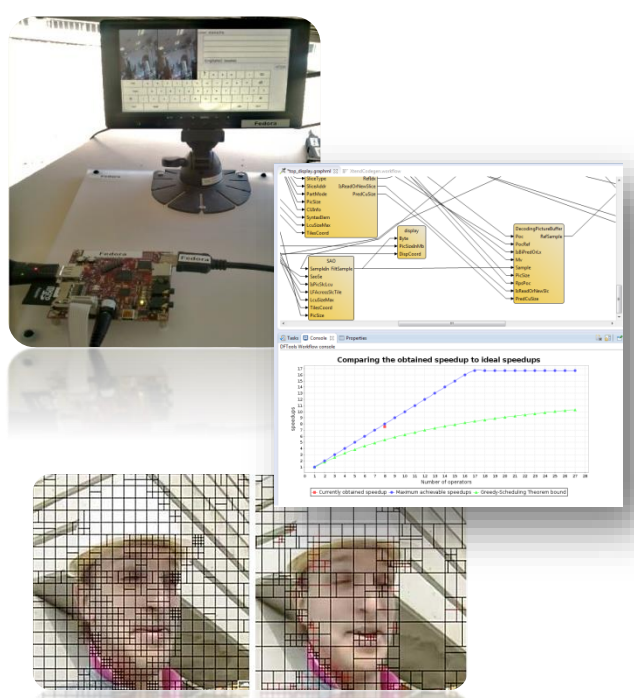

Areas of application

- **ICT applied to digital content:** introduction of the new encoding/decoding HEVC standard for digital video, new interactive services, reduction of energy consumption. Furthermore, personalized advertising will be available according with the clients tastes.

Market demands

- **Digital TV**
 - The steady increase in the resolution and quality of video sequences requires implementations of new coding standards, they should allow the video broadcasting at acceptable data rates.
 - The high cost and the limitation of available frequency bands for digital video broadcasting of digital television becomes a problem for broadcasting companies.
 - There is a need for new interactive systems that allow higher interaction levels for customers according to their preferences.
- **Mobile devices**
 - The limited computing capacity of mobile processors require more efficient solutions which permit the reproduction of new media contents
 - The limitations with the batteries of this kind of devices require a better use of them and improvements for a lengthen batteries life.
 - Increasing of mobile devices achieved in last years need a better synchronization and compatibility with classic media supports.
- **Advertising**
 - Necessity to offer targeted advertising to customers based on their tastes and interests.

“The increase in the number and types of devices that allow the enjoyment of multimedia content, as well as improvement in the quality of the contents, require new solutions that break with previous standards”

Market potential

- **Digital TV**
 - International demand of new video decoding systems, innovative and easy developing of them [Cisco Systems].
 - The H.265/HEVC standard has been accepted as sucesor of the H.264 standard, currently used for digital TV broadcasting, by the International Telecommunications Union (ITU).
- **Mobile devices**
 - The smartphones are nowadays more than the 50% of the mobile phones all over the world [IDC consulting].
 - The number of tablets and smartphones users who watch media in streaming with their devices have been significantly increased in last years.

Competitive advantages

- Incorporation of the new video coding standard HEVC that allows a reduction of 50% of the bandwidth required for the transmission of the same quality contents compared to the currently used standard (H.264).
- The high cost and the limitation of available frequency bands for digital video broadcasting of digital television
- Improvement in energy consumption of around 20% for mobile devices, also allowing the change of the video quality to permit extend the battery life.
- Incorporation of new reconfigurable video standards (RVC) that allow rapid adaptation in the process of developing new software enhancements for video decoding.
- Currently there are competitors developing solutions for video decoding HEVC, however, MásQueVÍdeo offers to the users a higher degree of interactivity more comprehensive and innovative. It also include better performance for operation in mobile terminals.

References

- Research group with over 15 years experience in ICT themes and digital video processing.
- The group has participated in numerous national and international researching projects as Power Consumption Control in Multimedia Terminal (PccMuTe) PRTO-TVD project or the Celtic Plus H2B2VS European project.
- Continued research based on low cost multicore Digital Signal Processors (DSPs) to improve the performance and cost of current systems for processing platforms.

Development stage

- Concept
- R & D
- Lab Prototype
- Industrial Prototype
- Production

MásQueVÍdeo contact

Miguel Chavarrías Lapastora, Fernando Pescador del Oso

e: miguel.chavarrias@upm.es

w: <http://www.gdem.sec.upm.es/es/>

UPM contact

Innovation, Commercialization and Entrepreneurship Area

Centre of Support for Technological Innovation – UPM

e: innovacion.tecnologica@upm.es

SIDEVAN. Congruence and Emotion Detection on Open Source for Neuromarketing Applications

Application to monitor the degree of trustfulness in spoken messages on VoIP systems for neuromarketing and contact centers

The basic technology for the development of these systems relies in the advanced speech processing for the extraction of biometrical and emotional marks in phonation, difficult to be forged, and of high statistical reliability. This technology has been developed and patented by the team responsible of this technological offer, and is being used in restricted fields of Medicine, Neurology, Teaching, Homeland Security, Police Forces and Speaker Biometry. This technology is oriented to develop a special line devoted to electronic commerce and contact center assistance in **neuromarketing** and the **web of things**. Its main applications are to be found in platforms and services for commercial transactions by VoIP, emergency contact centers (health systems, catastrophic events...), tele-assistance to handicapped, third age, gender violence, threat to persons and facilities, tele-banking, etc.

Technology solution supported by the Technical University of Madrid

Technology solution

The solution proposes an integrated man-machine interface to monitor the emotional state and the truthfulness degree on discourse systems based on VoIP supporting a specific attention service. This interface offers an *on-line* description of the spoken discourse, event spotting with *semantic atoms*, the production of *html* messages to attention servers, the documentation of each transaction regarding impact factor and legal and contractual conditions, etc.

This solution offers a substantial improvement on the treatment of client-service relations regarding *Customer Resource Management* as well as *Customer Oriented Services* creating a three-band fully automatized framework: Client-Server-Supervisor.

Areas of application

- Networking: Medicine, Homeland Security, Banking
- Advanced -eHealth and Personal Care
- Independent Life, e-Inclusion, Self-governance

The objectives of this technology are prioritizing user attention in resources and personnel, optimize transaction impacts, and associate statistical and juridical documentation

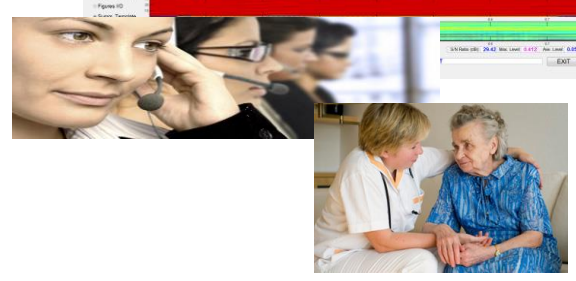
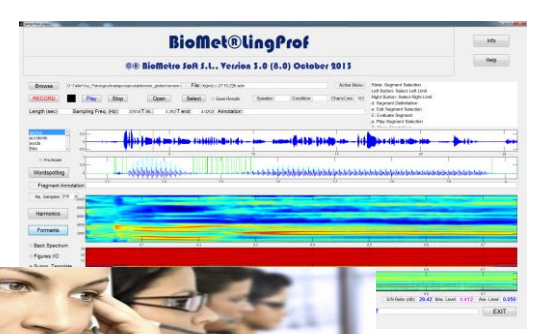

Market demands

- **Secure Access to Facilities and Services**
 - Identity verification in health attention services, emergencies (gender violence, homeland security, third age attention, e-Health, etc.)
 - Restricted access to applications and services for companies and institutions based on voice biometry.
 - Oriented to public and private agencies in health services, third age care, security-based contractual services (juridical advice, financial advice, commercial and investment banking, etc.)
- **Customer Resource Management/Oriented Services**
 - Non face-to-face contracting services, customer attention incidence handling, VoIP marketing services, call-handling protocols in security centers (gender violence, threats to persons, facilities or resources)
 - Tele-assistance and contact-center services.
 - Service automatization and derived needs to improve transaction scores.
- **Neuromarketing**
 - Study of the impact of voice profiles and emotional states in client-agent transactions..
 - Tele-marketing, tele-assistance, neuromarketing.
 - Automatic monitoring of voice transactions.

“Handling this type of knowledge is of vital importance in neuromarketing and applications of the semantic web, in full alignment with the BRAIN Initiative promoted by NSF-NIH”

Market potential

- **Secure Access to Facilities and Services**
 - Transactions for identity verification in call centers (USA): costs around 20.000 M\$ yearly
 - Cost by transaction in terms of agents (30 s for transaction): 0.7 \$
 - Expected cost reduction: 0.2-0.4 \$
 - Annual transaction growth rate: 20%

Source: <http://www.redbooks.ibm.com>
- **Customer Research Management/Oriented Services**
 - Spain’s market numbers (2013): 1.468 M€ (+4%)
 - Employing 67.000 persons (+5%)
 - Agent /transaction costs: 2-4 €
 - Expected transaction hits: 3-5% (baseline in 2)%

Source: <http://www.networkworld.es>
- **Neuromarketing**
 - Current market numbers (USA): > 10.000 M\$
 - Annual transaction growth rate: 25%
 - Expected improvement by transaction: 200-300%

Source: <http://www.nature.com>

Competitive advantages

- Improvement in transaction hits up to a 200%, reduction in transaction attention times till 60%
- Implantation/adaptation costs under 50.000 € per center (for 100 posts)
- Easily implantable (ubiquitous, transparent, easily accepted by users compared to other systems, as facial, iris, or fingerprint)
- Highly reliable (false positive rates under 1 in 1 million accesses with false rejections under 1 in 100). Verification of emotional stress over a reliability of 99.45%.
- Grants juridical support against fraud, forgery or by the contracting part.
- Technology complementary to other existing ones.

References

- Hospital Universitario Gregorio Marañón, Hospital del Henares, Consejo Superior de Investigaciones Científicas, Universidad Autónoma de Madrid, Universidade de Porto, Ecole Superior de Telecom de Tunisia, Centro de Rehabilitación del Lenguaje de Madrid, Servicio de Criminalística de la Guardia Civil...

IPR

- Patent granted in Spain ES2364401
- Patent applied in USA 14/127,202

Development stage

- Concept
- R & D
- Lab Prototype
- Industrial Prototype
- Production

SIDEVAN contact (spin-off BioMetroSoft)

Pedro Gómez Vilda
e: pedro@fi.upm.es, pedro.gomezv@upm.es
w: <http://www.biometrosoft.com>

UPM contact

Innovation, Commercialization and
Entrepreneurship Area
Centre of Support for Technological Innovation
– UPM
e: innovacion.tecnologica@upm.es

UPM
spin-off

MINDZILLA. Mind your mind

Wireless medical grade EEG device that sends electrical signals from the brain to a unique algorithm designed to detect acute stress and reduce it

According to the World Health Organization stress will become the epidemic of the 21th century, a growing pathology mainly aggravated by our lifestyle 24/7 always available and our increasingly demanding jobs, that inevitably affect our health and quality of life. 40 million people are affected by stress in Europe, which entails a cost of € 20,000 million per year. This situation also produces a high cost to companies and governments diminishing their productivity. One out of four sick work leaves is related to stress. MINDZILLA is a medical grade device that controls stress levels offering an elegant and clinically reliable solution to this problem. For that purpose, we have developed a wireless electroencephalography (EEG) device along with a unique Software that can exploit all its technological potential. Therefore, creating a complete system based on Neurofeedback –conditioning real-time neural activity as it is recorded– that works for both diagnosis and treatment, getting rid of most common problems associated with standard solutions nowadays, and thus, enabling companies to increase their productivity by reducing the stress of their employees.

Technology solution supported by the Technical University of Madrid

Technology solution

MINDZILLA consists of a hardware device and a unique software, with the following features:

- **Hardware:** Wireless medical grade EEG device. It uses a new type of electrode –dry electrode– which ensures a quick and hygienic placement of the device and requires no gel or water to function. Being auto-amplified, no wires from the head of the subject to an external amplifier are needed, allowing complete mobility. The headset design where the sensors are placed achieves a great attachment and comfort for the user, being as easy to use as a cap. The location of the electrodes follows the international 10-20 standard system used in clinic and research. Moreover, the device has a Li-ion high capacity battery to prevent power cables and provide a long durability. Its bluetooth interface connects the device with tablets, smartphones and PCs .
- **Software:** The associated SW application is based on neurofeedback. Through a unique functional brain connectivity algorithm it detects brain stress levels of the subject and helps you reduce it.

“MINDZILLA records brain electrical waves to monitor and reduce stress levels”

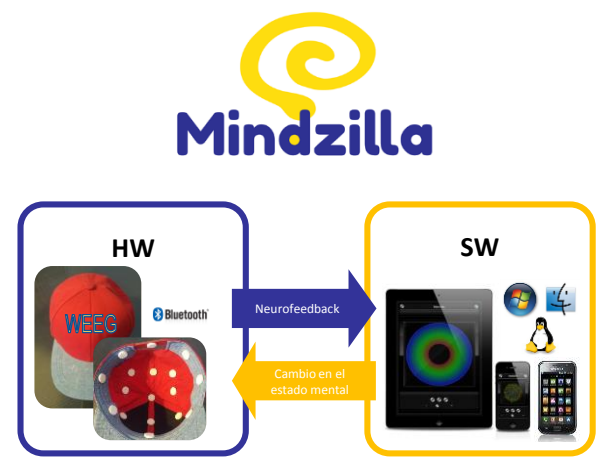

Areas of application

- ICT applied to health

Market demands

ICT applied to health

- In 2020, anxiety disorders, stress and depression will be the number one cause of disease in the developed world [World Health Organization, WHO].
- 60% of consultations in primary care are related to stress. Stress knows no age or sex [American Psychological Association, APA], [Sociedad Española para el Estudio de la Ansiedad y el Estrés, SEAS].
- Today there is a huge gap between what the health system provides and what people affected expect from it. Thus, they often have to ultimately use anti-stress balls, yoga or psychotherapies. However, 81% of patients fail treatments based on changes in lifestyle, due to willpower, confidence, time and stress itself [APA].
- Companies can not provide personalized tracking of their employees, which are subject to an increasingly "stressful" environment.

"In 2020, anxiety disorders, stress and depression will be the number one cause of disease in the developed world, according to a study carried last year by the World Health Organization"

Market potential

ICT applied to health

- 40 million people in Europe are affected by stress, which translates into a cost of € 20,000 million per year (due to absenteeism, decreased productivity, accidents, etc.) [Asociación Española de Especialistas en Medicina del Trabajo, AEEMT].
- Up to 80% of workers are more stressed than last year [APA], and one in four sick leave is related to stress [American Institute of Stress, AIS].
- Work stress affects in Spain to more than 40% of employees and nearly 50% of businesspeople suffer from Burnout [Instituto Nacional de Estadística, INE].
- Moreover, this disease also caused high rates of turnover and 50% of not justified absenteeism in companies [INE].

Competitive advantages

- Improves time efficiency: a conventional EEG placement requires 45 minutes, we reduce this time up to 80%.
- Mobility: full mobility with our wireless solution, in comparison to those using cables.
- Hygiene: uses dry electrodes, which allows greater hygiene and comfort for the user that when using gel.
- Medical Grade quality: and sensors positioned in the international 10-20 system used in clinic.
- Objectivity of results: current techniques for stress are subjective and difficult to monitor progress, we bring reliability and objectivity.
- Cost more than 50 times lower than the current research devices.

References

- Prize for best ideas at I actúa_COM Edition. Center for Open Middleware and Entrepreneurship Program UPM (2014).
- Honorable Mention for an Entrepreneurial Project. IDEA2, Madrid-MIT M+Vision Consortium (2013).
- Finalists at Venture Lab Accelerator. IE Business School Madrid (2013).
- Bioengineers doctors with 7 years of experience in engineering and neuroscience research, working at the Center for Biomedical Technology (CTB-UPM), which has 6 years in applied research projects, 2 companies created, 13 patents granted and a high involvement in the business sector since its creation in 2008.

Development stage

- Concept
- R & D
- Lab Prototype
- Industrial Prototype
- Production

MINDZILLA contact

Gerardo Gálvez; Guiomar Niso
e: weeg.mindzilla@gmail.com
Center for Biomedical Technology (CTB-UPM)
w: <http://www.mindzilla.es>

UPM contact

Innovation, Commercialization and
Entrepreneurship Area
Centre of Support for Technological Innovation –
UPM
e: innovacion.tecnologica@upm.es

Lynckia. Web Real Time Communications Solutions

Advanced based videoconferencing service that allows for easy multimedia communication through a Web Browser

Lynckia provides a service for web developers and enterprises that allows them to easily enhance their web pages with real-time multimedia communications. Leveraging technologies such as WebRTC, Lynckia offers a service and a technological solution that allows for seamless communications inside a browser.

Lynckia comprises both an open-source technology core and a cloud based service adaptable to the increasing demand.

All of this is the result of the efforts of researchers from the group of Internet of New Generation (Grupo de Internet de Nueva Generación - GING)) within the Higher Technical School of Telecommunications Engineering of the Technical University of Madrid (UPM)

Technology solution supported by the Technical University of Madrid

Technology solution

Lynckia provides multimedia rooms as a service. These rooms can be accessed via any WebRTC compatible browser. Clients can use the provided client-side API to integrate real-time communication (video, audio and data) seamlessly in their web pages.

Lynckia implements a fully compatible WebRTC stack that includes advanced services such as recording, streaming from IP-cameras.

The core of the technology has been released as open source software and already has an active community of developers that are deploying it in pre-production environments.

On top of that core, the full Lynckia solution offers a highly scalable service based on adapted algorithms.

Areas of application

- **ICT applied to:**
 - **Online meetings:** real-time collaboration and meetings.
 - **eHealth:** communicating patients and doctors, online patient monitoring.
 - **eLearning:** online real-time courses.
 - **Digital events:** streaming of multimedia events.

"Fully customizable WebRTC multimedia rooms for multiple participants with advanced features such as recording"

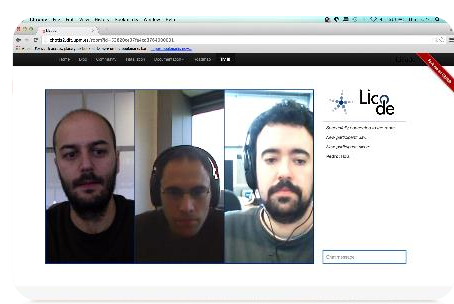

Lynckia



Market demands

▪ eHealth:

- Small physician practices can benefit from communicating directly with their patients with a simple tool within their own Web page.
- The ability to facilitate the access to the doctor is a great advantage for this small to medium groups.
- This videoconferencing needs to be secure and the ability to record the session for further study is also a must.

▪ eLearning:

- From private schools to MOOC (massive open online courses) platforms demand tools that provide the technology needed to give courses online without relying on external applications.
- By including the conference directly in their web page they can easily control the amount of courses given and the time each student is online.

▪ Digital Content:

- In today's Internet, many companies from a variety of sectors need to offer multimedia content in real time.
- The ability to offer this within a web browser and with the company's branding is very demanded.

“Lynckia offers a total customization of the communication solution for every need, from the type of communication to the branding in a clean an easy way”

Market potential

▪ eHealth

- The market will amount to 160.000M\$ in 2015 and that value will increase up to 12%-15% each year.

▪ eLearning

- It is a 56.200 M\$ a year market. This figure will double in 2015 and it includes traditional education, training in enterprises and Universities.
- It is estimated that in 2019 half of the total courses will be given via the Internet.
- Today, almost 4.6 million students are taking online courses.

▪ Online Meetings

- Video conferencing market will become a \$14 billion global industry by 2017 [Global Industry Analysts Inc.]

▪ Digital Content

- It is a market in a mature phase. A deeper analysis shows that, at this point, many enterprises need to offer online streaming content.

Competitive advantages

- Advanced videoconferencing capabilities such as recording, screen sharing and multiple participants conferences.
- Complete integration with the target web application. Lynckia allows the web owner to fully customize the look and feel of the communication.
- Software core backed by an active open source community.
- Scalability algorithms allow Lynckia to handle a growing amount of participants while being able to scale back down if needed.

References

- The core of Lynckia is already being used in pre-production commercial applications.
- Winner of VII Concurso Universitario de Software Libre 2013 (University Open-Source Competition) in Spain.
- Lynckia open-source core already has a community formed by more than 250 active developers.

Development stage

- Concept
- R & D
- Lab Prototype
- Industrial Prototype
- Production

Lynckia contact

Javier Cerviño, Pedro Rodríguez, Álvaro Alonso,
Joaquín Salvachúa
e: contact@lynckia.com
w: <http://www.lynckia.com>

UPM contact

Innovation, Commercialization and
Entrepreneurship Area
Centre of Support for Technological Innovation
– UPM
e: innovacion.tecnologica@upm.es

πContact. Mobile Solution for Smart Cities

It is a platform based on a mobile application which allows users to manage transport cards, make micropayments, and use other services related to Smartcities.

The initial application will be based on facilitating transport access card management using NFC, as well as unifying all the cards for the user. It will offer attractive indirect services to the user such as real time public transport information, delay alerts, and direct marketing.

Our proposal implies a huge betterment on comfort and offers new services to customers. Also, it would suppose a cost reduction for public and private transport companies as well as a sustainable development due to the card elimination.

Technology solution supported by the Technical University of Madrid

Technology solution

πContact tries to speed up service hiring and to unify different payment methods by taking advantage of the capabilities of last generation mobile devices.

The use of Contactless NFC technology, which is increasingly been used in the means of transport, favors the technological access to this market.

Using internet, users will be able to recharge their transport cards by adding them to their account and paying through a secure payment gateway.

Areas of application

- **Transport.**
- **ICT** oriented to network services and infrastructure.
- **ICT** oriented to transport mobility and intelligent systems.

"Multiplatform Contactless NFC for the use of Smart Cities means of transport"



Market demands

- There is a huge variety of travel cards forcing users to carry different cards for each enterprise they travel with.
- Each transport company develops or hires its own ticketing solution; however, its business is to provide a good transport service for its customers.
- There are different payment methods but they do not build confidence in users. At least, not enough to be used by everyone.
- Payment solutions that take advantage of mobile capabilities are sought. Nevertheless, they should be secure in order to be accepted by costumers.
- SmartCities are emerging and are creating new business opportunities, thanks to the data and the services that they can offer.



“It is usual to carry more than one card that allows to do payments, to be a VIP client or to access to specific services.”

Market potential

- The telecom networks API market will grow at a CAGR of 28 % between 2014 and 2019. [Market Research Reports]
- Specifically, in Comunidad de Madrid, the CRMT has an estimated annual sales volume of 16 millions of monthly season tickets and 400 millions of travels a year. [CRMT]
- In the coming years, the transport payment and mobile technology use annual growth rate will be 42%. [Gartner]
- Large companies are investing in this kind of technologies. For instance Indra, which has budgeted €4.3 millions for its project “MobiWallet”. [www.mobiwallet-project.eu]

Competitive advantages

- It is not necessary a physical card to make a payment as it is usual in other payment systems.
- With this technologic solution, it is not necessary a different SIM with physical security.
- Our solution is not focused in a particular sector; however, its technological development has been focused on one specific sector and then, the solution will be generalized to other sectors.
- There are multiple incoming sources that add value to the potential business model.

References

- Proof of concept developed for FI-WARE Hackathon that took place in Santander in 2013 (GeoMarketing) <http://youtu.be/--SrTEgvdgE>
- It is a part of Widgets Platform Evolution project, one of the Center for Open Middleware (COM) projects.

Development stage

- Concept
- R & D
- Lab Prototype
- Industrial Prototype
- Production

πContact contact

Santiago Blanco Ventas
santiago.blanco@centeropenmiddleware.com
Carlos Blanco Vallejo
carlos.blanco@centeropenmiddleware.com
Alejandro Fernández Carrera
alejand.fernandez.carrera@centeropenmidl
eware.com
Álvaro Arranz García
alvaro.arranz@centeropenmiddleware.com

UPM contact

Innovation, Commercialization and
Entrepreneurship Area
Centre of Support for Technological Innovation
– UPM
e: innovacion.tecnologica@upm.es

CUMULONIMBO BIGDATA PLATFORM. Analytics in a wink

The Power of a Wink: while you wink we answer your queries over terabytes of data, process millions of transactions and correlate millions of events

An ultra-scalable transactional database with On Line Analytical Processing (OLAP) capabilities able to query TBs of data in seconds while processing million transactions per second and correlating millions of events per second. CumuloNimbo BigData platform is a scale-out solution for OLTP, OLAP and CEP where you store your data once therefore, avoiding costly ETLs and its associated headaches. It also provides transparent scalability for transactional processing on commodity hardware enabling to scale the database in public or private clouds avoiding sharding. The solution is built on top of NoSQL technology, Hadoop HDFS and HBase providing also full ACID transactions for HBase and enabling to combine SQL and NoSQL as needed. The integration with the Hadoop ecosystem enables to exploit existing open source products from this ecosystem such as R for predictive analysis and Mahout for large scale machine learning.

Technology solution supported by the Technical University of Madrid

Technology solution

It is the first solution able to scale transactions providing full ACID transactions with full SQL support and providing standard interfaces (JDBC, ODBC) in a fully transparent way to applications (your data management application will be scaled without touching a single comma) base on commodity hardware and amenable to be run in public and private clouds.

The platform also incorporates a scale-out parallel query processing to provide OLAP support and perform analytical queries over TBs of data in seconds.

Finally, the platform also integrates a scale-out parallel complex event processing engine able to correlate millions of events per second.

Areas of application

- **Information & Communication Technologies (ICT):** transactional databases (OLTP); analytical data warehouses (OLAP); complex event processing (CEP); SQL and NoSQL; Public & Private Clouds; Database as a Service; Platform as a Service.

In a wink, we answer your queries over TBs of data, process millions of transactions updating your data, and correlate millions of events with your data



Market demands

▪ Scalable Databases in Public & Private Clouds

- Current cloud databases do not scale. The way to overcome this gap is by means of sharding, splitting the database into fragments. However, the transactional ACID properties are lost extremely complicating the application requiring very costly changes.

▪ Avoiding copying data through ETLs

- Current database systems are specialized on different tasks. Transactional databases are used for the production database due to their ability to support updates in a consistent manner. Data warehouses are used for getting online responses to heavy analytical queries. However, this approach requires to architect, develop and plan a process to copy from the production database to the data warehouse, the so-called ETL process. It is estimated that ETLs are 75-80% of business analytics.

▪ Operational Intelligence and New Applications

- Many companies have the same recurrent question: how to monitor their business processes to react faster to opportunities and threats. Current IT infrastructure results in reaction times of days.

“Scale your Database Without Limits Avoiding Sharding and its Associated High Cost”

“Perform Analytical Queries on your Production Transactional DB Avoiding Costly ETLs “

“Correlate Millions of Events per Second”

Market potential

▪ Platform as a Service Market

- 2016 Forecast : 15 \$Billion [Forrester Research - 2009]
- CAGR 22-48% depending on the area

▪ NoSQL Market

- 2013-2018 Forecast: \$14 Billion, CAGR 21% [MarketResearchMedia – Oct. 2012].

▪ Business Intelligence & Analytics Market

- 2011: \$12 Billion. 16.4% more than 2010 [Gartner - 2012].

▪ Big Data Market

- 2016 Forecast: \$6 Billion. [Gartner - 2012].

Competitive advantages

- Scalable transactions for public & private clouds providing full ACID transactions & full SQL transparently to applications: Avoids sharding and 100% of its cost.
- OLTP+OLAP on a single database: Avoids the costs of ETLs that are estimated to be 75-80% of the overall costs of analytics. Enables real-time business intelligence.
- Correlate massive events with your data: Enabling operational intelligence with OLTP+CEP+OLAP
- Based on commodity hardware and scaling out: Avoids the costs of appliances, usable in clouds.
- Based on Hadoop ecosystem and interoperable with ecosystem tools such as R, Mahout, Flume, etc.

References

- A large international bank is already evaluating the adoption of the platform.
- The co-founders have led 5 European projects and obtained and managed 6+ Million Euro in the last 5 years. They have been intensively researching scalable data management during the last 15 years.

IPR

Two patents applied in USA, protecting all the core innovations:

- USPTO 61/356,353 (scalable transactions)
- USPTO 61/561/508 (parallel query processing)

Development stage

- Concept
- R & D
- Lab Prototype
- Industrial Prototype
- Production

CumuloNimbo BigData Platform contact

Ricardo Jiménez-Peris
Marta Patiño-Martínez
Distributed Systems Lab (LSD)
Universidad Politécnica de Madrid
e: {rjimenez,mpatino}@fi.upm.es

UPM contact

Innovation, Commercialization and
Entrepreneurship Area
Centre of Support for Technological Innovation
– UPM
e: innovacion.tecnologica@upm.es

VoteSim. Maximize your clients' social welfare

Platform for developing and evaluating: voting, recommendation, personalization, and gathering information services into intelligent environments

Researchers of the research Group on Intelligent Systems (GSI) at the Technical University of Madrid in collaboration with the Intelligent Systems and Telematics Group of the University of Murcia have developed the VoteSim platform. This platform allows the development of recommendation and votation systems in the scope of intelligent spaces.

VoteSim allows quantifying and optimizing user satisfaction and other relevant factors such as the maximum waiting time to access personalized services. For this purpose, VoteSim combines: an editor for modeling ad hoc smart spaces, agent-based social simulation to model a society of artificial users/clients, recommendation systems based on machine learning techniques, and a large number of voting algorithms to maximize social welfare and customize shared services.

Technology solution supported by the Technical University of Madrid

Technology solution

Ambient Intelligence (Aml) focuses on adapting to people's needs and particular situations. For example, an intelligent hotel may offer a number of configurable and shareable services: screening rooms, decoration based on dynamic decorative panels, dance clubs, heated swimming pools, and etcetera.

In these cases, the system has to decide how to configure these services and this decision involves trying to make customers as happy as possible while avoiding that some customers' preferences are constantly denied in favour of the common good. VoteSim allows developers to design and conduct quantifiable evaluations of recommendation systems and Aml services which have to reach consensus trying to maximize users' satisfaction.

"VoteSim includes numerous ready-to-use social choice and recommendation algorithms. This makes an easy and intuitive task the development of intelligence services to reach consensus and personalize configurations. Moreover, these services can be evaluated in 3D simulations."

Areas of application

- ICT applied to intelligent environments

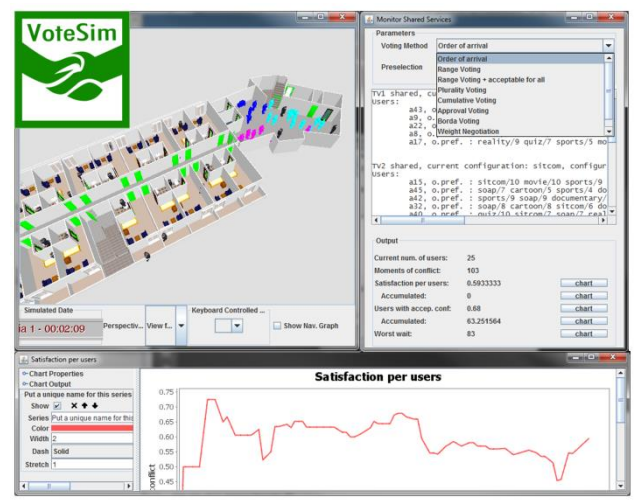

Market demands

- Intelligent Environments (IEs) use networked computing technology to create environments that are sensitive and responsive to the presence of people.
- Ones of the most demanded features in smart spaces are customization services, recommenders, and gathering users information.
- Globally, there were nearly 22 million wearable devices in 2013 generating 1.7 petabytes of monthly traffic [Cisco Visual Networking Index., 2013]

“Ones of the most demanded needs in smart spaces are: services customization, provide recommenders, and gathering clients’ information. VoteSim can develop systems to encompass these needs.”

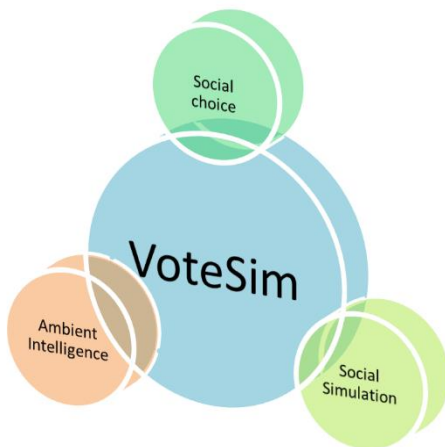

Market potential

- By 2020 the market of intelligent spaces could be worth between 22 billion and 50 billion dollars and made up of some 16 billion connected devices [Arthur D. Little Report]
- High penetration of smartphones, chosen by many users as their personal electronic device. In fact, the number of smartphones will grow from 1,500 million in 2011 to 2,000 million in 2015.
- By the end of 2014, the number of mobile-connected devices will exceed the number of people on earth, and by 2018 there will be nearly 1.4 mobile devices per capita. There will be over 10 billion mobile-connected devices by 2018, exceeding the world’s population at that time (7.6billion) [Cisco Visual Networking Index., 2013].

Competitive advantages

- VoteSim can easily include customization services by aggregating users’ preferences with a series of voting algorithms such as: plurality, Borda, range, approval, cumulative, etcetera.
- The only simulator that implements various voting systems and recommendation services considered from the perspective of intelligent spaces. It also includes innovative algorithms specially designed to maximize user satisfaction in shared spaces.
- Unlike the political case, users or clients can choose from several services in shared spaces. VoteSim can automatically conduct an intelligent data analysis of the feedback obtained after voting and, based on this analysis, recommending the most suitable services for each client.
- Depending on the voting or recommending service used, different clients’ data are requested by the system and gathered for further analysis.

References

- VoteSim has been used in THOFU - *Technologies for the Hotel of the Future*, a R&D project which focuses on new tourism concepts and the way exclusive and innovative hotel services could be delivered.
- VoteSim video: goo.gl/82Us7f [Us7E](https://www.youtube.com/watch?v=Us7E)

IPR

- Code under GNU General Public License v3.0
- Registration of copyright [M-2616-2014]

Development stage

- Concept
- Industrial Prototype
- R & D
- Production
- Lab Prototype

VoteSim contact

Emilio Serrano , Carlos A. Iglesias, Mercedes Garijo, Juan A. Botía
e: cif@gsi.dit.upm.es
w: <http://www.gsi.dit.upm.es/>

UPM contact

Innovation, Commercialization and Entrepreneurship Area
Centre of Support for Technological Innovation – UPM
e: innovacion.tecnologica@upm.es

EscapeSim. Beyond the emergency drills

Platform for developing and evaluating emergency management services into intelligent environments

Researchers of the research Group on Intelligent Systems (GSI) at the Technical University of Madrid in collaboration with the Intelligent Systems and Telematics Group of the University of Murcia have developed the EscapeSim platform. This platform allows the development and evaluation of open emergency management services into intelligent environments.

EscapeSim allow developers to (1) define emergency scenarios; (2) use predefined emergency management strategies; (3) implement new strategies; (4) build user profiles, such as handicapped or emergency managers; and, (5) conduct an evaluation of emergency plans through a batch of simulations. After this, the leap from an agent-based social simulation to a multi-agent system implementing the emergency plan is straightforward.

Technology solution supported by the Technical University of Madrid

Technology solution

One of the most promising fields for Ambient Intelligence (Aml) is the implementation of intelligent emergency plans. By using Aml, it is possible to improve the collaboration and coordination strategy of response efforts in emergency situations.

Designing and testing emergency plans in intelligent environments is a must. But drills are expensive and cannot cover the great variety of possible situations. EscapeSim employs Agent based social simulation as a technology to provide developers with a decision support system in this scope. An emergency plan can be easily implemented and evaluated in millions of scenarios at the expense of little time. Moreover, after pure simulated tests, participatory simulations where real users interact with the simulation through mobile devices such as smartphones are possible.

Areas of application

- ICT applied to intelligent environments

"The leap from an agent-based social simulation to a multi-agent system implementing the emergency plan is straightforward"

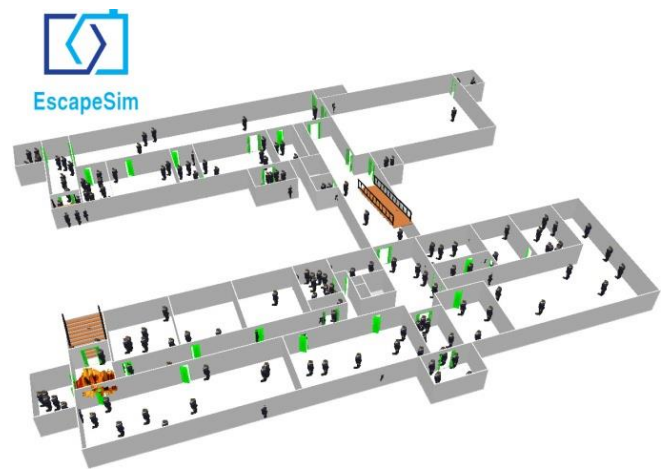

Market demands

- Intelligent Environments (IEs) use networked computing technology to create environments that are sensitive and responsive to the presence of people.
- Ones of the most demanded features in smart spaces are emergency management services.
- Globally, there were nearly 22 million wearable devices in 2013 generating 1.7 petabytes of monthly traffic. [Cisco Visual Networking Index., 2013]

“Several recent catastrophes, such as the Madrid Arena and the Brazilian Santa Maria, have demonstrated the necessity of improving emergency plan strategies”



Market potential

- Emergency management and incident management market will worth \$93.39 Billion by 2018 [Market Forecasts and Analysis, 2013].
- By 2020 the market of intelligent spaces could be worth between 22 billion and 50 billion dollars and made up of some 16 billion connected devices [Arthur D. Little Report]
- High penetration of smartphones, chosen by many users as their personal electronic device. In fact, the number of smartphones will grow from 1,500 million in 2011 to 2,000 million in 2015.
- By the end of 2014, the number of mobile-connected devices will exceed the number of people on earth, and by 2018 there will be nearly 1.4 mobile devices per capita. There will be over 10 billion mobile-connected devices by 2018, exceeding the world's population at that time (7.6billion) [Cisco Visual Networking Index., 2013].

Competitive advantages

- Emergency simulators are usually “closed” and for specific services, i.e. they cannot be parameterized to adapt them to other cases beyond the studied case.
- EscapeSim uses semantic web technologies as a powerful tool to reuse, extend, and combine different simulation components.
- The cooperative development is enhanced since terms and relationships can intuitively be shared by emergency experts, modellers and developers.
- Participatory simulations where real users can interact with the virtual environments through smartphones are also possible.
- Last but not least, using ontological domain knowledge as base for simulations, developers can automatically check the relations and dependences between the simulated models and obtain guidelines in their implementation.

References

- Escape has been used in THOFU - *Technologies for the Hotel of the Future*, a R&D project which focuses on new tourism concepts and the way exclusive and innovative hotel services could be delivered.
- EscapeSim video: goo.gl/b9JluM

IPR

- Code under GNU General Public License v3.0
- Registration of copyright [M-2615-2014]

Development stage

- Concept
- Industrial Prototype
- R & D
- Production
- Lab Prototype

EscapeSim contact

Emilio Serrano, Geovanny Poveda, Carlos A. Iglesias, Mercedes Garijo, Juan A. Botía
e: cif@gsi.dit.upm.es
w: <http://www.gsi.dit.upm.es/>

UPM contact

Innovation, Commercialization and Entrepreneurship Area
Centre of Support for Technological Innovation – UPM
e: innovacion.tecnologica@upm.es

FlowData. The MP3 of databases

FlowData takes a massive database and, out of it, generates a virtual one that is much smaller and that contains the essential information

FlowData represents a new paradigm in the treatment of multidimensional databases. There is no need for a priori statistical hypothesis. Data patterns are obtained as they are. The technology has been extensively tested in projects for the aerospace sector. Preliminary tests in data analysis (no aerospace) gave very promising results. The first FlowData application would be for more sophisticated risk engines for credit card fraud detection

Technology solution supported by the Technical University of Madrid

Technology solution

FlowData represents a new paradigm in the treatment of multidimensional databases.

FlowData relies on tensor analysis techniques (High Order Singular Value Decomposition and Proper Orthogonal Decomposition) instead of statistical methods.

The main advantage is that there is no need to formulate a priori hypothesis regarding the statistical distributions of data. Global patterns are obtained as they are.

FlowData has been preliminarily tested in the problem of bank deposits distribution in the USA as a function of state, county and year.

Results are very promising both in terms of size reduction and reconstruction errors

Areas of application

- Finance, banking, and insurance
- Security

"FlowData generates small virtual databases that replicate the original ones while keeping the essential information"

FlowData treats a picture like a database



Original



Virtual

Market demands

- In the financial, banking and insurance sectors the use of real-time analytics applications to help in decision making is becoming widespread.
- These applications need to interact in real time with massive databases and this fact limits the algorithmic sophistication of the application itself.
- Being able to work with virtual (smaller) databases allows for the use of much more sophisticated algorithms and, therefore, for a more reliable decision making process.
- For example, in a practical application of credit card fraud detection FlowData would make it possible for its customer (a bank, for instance) to run in real time much more powerful algorithms to decide whether a certain transaction in an electronic point of sale is either blocked or allowed.
- In the security sector many situations exist that present strong similarities with what has been described above.

“Decision making in complex environments is becoming more and more sophisticated; FlowData facilitates this sophistication”

Market potential

- The global business intelligence market is estimated to reach \$20.81 billion in 2018 from \$13.98 billion in 2013, at an estimated Compound Annual Growth Rate (CAGR) of 8.28% during the same period of five years. The North American market captures a major share of 49% of the global BI market [Research and Markets, 2013].
- The market for big data will reach \$16.1 billion in 2014, growing 6 times faster than the overall IT market [IDC, 2013].
- Cloud infrastructure will be the fastest-growing sub-segment of the big data market, with a 2013-2017 CAGR of close to 50% [IDC, 2013].

Competitive advantages

- It has been proven extensively in engineering problems with industrial customers.
- Preliminary tests in environments other than engineering have been very promising.
- Customers gain an easier and much more efficient operation of their risks engines so they can make sounder decisions.
- The technology is transversal and can be applied to different sectors that deal with massive databases.

“FlowData is the ideal partner for multinational corporations that continuously make decisions in complex environments. Next steps will aim to penetrate markets other than finance and banking that involve simultaneous data analysis and decision making”

References

- Five PhD Thesis completed in the frame of this technology development.
- Proven application to database analysis in the aerospace sector.

Development stage

- Concept
- R & D
- Lab Prototype
- Industrial Prototype
- Production

Flow Data contact

Ángel Velázquez
e: angel.velazquez@upm.es

UPM contact

Innovation, Commercialization and
Entrepreneurship Area
Centre of Support for Technological Innovation –
UPM
e: innovacion.tecnologica@upm.es

TwitterSimulator. Plan your marketing strategies

Framework for simulation of the social network to evaluate the behaviour of the users under given conditions.

Researchers of the research Group on Intelligent Systems (GSI) of the Technical University of Madrid have developed the TwitterSimulator framework. This simulation framework allows to evaluate the behavior of different types of users, and potential clients of a company, analysing how they react when different external stimulus come to them through the social network.

TwitterSimulator allows developers to (1) define user behaviors; (2) use real user networks obtained from the social network; (3) plan marketing strategies emulating the events that users receive through the social network; (4) simulate how that users react; and (5) evaluate the different strategies to get the more reliable one.

Technology solution supported by the Technical University of Madrid

Technology solution

The social networking services has become one of the most direct communication channel with the final client of almost any company.

This behaviour has changed the traditional marketing strategies since the client is more reachable figure that is always online through its smartphone and/or computer.

TwitterSimulator offers an approach to evaluate different marketing strategies with different types of clients with different behaviours, providing a way to analyse and compare them.

"This simulation framework allows to evaluate the behavior of different types of users, and potential clients of a company"

Areas of application

- IT and Communications applied to Digital Contents.

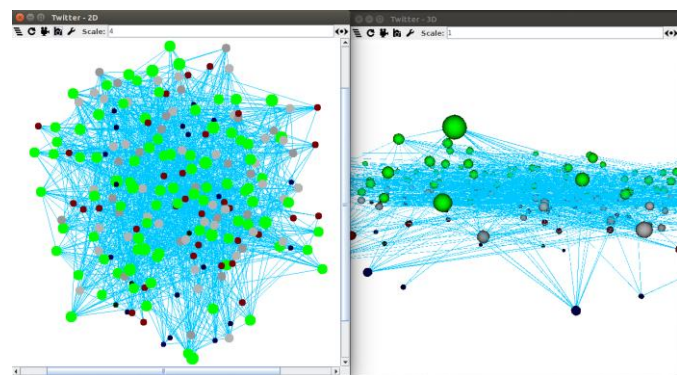

Market demands

- A 89% of Social Media marketers want to answered the following question: “What are the best ways to engage my audience with social media?” and a 83% of them want to know “how they can create a social strategy” [2014 Social Media Marketing Industry Report, Michael A. Stelzner, Social Media Examiner].
- A majority of marketers (67%) will increase their activities on Twitter, up from 64% in 2013 [2014 Social Media Marketing Industry Report, Michael A. Stelzner, Social Media Examiner].

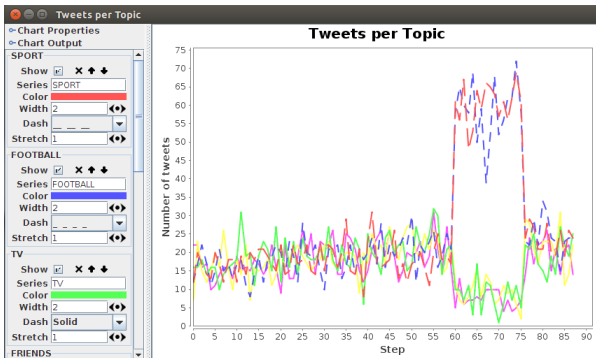

“Social networking services has become one of the most direct communication channel with the final client.”

Market potential

- Social Media-based Marketing is increasing in the last years.
- A significant 92% of marketers indicate that social media is important for their business [2014 Social Media Marketing Industry Report, Michael A. Stelzner, Social Media Examiner].
- Furthermore, Twitter has been ranked the fastest growing social platform in the world [Forbes & GlobalWebIndex, 2013].
- The 80% of marketers use Twitter as social media platform for advertisement [Statista.com]
- The 72% of Twitter followers of a brand that are more likely to purchase a product from that brand [ExpandeDrablings.com].
- Globally, we are talking about \$405,500,000 of revenue for Twitter Company only from advertising in 2013 [StatisticBrain.com, 2014].

Competitive advantages

- The growth of social media services has led to the apparition of many companies that simulate situations of interest to third parties, but these companies do not offer the source code of their simulators.
- TwitterSimulator offers an open source framework based on a multi-agent approach to simulate each user independently of the others.
- While other social simulators are focused only on the social network itself, TwitterSimulator allows to generate external events, such as a football match, during a given period of time in the simulation, providing a rich way to add realistic conditions to the simulation environment.

References

- Source code of the framework is available in the next Github repository:
<https://github.com/gsi-upm/TwitterSimulator>

IPR

- Code under GNU General Public License v2.0
- Registration of copyright [M-002600/2014]

Development stage

- Concept
- R & D
- Lab Prototype
- Industrial Prototype
- Production

TwitterSimulator contact

Álvaro Carrera Barroso, Carlos Ángel Iglesias Fernández
e: cif@gsi.dit.upm.es
w: <http://www.gsi.dit.upm.es>

UPM contact

Innovation, Commercialization and Entrepreneurship Area
Centre of Support for Technological Innovation – UPM
e: innovacion.tecnologica@upm.es

SHANKS. Beyond an interactive network simulator

Framework for simulation of heterogeneous telecommunication networks into a multi-agent environment.

Researchers of the research Group on Intelligent Systems (GSI) of the Technical University of Madrid have developed the SHANKS framework. In contrast with other existing alternatives, this framework allows to develop a simulation environment in which agents can interact easily with the network, their devices and their configuration. Thus, SHANKS provides an interactive approach to develop testbeds of the Future Internet autonomous networks.

SHANKS allows developers to (1) define heterogeneous network scenarios; (2) use multi-agent approach to apply network management techniques; (3) simulate behaviours of the final users; and (4) evaluate different strategies of management for the simulated networks under a set of given conditions.

Technology solution supported by the Technical University of Madrid

Technology solution

Network Management is one of the most important tasks for telecommunication operator companies. Traditionally, this process has been carried out by humans and software systems that work in a cooperative way. But the size and complexity of the networks is increasing exponentially since a recent past. Thus, network operators are very interested in the full automation of some management tasks, such as fault diagnosis and recovery.

SHANKS offers an interactive approach to be able to manage the simulated network and its users as it was real, providing a way to analyse and compare different techniques that can be applied in the real-life scenarios.

Moreover, the multi-agent approach allows to use intelligent techniques for some management tasks.

Areas of application

- IT and Communications applied to Network Services and Infrastructure (SW, networks, Future Internet...)

"SHANKS provides an interactive approach to develop testbeds of the Future Internet autonomous networks"

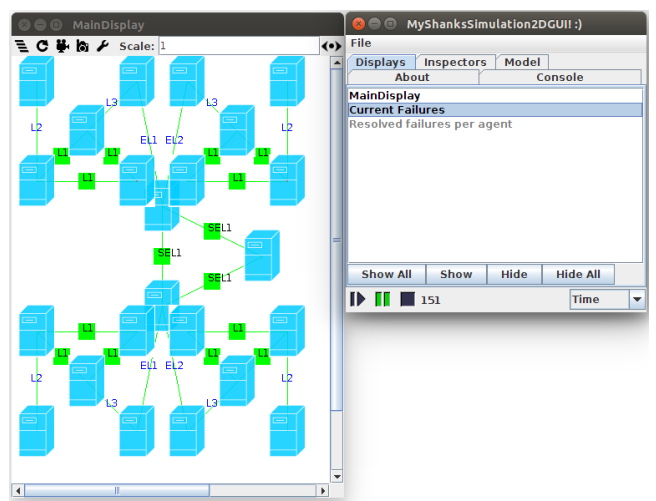

Market demands

IT Network Management

- The full automation for management tasks in telecommunication networks is highly desirable as the size and the complexity of the network increase every day [Cisco Systems Inc. 2013 Annual Report].
- The growing numbers of different services and the different behaviours of the final users requires the network adapts its configuration depending of external conditions. Thus, Innovative approaches for Future Internet networks must be explored using simulation and virtualisation tools.

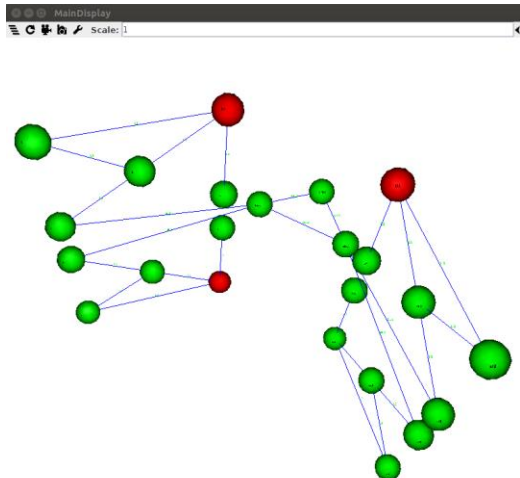

"Network operators are very interested in the full automation of some management tasks"

Market potential

Telecommunication Operator Companies

- Network Management Systems generated \$4.6 billion in revenue during 2013, up 2% from \$4.5 billion in 2012 [AnalysisMason.com].
- The Network Management Market worth \$6.35 Billion by 2018 [MarketsAndMarkets.com].
- Shanks can be applied to test the use of agent paradigm in Software-Defined Networks (SDN), which will have a \$2 billion market by 2016, up from \$200 million in 2013 [SDNCentral.com]
- The power of abstraction offered by SDN provides a level of flexibility never known before in network management systems. The possibility of configuration in real time makes SDN as one of the most reliable technologies for network management of Future Internet [SDN and the Future of Service Provider Networks, Fujitsu 2013].

Competitive advantages

- Network simulators are usually configured with a set of parameters that cannot be modified in simulation time.
- SHANKS offers an interactive framework that allows developers to modify the configuration and, consequently, the behaviour of the network.
- The application of a multi-agent approach allows the use of intelligent approaches for the management of complex and heterogeneous networks.
- While, other network simulators are focused only on the network, SHANKS supports the simulation of the consumer's behaviour which provides more realistic results.

References

- Source code of the framework is available in the next Github repository: <https://github.com/gsi-upm/Shanks>

IPR

- Code under GNU General Public License v2.0
- Registration of copyright [M-002597/2014]

Development stage

- Concept
- R & D
- Lab Prototype
- Industrial Prototype
- Production

SHANKS contact

Álvaro Carrera Barroso, Carlos Ángel Iglesias Fernández
e: cif@gsi.dit.upm.es
w: <http://www.gsi.dit.upm.es>

UPM contact

Innovation, Commercialization and Entrepreneurship Area
Centre of Support for Technological Innovation – UPM
e: innovacion.tecnologica@upm.es



Transport, Security & Space

Transport, Security & Space

Solutions shown here include those which focus on developing safer, greener and smarter transport systems. Also, space related technologies such as satellite navigation, GIS, etc. and technologies that increase security of citizens, society in general, infrastructures and services.

INSIA dynamometric wheel

[Link](#)

Innovative technology for improving vehicle safety

BIO-stress

[Link](#)

Real-time stress detection system

In-Air Signature

[Link](#)

Security verification on smartphones

ESCAM

[Link](#)

An alternative to mechanical scanning

BETsMA

[Link](#)

Mitigating space debris with just one click

Structural Fiber Sensing

[Link](#)

Efficient maintenance of smart structures

Silfrared

[Link](#)

The dark side of light

VecMan – Vectorial Magnetic Nozzle

[Link](#)

Simple solution to control the direction of the thrust vector in space plasma thrusters

AFeNSat

[Link](#)

Revolutionary technology for the next generation of satellite communications

Transport, Security & Space

AUTOSTEERING

Equipment for automatically controlling the steering of a vehicle

[Link](#)

Check Transport, Security & Space UPM technologies marketplace

[Website](#)

INSIA Dynamometric wheel. Produce safer and more reliable, efficient and durable vehicles.

A wheel that measures the forces and moments generated in the tire-road contact area to improve the safety of vehicles.

INSIA Dynamometric wheels measure the forces and moments generated at the tire-road contact area. For that purpose, the wheels of the vehicle are directly instrumented with strain gauges. As the vehicle keeps its original wheels, its dynamic behavior is not altered. It is estimated that the cost of the components that are necessary to produce these dynamometric wheels is almost two orders of magnitude lower than the price of a commercial dynamometric wheel.

This makes affordable to run a car or a truck with a full set of dynamometric wheels. Now, it is possible to use dynamometric wheels for other applications that used to be economically unfeasible, such as for example, using them to provide information to the active safety systems of the vehicle.

Technology solution supported by the Technical University of Madrid

Technology solution

In order to fully understand the dynamic behavior of the vehicle, accurate experimental data of the tire-road contact forces and moments are needed. INSIA Dynamometric wheels measure these forces and moments by mounting in a very special way a set of strain gauges on the vehicle's wheels. The strain gauges are grouped in at least three concentric circumferences and in equidistant radial lines. The strain signals of the same circumference are linearly combined to obtain at least two new signals that only depend on the contact forces and moments. The influence of the angle rotated by the wheel, the temperature or the centrifugal forces is eliminated in these new signals by using a technique based on the elimination of Fourier harmonics. The contact forces and moments are obtained from these new signals by solving two systems of linear equations with three unknowns each. An onboard electronic system including telemetry is being developed in the University of La Coruña.

"Now, it is possible to use dynamometric wheels in Research Centres and Universities, and for other applications that used to be economically unfeasible"

Areas of application

- Modeling tires and vehicles.
- Produce safer and more reliable, efficient, and durable components.
- Improve the performance of the active safety systems of the vehicle (ABS and ESP).
- Research and education.



Market demands

- **Universities/Research Centers:** Universities and research centers can use dynamometric wheels to model vehicles and tires. The objective of tire modeling is to find mathematical expressions related to the forces and torques appearing in the tire-road contact with different variables. In order to verify the quality of these formulated mathematical models and verify whether they adjust to reality or not, obtaining experimentally the contact forces and moments becomes necessary.
- **Tire and automotive component manufacturers:** Tire manufacturers need to compare the forces generated and transmitted by different tire models to determine the best alternative for a certain application. In addition, the design and validation of automobile components requires a detailed knowledge of the forces and the moments acting on the tire-road contact, which allows vehicle designers to produce safer and more reliable, efficient, and durable components.
- **Automobile companies:** The performance of the active safety systems of the vehicle, such as ABS and ESP, can be significantly improved if more detailed information in real time of the forces applied to the tire-road contact could be obtained. This information, which can be used to determine possible dangerous situations, can be obtained by using dynamometric wheels. Therefore, safer vehicles that include dynamometric wheels can be produced.

“INSIA dynamometric wheels can be used to produce safer and more reliable, efficient and durable vehicles”

Market potential

- If the automotive industry were a country, it would be the world's sixth largest economy [OICA, 2005]:
 - No. of manufactured vehicles in a year: 66 million.
 - Turnover: 2,000 billion euros.
 - R&D investment: 85 billion euros.
- More than the 80% of the vehicles include sensors. 60-70 individual sensors can be found in a single vehicle [Bosch, 2009].
- The potential of using dynamometric wheels as an information source for ABS and ESP is very high:
 - Only Bosch produces 65,000 units of ABS daily [Fedit, 2010].
 - All vehicles produced in the UE since 2011 must have ESP.

Competitive advantages

- Commercial dynamometric wheels have different inertial properties than the original wheels of the vehicle, and can therefore alter their dynamic behavior. INSIA dynamometric wheels are produced by directly instrumenting the vehicle's wheels, so its dynamic behavior remains unaltered.
- Commercial dynamometric wheels have a very high cost, much higher than the price of the whole vehicle (approximately 100,000 Euros for cars and 200,000 Euros for trucks) and are prohibitive for most potential customers such as universities and small research centers. The estimated cost to produce these INSIA dynamometric wheels is approximately of 2,000 Euros, which makes affordable to run a car with four dynamometric wheels.
- Errors below 2% have been obtained in the static experimental tests.

References

- **Javier García de Jalón:** Professor of the Technical University of Madrid. IFToMM Award of Merit and ASME D'Alembert Award in Washington, USA. 2011
- **M^a Dolores Gutiérrez-López:** PhD Student in Mechanical Engineering. Industrial Engineer and Bachelor in Business Administration. University Education National Award.

IPR

- Patent granted in Spain ES2363400.
- International patent applied via PCT PCT/ES2012/000044 WO2012/117129.
- Patent applied in US 14/002,858
- European Patent applied via EPO EP12751901.5

Development stage

- Concept
- R & D
- Lab Prototype
- Industrial Prototype
- Production

INSIA dynamometric wheel contact

Javier García de Jalón and María Dolores Gutiérrez

E-mail: javier.garciadejalon@upm.es;
md.gutierrez@upm.es

UPM contact

Innovation, Commercialization and Entrepreneurship Area

Centre of Support for Technological Innovation – UPM

E-mail: innovacion.tecnologica@upm.es

BIO-STRESS. Real-time stress detection system

Low computational cost software for detecting the stress level of an individual in real time

The Group of Biometrics, Biosignals and Security (GB2S) within Centro de Domótica Integral (CeDInt) from Technical University of Madrid (UPM) has developed a stress-detection system to provide information on the state of mind of an individual for real-time applications and designing a low computational cost implementation. This detection is of great interest for applications requiring a good preparation in high stress demand situations (such as training special forces) or a complement to existing security (as in the case of biometrics, road safety or automation). The method requires only two physiological signals (heart rate and galvanic skin response) and just easily integrated and noninvasive sensors, resulting in wide acceptance and usability by the individual. The stress-detection accuracy obtained is 99%.

Technology solution supported by the Technical University of Madrid

Technology solution

The software provides a solution for stress detection based on two physiological signals (heart rate and skin conductance), especially geared for real-time environments, which requires knowing the individual's mood instantly.

It must be noted that the main difference is based on modeling the behavior of both physiological signals in different degrees of stress by employing fuzzy logic, which allows a maximum adaptation to each subject.

Moreover, its low computational cost and the ability to integrate the required sensors represent a low invasiveness, resulting in increased acceptance and usability.

Areas of application

- **Security:** training special forces (police, fire, military) to improve its performance in stressful environments.
- **Transport:** drowsiness detector driving.
- **Health:** monitoring elderly (falls, accidents).

"The method achieves stress-detection accuracy rates close to 99%, representing a 10% improvement compared to previous solutions and using just 2 human physiological parameters"

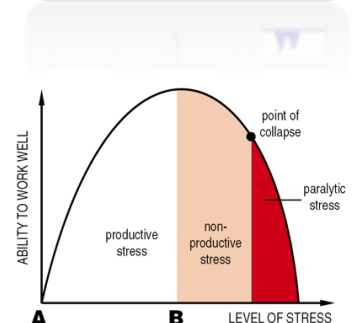
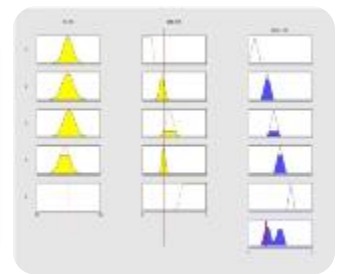

Market demands

▪ Security

- Training special forces (police, fire, military) to act properly under stressful situations.
- Soldier monitoring to quantify resilience and maximize the effective action in combat.

▪ Transport

- In Spain, 16% of road accidents are caused by falling asleep while driving.
- Monitoring the attention of a driver in a non invasive way is one of the main goals in research related to road safety.
- Also, excessive stress while driving leads to traffic accidents.

▪ Health

- Falls and other common accidents are a major cause of death in elderly people.
- The social phenomenon called Silver Tsunami provides current governments' inability to deal with proactive monitoring of elders.

"An accurate and instant stress detection could detect when a person falls asleep while driving (no stress), when an older person falls (nervousness) or if a soldier needs reinforcements for being unable to face combat missions (high stress) "

Market potential

▪ Security

- Post-traumatic stress disorder treatment could cost USA Army up to \$1.5 million over the lifetime of a soldier. [Los Angeles Times]

▪ Transport

- Accidents caused by over-fatigued drivers in the U.S. represent a total of 12. 500 \$ millions annually. [Drowsy Driving]
- In 2011, 238 people died from falling asleep while driving in Spain. [Dirección General de Tráfico]

▪ Health

- In 2020, direct and indirect costs related to falls and accidents of elderly will account almost 55 billion dollars a year. [CVIDA]
- In 2020, there will be a total of 10.1 million disabled elderly, which will require a total of 2.5 million dedicated nursing [Elder Parent Help].

Competitive advantages

- Low invasiveness in acquiring physiological signals, resulting in higher integrability of sensors and user acceptability.
- Continuous monitoring by quantifying the stress level of the individual.
- High accuracy in the stress detection (99.5%).
- Customized and adaptative stress detection according to individual's mood over time.
- Stress detection method based on fuzzy logic with low computational cost and processing times in milliseconds.

References

- Wide research background and business collaboration.
- High research interest for this technology solution both nationally and internationally.
- Clear focus on innovation and commercialization of research by the group.

IPR

- Patent applied in USA US20130137996
- Software registration M-003315/2012

Development stage

- Concept
- R&D
- Lab Prototype
- Industrial prototype
- Production

Bio-stress contact

Carmen Sánchez Ávila
e: csa@cedint.upm.es
w: <http://www.gb2s.es>

UPM contact

Innovation, Commercialization and
Entrepreneurship Area
Centre of Support for Technological Innovation
– UPM
e: innovacion.tecnologica@upm.es

IN-AIR SIGNATURE. Security verification on smartphones

Software based solution to verify people through performing an identification hand movement holding a Smartphone

Biometrics, Biosignal and Security Group (GB2S), located within the integrated Domotics Center (CeDInt) of the Technological University of Madrid (UPM), has developed a biometric verification system of people through their smartphones. For verification, people have to make a gesture in the air while holding mobile phone in hand. This gesture identification can be invented by people, who can also select their handwritten signature made in three dimensions. The results obtained by this method achieved accuracy rates close to 98% against forgery in several experiments in which was recorded and analyzed a person performing his signature in the air. This result greatly improves current verification systems for mobile phones, where, if it were to record a person writing his PIN, the verification system would break.

Technology solution supported by the Technical University of Madrid

Technology solution

This technology provides a software solution for the verification of people using a Smartphone. The only requirement is a mobile phone with an accelerometer, through which capture the movements of the repetition of signatures in the air. **In-Air Signature achieve.** Having a low computational cost and an architecture where all processing is done on the mobile device, resulting in real-time verification.

On the other hand, this technology with reduced deployment cost has a wide range of application to different sectors and combination with other technologies.

Areas of application

- Security
- ICT applied to network services and infrastructure.
- ICT applied to digital content.

"The proposed technological solution is a big improvement in security verification systems on mobile phones"



Market demands

- **Security**
 - Current Capture and biometric verification systems are high-cost and mainly applied to security on military and government sectors.
 - It has been widely demonstrated the vulnerability of current solutions based on two-factor authentication (typically the mobile phone, “what you have”, along with the PIN number).
- **ICT applied to network services and infrastructure**
 - The development of protocols for mobile payment, such as NFC, and the strong involvement of multinationals suggests that mobile payment is near a reality.
 - The market for mobile payments, with a wide variety of companies, partnerships and initiatives, is extremely fragmented and competition is intense. In this market biometric security is presented as a plus applicable to them all and an added value to their products.
- **ICT applied to digital content**
 - High penetration of smartphones, chosen by many users as their personal electronic device.
 - The technology for the protection of smartphones is not very advanced, as well as user authentication and identification for the use of applications and network services.

“The mobile payment, as well as, applications and adoption of smartphones are a high growth market in which this solution presents low cost, easy integration with other applications and high security”

Market potential

- **Security**
 - Biometric security on mobile device market revenues will increase from \$ 30 M in 2011 to \$ 161 M in 2015.
 - The number of users will experience an increase of 4 million in 2011 to 39 million in 2015.
- **ICT applied to network services and infrastructure**
 - Payments by Mobile ranks first in the ranking of the budget for technology leading financial institutions
 - The annual growth rate for mobile payments is estimated at 54%, from 49,000 million to 426,000 millions in 2015.
- **ICT applied to digital content**
 - The number of smartphones will grow from 1,500 million in 2011 to 2,000 million in 2015.

Competitive advantages

- The realization of the signature is unique to each individual. The imitation of the firms with recorded material is very difficult (about 2% accuracy), similar to handwritten signatures. Falsification has a 100% success after having seen a PIN code, and also it can say, guess, copy, etc.
- No additional hardware required except an accelerometer, which usually comes included in today’s mobile phones.
- Lower cost to the existing market solution with a similar level of biometric security. Ease of integration with the systems of the organization. High interaction with mobile applications and wide versatility of application to different needs (mobile games, mobile payments, etc.).
- Expandable to other devices with accelerometers (TV remotes, pointers, etc.)
- Users accustomed to a written signature, so it is not required to invent a new pattern. Minimally invasive technique.

References

- Extensive research career and business collaboration. Commercial interest in this technological solution have been shown at national and international level.
- Second prize of the ninth edition of the awards actúaUPM (Business Creation Competition of the UPM) for the best business idea.

IPR

- Software registration M-005532/2013

Development stage

- Concept
- R & D
- Lab Prototype
- Industrial Prototype
- Production

In-air signature contact

Javier Guerra Casanova.
Cármén Sánchez Ávila.
e: {jguerra,csa}@cedint.upm.es
w: <http://www.gb2s.es>

UPM contact

Innovation, Commercialization and
Entrepreneurship Area
Centre of Support for Technological Innovation –
UPM
e: innovacion.tecnologica@upm.es

ESCAM. An alternative to mechanical scanning.

A low-cost reflectarray antenna based on liquid-crystal cells that provides beam scanning at millimeter-waves with improved reliability

ESCAM (Electronic Scanning Antenna for Millimeter-wave applications) is a low-cost solution for electronic beam scanning at frequencies above 100 GHz is desirable, as an alternative to mechanical scanning, for certain applications in communications, radar, image reconstruction for security and scientific missions in space.

This invention provides a technological solution for low-cost and reliable antennas based on liquid crystals to provide electronic beam scanning in mm-wave and Terahertz ranges. The invention improves the antenna performance by using multi-resonant cells in one or two layers of liquid crystal. At present, there is not any available technology that provides electronic beam scanning at frequencies around 100 GHz and above. The main advantages of the new technology with respect to mechanical scanning using motors are: low-cost, higher reliability and low power consumption.

Technology solution supported by the Technical University of Madrid

Technology solution

Electronic beam scanning would be desirable at frequencies above 100 GHz for certain applications. Prior demonstrators of beam scanning antennas based on liquid crystals used a single resonant patch above a layer of liquid crystal (LC) as phasing cells. This configuration showed significant limitations in bandwidth, range of phase and losses, which made them unsuitable for practical applications.

ESCAM solves the problems mentioned above, by using multi-resonant cells, which provide an improvement in range of phase, bandwidth and losses. The multiple resonances can be implemented in each phasing cell by using 3 parallel dipoles, where the dipole lengths are optimized to improve the bandwidth and phase range. Another alternative is to use two layers of LC for a further improvement of the scanning performance.

“Development of low-cost antennas based on liquid crystals to provide electronic beam scanning in mm-wave and Terahertz ranges”

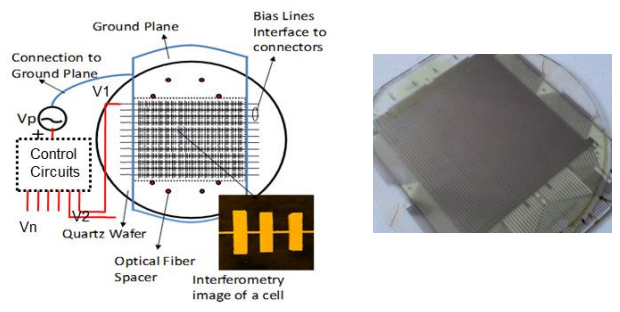

Areas of application

- **Security:** Application to image reconstruction equipment for weapon and explosive detection.
- **Space:** Instruments for Earth & Atmosphere observation
- **Nanotechnology, materials:** Development of new LC-materials and technologies for beam scanning in THz.

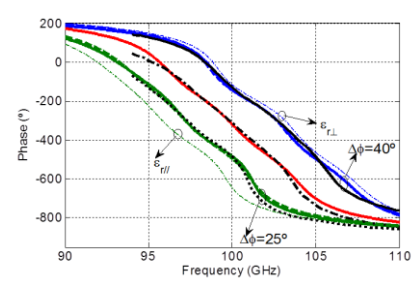

Market demands

▪ Space

- Reliable beam scanning at mm-wave and Terahertz for instruments to study the atmosphere, as an alternative to mechanical systems using motors, which require a special lubrication and should be on operation during several years.
- Space industry needs technologies that allows research in different parameters and range of frequencies.
- Due to high cost to orbital a satellite, low weight technologies are crucial.

▪ Security:

- After 11-S, the security agencies and market are looking for new technologies that improve weapon and explosive detection.
- In recent years, a wide range of privacy laws have emerge in development countries. Technologies such as radars in the range of sub-millimeter frequency bands, that allows security screening without personal intrusion, are an important step to obey this new legal imperative.

▪ ICT, embedded systems for communications:

- Ultra wide-band communications is an incipient market that allow high-data-rate and well-suited for radio-frequency-sensitive environments, indoor and out-door.

The Global Satellite Industry Revenues has increase 7 % in 2012, with 189,5 billion dollars, outpacing both worldwide economic growth rate (2,3%) and U.S. growth (2,2%)

Market potential

▪ Space

- Over 115 satellites will be launched each year worldwide the next 10 years [Euroconsult-ec]
- The Global Satellite Industry Revenues has increase 7 % in 2012, with 189,5 billion dolars, outpacing both worldwide economic growth rate (2,3%) and U.S. growth (2,2%) [Euroconsult-ec].

▪ Security

- After 11-s, EEUU have spend more tan 400.000 million dollars improving security systems and technology both companies and government [Expansion.com].
- U.S. Explosives Screening Systems, Service, Upgrade & Installation Market is expected to rise from 1.5 billion in 2009 to 3,3 billion in 2014 [Homeland Security Market Research].

▪ ICT, embedded systems for communications:

- In 2013, over 2,7 billion people are using the internet, with corresponds to 39% of the world's population [International Telecommunication Union, ITU].

Competitive advantages

- The proposed technology provides a low-cost and reliable solution for electronic beam scanning at frequencies in the range of mm-waves and Terahertz, as an alternative to mechanical scanning using motors.
- The cost of ESCAM is much lower (at least one fourth) of the cost of complex mechanical scanning systems.
- At present, there is not any available technology that provides electronic beam scanning at frequencies around 100 GHz and above.
- The power consumption is very low for the proposed electronic beam scanning, at least one tenth of the consumption in mechanical systems using motors.
- Low-cost imaging in real time for weapon and explosive detection.

References

- This invention is being developed with financial support from the Spanish Government (CICYT and Consolider) and from ESA. A reference from ESA is: "this approach can be used to create a new class of fully integrated electronically controlled antenna systems, 'smart sensors', and tunable FSS for space science instruments at mm, sub - mm and THz wavelengths".

IPR

- Patent granted in Spain ES2388213

Development stage

- Concept
- R & D
- Lab Prototype
- Industrial Prototype
- Production

ESCAM contact

J.A. Encinar, G. Pérez-Palomino, M. Barba, X. Quintana, M. Andreas, J.M. Oton, A. Broquetas, J. Abril, E. Novae {jose.encinar@upm.es, xabi@tfo.upm.es, broquetas@tsc.upc.edu}

UPM contact

Innovation, Commercialization and Entrepreneurship Area
Centre of Support for Technological Innovation – UPM
e: innovacion.tecnologica@upm.es

BETsMA. Mitigating space debris with just one click

A friendly software aimed at the design of space debris mitigation missions using bare electrodynamic tethers

BETsMA, a software developed under the FP7/Space project BETs funded by the European Commission, aim at preliminary mission analysis using bare electrodynamic tethers. It brings together in a friendly tool more than 20 years of research on bare tethers and the latest developments by the BETs Consortium. Using BETsMA, both experts and beginners on tethers will find the optimum tether system for a given space debris deorbiting mission, i.e. initial orbit altitude and inclination and mass of the host satellite. The software provides the main figures of merits, including deorbit time, mass of the subsystems, satellite trajectory and tether survival probability among others. Its friendly user interface and optimized algorithms validated against previous works on tethers are specially designed for quick parametric studies in a broad range of orbital and tether conditions..

Technology solution supported by the Technical University of Madrid

Technology solution

BETsMA is a software dedicated to the preliminary mission analysis of deorbit missions with bare electrodynamic tethers, i.e. to bring back to the Earth the satellite at the end of its live. Its friendly-user interface makes BETsMA an ideal tool for non-expert engineers on tethers, who need a fast but accurate estimation of the parameters of the mission. It includes a tool to makes optimal tether design and a detailed flight simulator. Its intuitive interface, fast algorithms and thorough set of outputs, including evolution of the orbital parameters, deorbit time, tether electrical values along the deorbiting, and survival probability among others, make BETsMA a unique tool. The interface and the visualization tool is designed to carry out parametric studies in a broad range of conditions.

Areas of application

- **Space:** preliminary design of deorbit missions with electrodynamic tethers.
- **Security:** parametric studies of space debris remediation scenarios in a broad range of conditions.

"The user-friendly interface of BETsMA gives a fast an accurate response to the main issues related to deorbit satellite missions with bare electrodynamic tethers"

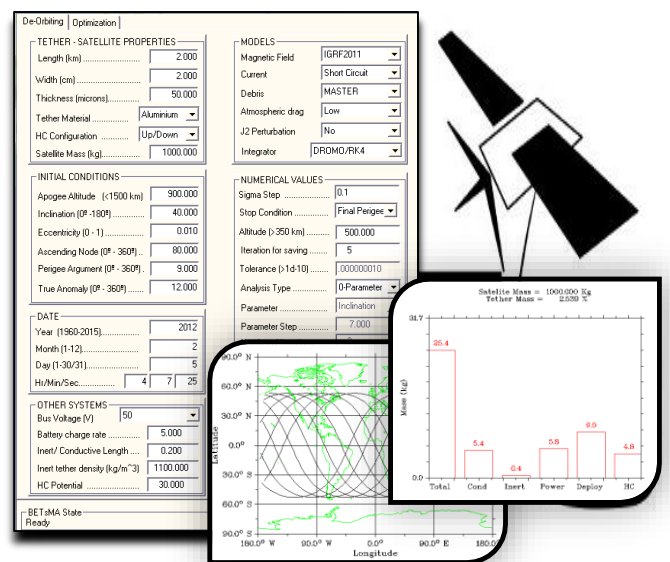

The screenshot displays the BETsMA software interface with several panels:

- TETHER - SATELLITE PROPERTIES:** Length (km) 2,000; Width (cm) 2,000; Thickness (microns) 50,000; Tether Material Aluminum; HC Configuration Up/Down; Satellite Mass (kg) 1000,000.
- MODELS:** Magnetic Field IGRF2011; Current Short Circuit; Debris MASTER; Atmospheric drag Low; J2 Perturbation No; Integrator DROM/RK4.
- INITIAL CONDITIONS:** Apogee Altitude (km) 900,000; Inclination (°) 40,000; Eccentricity (0 - 1) 0,010; Ascending Node (°) 80,000; Perigee Argument (°) 9,000; True Anomaly (°) 12,000.
- NUMERICAL VALUES:** Sigma Step 0,1; Stop Condition Final Perigee; Altitude (km) 500,000; Iteration for saving 5; Tolerance (1-10) 0,00000010; Analysis Type O-Parameter; Parameter Inclination; Parameter Step 7,000.
- DATE:** Year 2012; Month 2; Day 5; Hi/Mm/Sec 4/7/25.
- OTHER SYSTEMS:** Bus Voltage (V) 50; Battery charge rate 5,000; Inert/Conductive Length 0,200; Inert tether density (kg/m³) 1100,000; HC Potential 30,000.
- Bar Chart:** Shows Mass (kg) for different components: Total (38.7), Cond (5.4), Inert (0.4), Power (2.8), Deploy (9.0), HC (4.6).
- Map:** A globe showing the satellite trajectory in green.

PASSIVE ELECTRIC PROPULSION

Market demands

- Space industry is threaten by 6000 tons of space debris, which now causes, in average, one collision each decade.
- Due to next launches, the Low-Earth-Orbit (LEO) satellite population will increase, thus making worse the space debris problem.
- ESA and NASA analyses suggest that, even without new launches, the number of objects will grow due to collisions.
- Recommendations and responsibilities has been approved to remediate the space debris problem. New ones will be soon implemented by governments and space agencies.
- A long term solution is to deorbit next launched satellites and final rocket stages. It requires a deorbit technology, which should be light, reliable and efficient at LEO.
- Space agencies look for disruptive technologies like tethers, which not only satisfy the above conditions but also are passive and do not need propellant neither batteries.
- Non-specialized engineers on tethers technology require a user-friendly software to carry out parametric analyses of deorbiting missions with tethers. These quantitative values can be used to make comparisons with other technologies and take decisions.

“Space agencies, companies and research groups need a tool to design tether missions and calculate their costs”

Market potential

- More than one thousand satellites will be launched the next decade with a cost of manufacturing and launching about 150 billion €.
- A satellite failure due to a collision with space debris produces both operational and economical losses, which can reach values about hundreds of million €.
- Decreasing the mass of the deorbit technology is crucial due to the high costs (1kg of launched mass is about 10000 €).
- Currently, there are 6000 tons of space debris. BETs Consortium estimate that the deorbit cost using a tether could be about 50% smaller than a chemical rocket.
- Space agencies, companies and research groups are potential clients of BETsMA, because they all need fast but accurate estimation of the tether system performances.

Competitive advantages

- BETsMA is the first simulator to be used by both expert and non-specialised engineers on tethers.
- Its optimization tool, aimed at finding the tether geometry, makes BETsMA an unique tool.
- Comprehensive software with a complete catalogue of outputs, including the evolution of the orbital elements, the tether electrical variables, mass of all the subsystems, and survival probability among others.
- User-friendly and intuitive interface and a visualization tool also integrated in the program. They are design to carry out parametric analysis of tether missions.
- It includes the latest developments on tether flight simulators like a detailed model for the current collection and an efficient orbit propagator.
- BETsMA manual gives a description of the implemented physical models and some mission examples to start with.

References

BETsMA has been developed under the FP7/Space project “BETs” (No 262972) in the Departamento de Física Aplicada de la ETSI Aeronáuticos. The coordinator of the project, Prof. J. R. Sanmartín, introduced the bare tether concept in 1993 and the optimization scheme used by BETsMA.

IPR

- Software registration M-5377/2014

Development stage

- Concept
- R & D
- Lab Prototype
- Industrial Prototype
- Production

BETsMA contact

Gonzalo Sánchez Arriaga
e: gonzalo.sanchez@upm.es
w: <http://www.thebetsproject.com>

UPM contact

Innovation, Commercialization and
Entrepreneurship Area
Centre of Support for Technological Innovation -
UPM
e: innovacion.tecnologica@upm.es

Structural Fiber Sensing. Efficient maintenance of smart structures

System for detection the structural damage appearance by the elastic wave propagation monitoring in solid using a fiber optical sensor network embedded in the structure

Currently the structural maintenance strategies are based on periodic time schedule inspections that are expensive and inefficiency, as it is no distinction between damage and undamaged structures procedures. It is proposed a system to interrogate an embedded fiber optic sensor network (low weigh and low intrusive) and monitor the elastic wave propagation through the structure. During any kind of damage appearance and growth, slight amplitude and high frequency elastic waves are generated and propagated everywhere in the structure. From the data of this measuring signal is possible to determine damage position and damage severity. Real time measurements allow knowing the state of the structure in every moment, making possible to implement a condition-based maintenance. This technique can improve the efficiency and the time of operation, reducing financial and maintenance cost of all kind of structures.

Technology solution supported by the Technical University of Madrid

Technology solution

This technological solution proposes a measuring system based on Fiber Bragg Grating sensors (FBGs). FBG sensors can be easily multiplexed in a single optical fiber of only 0.2 mm diameter, which can be easily embedded or mounted in a structure.

Damage appearance generates an elastic wave of low amplitude (less than 0.01 microstrain) and very high frequency (between 50kHz and 1MHz).

The ability of perform this measurements and process these wave signals will allow to determine damage location and damage assessment which improves safety and maintenance costs.

Areas of application

- **Aerospace:** commercial aircraft, military aircrafts and helicopters maintenance.
- **Energy:** wind turbine blade maintenance.
- **Materials:** complex civil structures (bridges, pipeoil, etc.)

"Structural damage detection by an integrated fiber optic sensor network embedded or fixed in the structure, will increase the safety, reduce the maintenance costs and increase the operation time".



Market demands

- High cost of complex engineering structures require long operation time. Shorter maintenance time will reduce the cost and increase the use of the structure.
- Non destructive techniques currently employed are high dependent of operator. Integrated and atomized systems will simplify the decision making phase and the repair design.
- A integrated sensor network will increase the safety, as real time monitoring allows to detect damage in the early stage.
- The size will limit the selection of NDI procedure and the exact determination of the damage area.
- Traditional sensors require a high dense sensor network, but the implementation is extremely limited due to weigh and geometry perturbances.

“Maintenance based on the real condition of the structure require an integrated sensor network that can provide the real condition of the structure in real time. This is mandatory to reduce operational cost”.

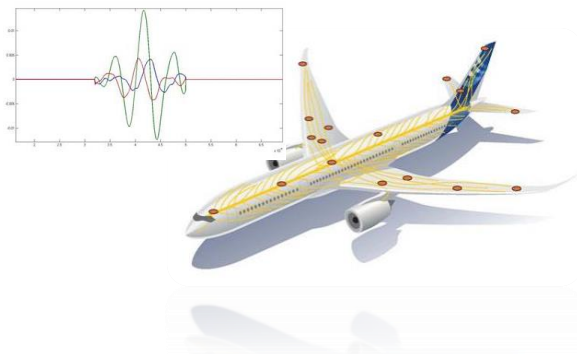

Market potential

Aerospace

- It is expected an increment of air traffic of 6% every year until 2035.
- Currently, aircraft maintenance moves 75 billion dollars per year. 9% of this amount is devoted to structural maintenance.

Energy

- Maintenance cost are the 3% of the total cost of a wind turbine blade.
- Off-shore wind turbine blade require a reduction of 40% to became cost competitive.

Materials

- Current bridge structures maintenance cost is 5 billion euros only in Europe.
- Maintenance cost can risk the 8% of the total cost in the most complex civil structures.

Competitive advantages

- Despite that piezoelectric sensors are already used to detect elastic waves, and even it is possible to find some commercial equipments in the market, cabling weigh and external perturbances have limited its application field. The use of fiber optic sensors allows to implement this technology in all kind of structures, such as aircrafts or wind turbine blades.
- Fiber optic geometry (0.2mm diameter) and the possibility of introducing more than one sensor in the same fiber, allows to perform a high density sensor network with low perturbation and without weigh penalty.
- Fiber optic sensors are also immune to electromagnetic interference, a compulsory requirement in the aerospace and energy fields.
- Traditional sensors are limited by size and directionality; fiber optic sensors use this characteristics to improve damage detection.

References

- The research group has been involved in several European and national R&D projects since 1996.
- Currently the group is working with private companies to develop solution for damage detections based on fiber optic sensors.

Development stage

- Concept
- R & D
- Lab Prototype
- Industrial Prototype
- Production

Structural Fiber Sensing contact

Antonio Fernández-López
ETSI Aeronáuticos - UPM
e: antonio.fernandez.lopez@upm.es

UPM contact

Innovation, Commercialization and
Entrepreneurship Area
Centre of Support for Technological Innovation –
UPM
e: innovacion.tecnologica@upm.es

SILFRARED PHOTODETECTORS. The dark side of light

Inexpensive silicon based photodetectors for night/thermal vision

Silfrared technology is a monocrystalline silicon based new concept that enhances silicon detectivity in the near and mid infrared range. Silfrared devices are uncooled and fabricated with non-contaminant and abundant elements, being the fabrication procedures easily integrated with CMOS technology. This properties can provide devices over a 20% cheaper than existing technologies. Silfrared will cover market's demand for inexpensive devices sensible to the near IR and extended to the visible range that have been pursued since the early 90's.

Technology solution supported by the Technical University of Madrid

Technology solution

Silfrared devices are based on the illumination-coupled infrared new concept for silicon photodetectors technology that can provide high response in the near- and mid-IR range (added to visible range) with a monocrystalline silicon based uncooled device. In contrast to other mid-IR commercial photodetectors (made of materials different from Si) these devices can take advantage of the low price of Si raw material and processing techniques, and of its non-contaminant character. This technology is also fully compatible with traditional Si CMOS technology.

Areas of application

- **Security:** night vision cameras, military applications,...
- **TIC:** optical communications, inspection and sensing for industrial applications, next generation of computing and gaming systems,...
- **Others:** medical imaging, automotive safety, astrophysics,...

"Silfrared concept enhances Si detectivity in the mid-IR range at room temprature, fully compatible with CMOS technology, saving more than 20% of the cost"



Market demands

▪ Security/military

- Most infrared detectors need to be cooled, what prevents a reduction of the device size, specially interesting for security, firefighting and military applications. Uncooled devices are therefore very interesting.
- Silicon based devices are also very demanded, not only for the reduced cost of silicon raw material, but also because it is not affected by political issues, since it can be obtained everywhere.

▪ **Automotive:** a new generation of infrared sensors are required for night vision, pedestrian security and collision prevention.

▪ **ICT:** communication in the infrared band is widely used in our daily lives (remote controls, computing, vehicles, medical diagnostic,...). An important cost reduction is highly desirable to many industries.

“There is a huge underpenetrated market for an uncooled IR photodetector technology based on silicon. Inexpensive devices for the near IR detection extended to the visible range have been pursued since the early 90’s”

Market potential

- The mid IR sensor market at 789 M\$ in 2012 are anticipated to reach 7 B\$ in 2019.
- North American IR detector and module market, estimated at 1 B\$ in 2008, the largest in the world.
- Sofradir, the number one developer and manufacturer of a key class of infrared (IR) detectors for military, space and industrial applications, had annual sales in 2011 of 150 M€ (two thirds in exportations. Sofradir is holding a 25% market share.
- Sofradir shipped 40.000 IR detectors, worldwide. Customers include the US Army, Thales, Sagem, Selex, Thales Alenia Space, ESA (European Space Agency) and FLIR Systems.
- ULIS, Sofradir subsidiary, had 50 M€ benefits in 2012.
- FLIR, world leader in the design, manufacture and marketing of thermal imaging infrared cameras, had 1.4 B\$ revenues in 2012 (628 M\$ in thermal vision and measurement division, 486 M\$ in surveillance division and 158 M\$ in raymarine division). 619 M\$ came from government systems. 700 M\$ came from United States and 350 M\$ from Europe.
- FLIR invested 10% revenue in R&D.
- There are underpenetrated existing markets: security cameras (7.7 B\$), military infrared (7 B\$) or automotive (6 B\$).

Sources: [\[WinterGreenResearch\]](#), [\[ReliablePlant\]](#), [\[optics.org\]](#), [\[flir.com\]](#).

Competitive advantages

- Direct application for a 20 B\$ underpenetrated market. Silfrared is the only known technology based on silicon, uncooled, that works for the visible up to mid-infrared.
- Saving more than 20% of the device cost: there is no need for cooling, while other silicon based devices must work at cryogenic temperatures (liquid nitrogen temperature: -196 °C) to reach the mid-infrared range.
- Devices based on abundant, cheap and non-toxic elements such as silicon (28% of the earth crust) and titanium (0.5%). Actual devices are based on elements like lead (0.0014%) or cadmium (0.000015%).
- Fast response devices. Sustitutive products such as microbolometers are comparatively slow.
- Fabrication processes compatible with CMOS technology (90% of the actual technology), reducing costs.

References

- Research group with an experience of more than 35 years in the microelectronics field.
- Technology developed in coloboration with the Solar Energy Institute of Madrid (Spain).

Development stage

- Concept
- R & D
- Lab Prototype
- Industrial Prototype
- Production

Silfrared contact

Dr. Javier Olea Ariza
e: j.olea@upm.es

UPM contact

Innovation, Commercialization and
Entrepreneurship Area
Centre of Support for Technological Innovation
– UPM
e: innovacion.tecnologica@upm.es

VecMan – Vectorial Magnetic Nozzle

Simple solution to control the direction of the thrust vector in space plasma thrusters, with no moving mechanical parts, and without affecting the internal operation and efficiency of the thruster or the satellite operation.

Researchers from the Technical University of Madrid propose a new solution to guide a plasma jet using a steerable magnetic nozzle. Its application allows deflecting the thrust vector 10 to 15 degrees in any direction from the thruster axis. It provides greater flexibility for the space mission, allowing the compensation of thrust misalignments **without requiring any gimbaled platform**. The system is applicable to any plasma thruster compatible with a quasi-axial magnetic field, which covers many of the existing and future plasma thrusters.

Technological solution supported by the Technical University of Madrid

Technological solution

The proposed solution consists of a magnetic field generator that allows the controlled deflection of a plasma jet without any moving parts.

This constitutes a clean alternative to current solutions characterized by the presence of moving parts or naked electrodes, which unavoidably increase the weight and complexity of the system, and can deteriorate the efficiency of the thruster.

Areas of application

- **Space:** application in space missions including large institutional agencies and large contractors of space technology.

"VecMan can control the thrust vector direction from a space plasma thruster in 10-15 degrees"

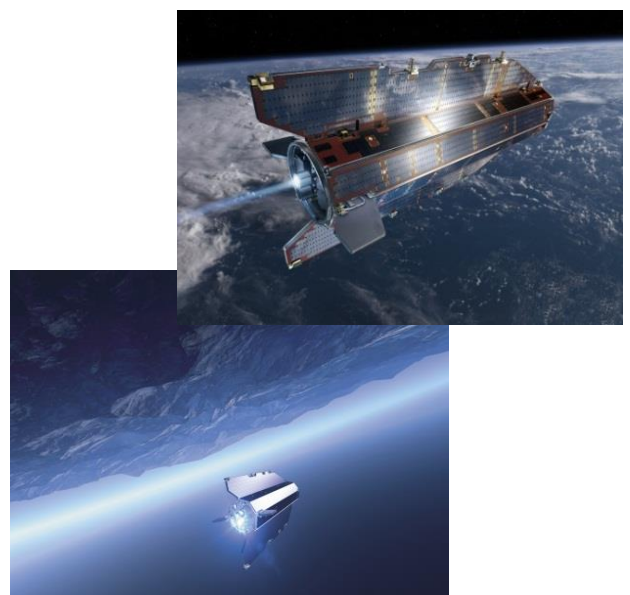

Source: European Space Agency

Market demands

▪ Space & Communications

- Manufacturers and integrators of satellites and spacecraft often point the need to re-orient the thrust vector in 5 to 10 degrees during the mission. These small deflections would suffice to compensate the drifts in center of mass position that occur through the life of the satellite, as well as any manufacturing misalignments.
- Enabling thrust vector control provides greater freedom in the propulsive tasks of a mission, like the ability to use the main thruster to change the attitude, or to de-saturate the reaction wheels while thrusting. This is specially interesting for both long duration, low thrust transfer manoeuvres and orbital station keeping.
- Current solutions rely on mounting the thrusters on gimballed platforms, with high weight costs and associated complexity.

“Vectorial Magnetic thrust with no moving mechanical parts and without affecting the operation of the satellite, greatly increasing the operational capacity of the propulsive system”

Market potential

▪ Space

- In the period 2013 - 2022 operators and governments will launch an average of 115 new satellites per year to meet the demand for voice, data and broadcast [Euroconsult].
- The revenue from the manufacture and launch of these 1,150 satellites is estimated at \$236,000 million [Euroconsult].
- There are currently more than 240 active satellites based in electric propulsion [Aerojet data].
- The satellite industry volume will triple between 2001 and 2012 [SIA].
- 3,164 space payloads proposed to be constructed between 2013 and 2032, with a business value of \$235 billion [Satellite Markets & Research].

▪ ICT, embedded systems for communications

- In 2013, over 2.7 billion people are using internet, which corresponds to 39% of the world's population [International Telecommunication Union, ITU].

Competitive advantages

- No mechanical parts (e.g. gimbals), nor electrodes exposed to plasma.
- The concept requires only a slight modification in the magnetic field generator of those thrusters that have one (or its addition to thrusters without one)
- There is a considerable gain in simplicity, reliability, weight, and operational capacity by allowing 10-15 degrees deflection.
- Many of the space plasma thrusters existing or under development are covered, including gridded ion engines, helicon plasma thrusters, applied field magneto-plasma-dynamic thrusters (AF-MPDT), the VASMIR engine, Cylindrical Hall effect thrusters, HEMP thrusters and Hall effect thrusters with magnetic cusps.

References

- Research group with extensive experience in the field of space plasma propulsion and plasma physics, and a continued collaboration with leading companies and industry organizations worldwide.
- Active participation in multiple R & D projects related to magnetic nozzles [United States Air Force (FA8655-10-1-3085 and FA8655-12-1-2043), EU-7th (218862) and ESA (4000107292/12/NL / CO)]

IPR

- Patent applied in Spain P201331790

Development stage

- Concept
- R & D
- Lab Prototype
- Industrial Prototype
- Production

VecMan solution

Mario Merino Martínez; mario.merino@upm.es
Eduardo Ahedo Galilea; eduardo.ahedo@upm.es

UPM contact

Innovation, Commercialization and
Entrepreneurship Area
Centre of Support for Technological Innovation –
UPM
e: innovacion.tecnologica@upm.es

AFeNSat. Revolutionary technology for the next generation of satellite communications.

New configuration of dual-frequency band antenna feed for single circular polarizations, with significant benefits to existing solutions in the market.

The current onboard multi-spot satellite antennas and their corresponding ground feeds require dual-frequency band and circular polarization. There are currently two technological solutions that have several power restrictions and/or a very high cost due to their mechanical complexity. The new feed architecture of the invention is based on a Diplexer + Biphas-Polarizer. It provides excellent electrical specifications (Isolation and Axial Ratio) with a very simple low-cost mechanical structure .

Technological solution supported by the Technical University of Madrid

Technological Solution

AFeNSat (Antenna Feeding Network for New Generation Satellite Communications) is based on the combination of a Diplexer and a new Biphas-Polarizer. This new configuration provides enhanced electrical characteristics: bandwidth, matching, Axial Ratio (AR) and isolation that solve the restrictions of the actual feeds based on the combination of OrthoMode Transducer (OMT) and corrugated Monophase Polarizer. Also, this solution simplifies the mechanical fabrication with the subsequent cost saving compared with the six-port junction-based alternative.

The new feed, unlike current, no need of alignment of its components, thereby providing great versatility to the antenna structure, which can be used to reduce their size and complexity.

Areas of application

- **Space.** Application in multi-spot antennas onboard satellites.
- **ICT applied to embedded systems and components.** Application in ground station antennas. (SATCOM)

“AFeNSat solves the alignment issues of its constitutive components and has significant advantages in terms of electrical performance, as well as low-cost and simple mechanical assembly”

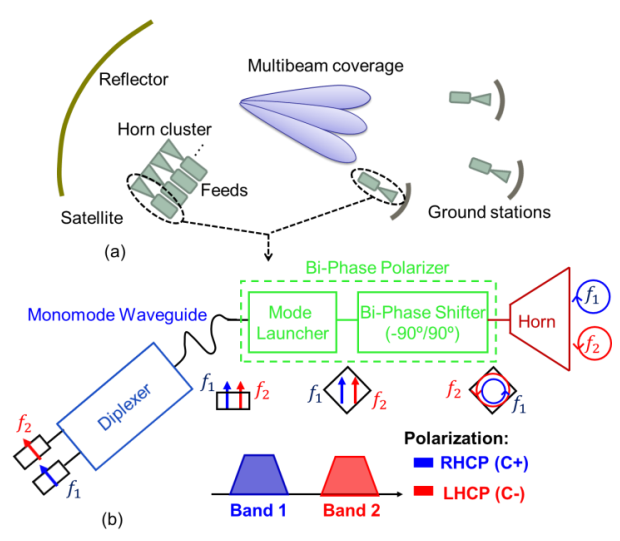

Market needs

Space

- The multi-spot satellite antennas need of a large number of feeds, designated as USER-FEED, usually working in the Ku/Ka-band (20-30 GHz) with circular polarization.
- At present, the driving solutions are: 1) Dual-Band Corrugated Polarizer + OMT and 2) six-port junctions combined with single band polarizers. The first alternative presents important electrical constraints and the second one is rather complicated and expensive due to its cumbersome mechanical structure.
- The new proposed feed achieves the required stringent electrical specifications with a simple low-cost light structure and easily integrable in a multi-spot antenna.

Ground stations (VSAT)

- For ground stations (SATCOMs) operating in circular polarization, the isolation between bands is a critical parameter. The new feed easily achieves isolation levels above 100 dB, without deteriorate the return loss or the AR.
- In these applications, compact feeds add a significant advantage to the antenna.

Competitive advantages of the solution

- The proposed new feed provides an excellent solution for new multi-spot Ku/Ka antennas onboard satellites and at ground stations (SATCOMs).
- It provides excellent electrical specifications: return loss better than 27 dB and AR better than 0.25 dB with a simple and compact structure. This allows a great reduction in mass and volume, which is critical for onboard antennas.
- The advantages over current solutions are the electrical performance, the mechanical simplicity and the versatility for interconnection.
- It significantly reduces the cost of the current solutions.

References

This invention is the result of a long research and development activities carried out in recent years. Funding has come from the Spanish Government (CICYT). It is also noteworthy the collaboration with companies in the sector (EADS, RYMSA, THALES), that have let us know the technological requirements of the aerospace market.

Industrial protection

- Patent granted in Spain ES2441471
- International patent applied via PCT PCT/ES2014/070462

Grado de desarrollo

- Concept
- Research
- Prototype-Lab
- Industrial prototype
- Production

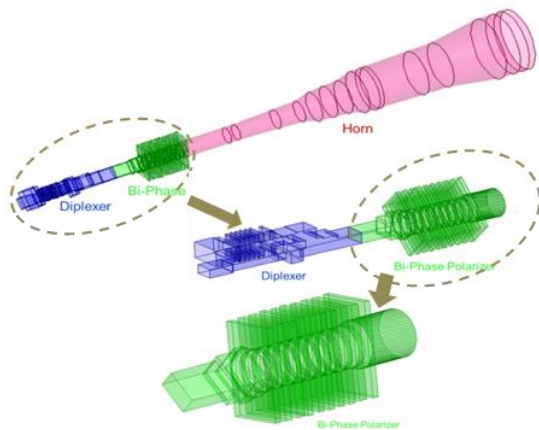

Market Potential

Space

- During the next 10 years about 115 satellites will be launched by year. [Euroconsult-ec]
- The satellite industry has increased its growth by a factor of 3 between 2001 and 2012. [SIA]
- We have identified 3,164 space payloads proposed to be constructed between 2013 and 2032, with a value of \$ 235 billion business. [Satellite Markets & Research].

ICT applied to embedded systems and components

- In 2013, more than 2.7 billion people use the internet, which corresponds to 39% of the world population [International Telecommunication Union, ITU]
- In 2015 is expected to have 202 million Internet-connected devices in U.S. homes [Satellite Markets & Research].

AFeNSat contact

C: A. Leal-Sevillano, J. M. Rebollar, J.R. Montejo-Garai, J.A. Ruiz-Cruz
e: caleal@etc.upm.es ; jmmr@etc.upm.es ; jr@etc.upm.es ; jorge.ruizcruz@uam.es

UPM contact

Innovation, Commercialization and Entrepreneurship Area
Centre of Support for Technological Innovation – UPM
e: innovacion.tecnologica@upm.es

AUTOSTEERING. Equipment for automatically controlling the steering of a vehicle

Device for the automatic steering control of any road vehicle without driver intervention and minimal modifications in the internal mechanical of the vehicle.

The present invention is an equipment that allows controlling the steering of a vehicle from a controller by automating the steering wheel and without driver intervention. This solution overcomes the problems found in the state of the art. Thus, it is independent of the type of vehicle and type of steering assistance (electric or hydraulic), including the presence or absence of such assistance. This invention does not enter permanent changes on the vehicle or interfere with the driving task. In addition, the coupling or decoupling of single mode is controlled automatically and no manual and other developments, being able to carry out moving and instantaneously, from the same processor that controls the direction, and the driver does not lose complete control the direction of the vehicle. The device has been mounted on a vehicle and used for the realization of an automatic collision avoidance system.

Technology solution supported by the Technical University of Madrid

Technology solution

The solution refers to an equipment that allows controlling the steering of a road vehicle from a controller without driver intervention by automating the wheel.

Consequently, it is a device incorporated in a motor vehicle which includes an assembly comprising an electric motor which drives a toothed wheel which engages on a chain secured to the drag another steering column device gear.

To link or unlink as desired at any time the rotation of the electric motor and the steering column, changing from manual to automatic or vice versa, a clutch consists of an electromagnet is introduced.

"Universal device for any vehicle type to control the steering of a road vehicle without driver intervention"

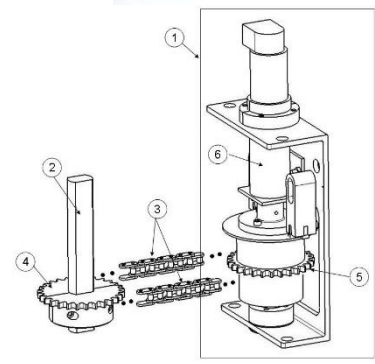
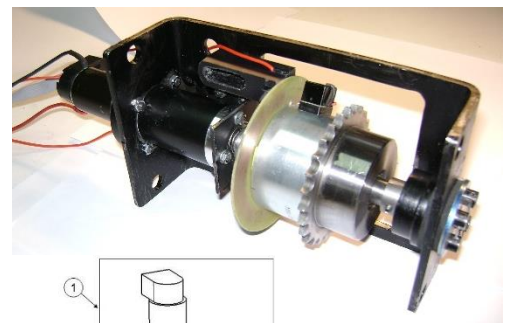

Areas of application

- ICT applied to mobility, intelligent transport systems
- Transport

Market demands

- **ICT applied to mobility, intelligent transport systems**
 - The autonomous vehicles have been identified as a trend for 2014 by different media.
 - Autonomous driving systems: Under certain conditions, the autonomous driving is safer and more efficient alternative, finding studies that claim that autonomous driving dramatically reduce accidents and road deaths.
 - Among the objectives of European Horizon 2020, ICTs applied to transport plays an important role, one of the specific topics using automation.
 - It is expected that autonomous vehicles not only reduce accidents (some estimates talk of rate close to zero accidents), but also emissions and pollution due to drive in a more efficient way vehicles.
- **Transport application**
 - Numerous research about transportation need to automate vehicles to test their developments, for example, collision avoidance systems for autonomous driving or even as support for inductive load dynamic systems.
 - After successful testing by Google, most vehicle manufacturers have been introduced in the autonomous vehicle race.

“By 2050 most vehicles will be autonomous vehicles”

Market potential

- Annual sales of autonomous vehicles will increase from 230,000 units sold in 2025 to 11.8 million in 2035 [IHS Automotive].
- In 2035 it is expected that about 54 million vehicles will be autonomous vehicles in our roads [IHS Automotive].
- In 2040, 75% of vehicles on the road will be autonomous vehicles [IEEE].
- In 2050, most of the cars will be autonomous vehicles [IHS Automotive].
- The State of Nevada has permitted autonomous driving and California is in the legislative debate [Forbes].
- Automakers have spent over \$ 10 billion in "advanced systems for driver assistance" in 2011, and is expected to rise to 130 billion in 2016 [ABI Research].

Competitive advantages

- The solution is independent of the type of vehicle
- The mounting of the technology involves no permanent modification to the vehicle.
- The steering control is not bound to give orders through the internal bus vehicle communication.
- The engagement or disengagement of the autonomous mode is automatically controlled, and can be carried out in motion.
- The driver does not lose complete control of the direction of the vehicle.
- The interlock and support unit is removable.

References

- Automation solutions for vehicles of the research team have been applied to projects funded by companies such as Siemens, UAH Universities as well as competitive projects with public funding in Spain.
- The research group has an experience of over 10 years in this field and has published over 40 articles in journals.

IPR

- Patent granted in Spain: 201330627

Development stage

- Concept
- R & D
- Lab Prototype
- Industrial Prototype
- Production

Autosteering contact

Felipe Jiménez
e: felipe.jimenez@upm.es
José Eugenio Naranjo
e: joseeugenio.naranjo@upm.es

UPM contact

Innovation, Commercialization and
Entrepreneurship Area
Centre of Support for Technological Innovation
– UPM
e: innovacion.tecnologica@upm.es



Construction & Infrastructure

Construction & Infrastructure

UPM construction sector focuses on smart and sustainable solutions, including innovative materials, the design of energy efficient buildings and the development of construction systems.

ARIDOLAR

Improved mortars able to increase the useful area in buildings

[Link](#)

FORQUES

Joint applicable in new construction and renovation that prevents strain in interior walls

[Link](#)

F2TE3

Highest efficiency and freedom in the design of buildings

[Link](#)

IntelliGlass

The building as your energy source

[Link](#)

HexBrick PLUS

New designs of ceramic bricks with hexagonal cells

[Link](#)

SisBA

Avoiding involuntary movements of tribachs

[Link](#)

Check Construction & Infrastructure UPM technologies marketplace

[Website](#)

ARIDOLAR. Improved mortars able to increase the useful area in buildings

New process for manufacturing lighter mortars with higher sound and thermal insulation resistance

Regulatory changes proposed by the Spanish Technical Building Code (CTE) in 2007, have shown that many of the filling elements used in the construction of buildings do not meet the new thermal and acoustic requirements. As a solution, researchers from the Technical University of Madrid and the University of La Laguna propose the improvement of mortars using fine aggregates by including treated expanded polystyrene (EPSt). Thus, a lighter material with higher sound and thermal insulation properties, as well as better water vapor resistance -- compared to currently used mortars--, is obtained. In addition, it increases the useful area of the building.

Technology solution supported by the Technical University of Madrid

Technology solution

From the research conducted to improve thermal, acoustic and water vapor transmission properties of mortars using fine aggregates (volcanic ash) such as a pyroclastic, whose scientific name is "lapilli". This new mortar can obtain vibrated concrete blocks that meet the requirements of the CTE regulation.

In this new mortar part of the aggregate (lapilli) has been replaced by treated expanded polystyrene (EPSt).

The material obtained is lighter, more acoustically and thermal insulating as well as water vapor resistant, than the ones used today.

"The Aridolar mortars meet the requirements of the Spanish Technical Building Code 2007 in an economically viable way"

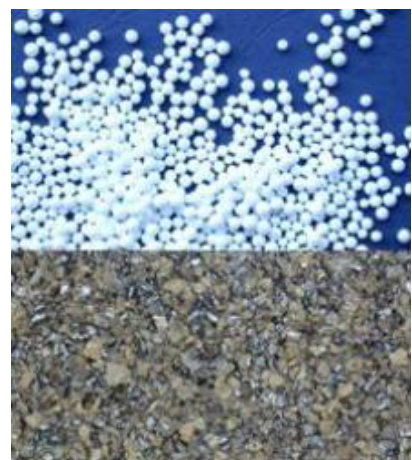

Areas of application

- **Construction:** area of precast concrete products for construction.

Market needs

Construction

The entry into force of the Basic Document "DB-HR protection against noise" and "the limitation of the energy demand" under the Spanish CTE regulation in 2007, has led to an in-depth review of the thermal-acoustic properties of the filling elements used in the construction of buildings (blocks, hollow bricks, plates, panels, etc.) confirming that many of them do not meet the requirements of the regulations.



"A 5 cm panel coated with plaster on both sides, turned out to have the same sound insulation, as a wall built with vibrated concrete blocks of 15 cm thick and coated with plaster on both sides"

Market potential

Global expectations

- The worldwide meteoric growth of construction (about 70%) is concentrated mainly in China, USA and India. [Oxford Economics y Global Construction Perspectives]
- It is expected an increase of around 33% in the USA employment for the period 2010-2020, reaching a total of 1.8 million jobs in the sector for 2020. [Statistical department, USA]

Spain

- Growth of Spanish sector around 2,5% in 2015-2020 [Oxford Economics y Global Construction Perspectives]
- In Spain, the potential housing demand will be situated above 300,000.00 homes between 2011 and 2016. [BBVA, 2011]

Competitive advantages

- Blocks, hollow bricks and panels made from this new material have remarkably improved properties including a density decrease of around 32.82%, resulting to be a lighter, and an increase of 103.64% in thermal resistance.
- Partitions and facades built with vibrated concrete blocks, would meet the CTE without having to place an interior partition (block or drywall).
- Further features: Acoustic resistance of a 15 cm wall is equal to a 5 cm panel; Flexural strength: 51.51% lower; Compressive strength: 68.85% lower; Water vapor resistance: 20.64% higher; Water vapor resistance Factor: 21.75% higher.

"The buildings built with blocks made with this new mortar will substantially increase the useful area of the building."

References

- Interuniversity Research Group with extensive research experience and collaboration with industry.

IPR

- Patent granted in Spain ES2372952

Development stage

- Concept
- Research
- Lab Prototype
- Industrial Prototype
- Production

Aridolar contact

Mercedes del Río Merino
e: mercedes.delrio@upm.es
ETS Arquitectura

UPM contact

Innovation, Commercialization and
Entrepreneurship Area
Centre of Support for Technological Innovation
– UPM
e: innovacion.tecnologica@upm.es

FORQUES. Joint applicable in new construction and renovation that prevents strain in interior walls.

New joint between slabs and walls, easy to install, which avoids stress transmission between structural elements and interior walls

Researchers from the Technical University of Madrid (UPM) have developed a board that solves the encounter between slabs and walls, designed to prevent the stress transmission between such components, essentially due to slabs' deformations. This solution, valid for walls and floors of every kind and nature, will allow to visually detect the correct positioning of the joint between the wall and the upper slab. In addition, it prevents the appearance of fissures and cracks in walls due to excessive deflection of slabs.

Technology solution supported by the Technical University of Madrid

Technology solution

The solution consists of a device designed to solve the joint that occurs in the encounter between the walls and slabs in buildings.

The system proposed does not allow transmitting the slab deformation to the interior walls. This joint is placed during the wall construction, in its encounter with the top slab.

It is a prefabricated element easy to carry and handle.

"Our solution will reduce the transmission of forces between the slabs and interior walls, both in new construction and renovation"

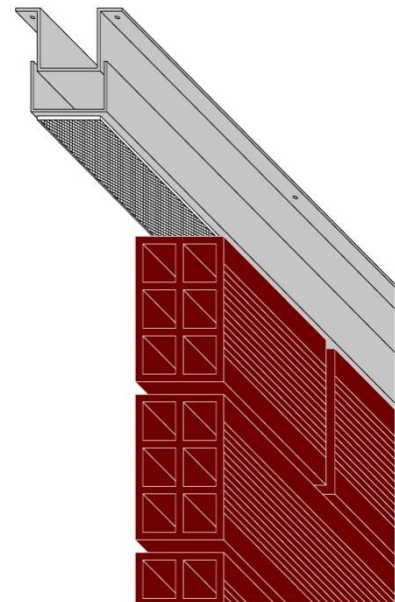

Areas of application

- **Construction:** application in both new construction and renovation.

Market needs

Construction

- Concern in the construction sector due to the deformation of increasingly flexible structural elements.
- In recent years, over 30% of building slabs have led to excessive deformation problems (Cercha nº 73/2004)
- The main claim to building insurance companies refers to interior walls damage (Cercha nº 73/2004)

“The solution developed avoids the appearance of cracks and fissures in walls due to excessive deflection of slabs”



Market potential

Global expectations

- Meteoric growth in construction sector (around 70%) concentrated mainly in China, USA and India [Oxford Economics and Global Construction Perspectives].
- An employment increase by 33% is expected in the USA during the period 2010-2020, reaching a total of 1.8 million jobs in the sector in 2020 [Department of Statistics, USA].

Spain

- Expected growth of the sector in Spain by 2.5% in 2015-2020 [Oxford Economics and Global Construction Perspectives].
- Potential housing demand will be located above 300,000 households between 2011 and 2016 [BBVA Bank, 2011].

Competitive advantages

- Valid for both new construction and renovation.
- Effective for walls and slabs of every kind and nature.
- Prefabricated element, easy to carry and handle.
- Avoids transmitting vertical loads from slabs to walls, preventing damage to the latter.
- Enables to visually check the correct construction of the wall.
- Allows to visually detect, during construction, the correct positioning of the joint between the wall and the upper slab. It decreases the risk of future problems and associated costs.
- Avoids the appearance of fissures and cracks in walls due to excessive deflection of slabs, resulting in cost savings.
- Avoids force transmission to the partition of indoor plants.
- Allows creating a joint between a deformed slab when renovating.

References

- Extensive research activities and collaboration with industry.
- Research group oriented to technological innovation and implementation of patents.

IPR

- Patent granted in Spain ES2398273

Development stage

- Concept
- R & D
- Lab Prototype
- Industrial Prototype
- Production

Forques contact

Fidel Carrasco; e: fidel.carrasco@upm.es
Tomás Gil; e: tomas.gill@upm.es
Amparo Verdú; e: amparo.verdu@upm.es

UPM contact

Innovation, Commercialization and
Entrepreneurship Area
Centre of Support for Technological Innovation –
UPM
e: innovacion.tecnologica@upm.es

F²TE³. Highest efficiency and freedom in the design of buildings

Highly transparent envelope facade system: 3,5 cm transparent facade that insulates the same as a 30 cm conventional brick wall

A multidisciplinary research team from ETS Arquitectura and Facultad de Informática at UPM has developed an envelope facade system, superinsulating (80-91% higher than current solutions), with cost savings in energy efficiency up to 77%, and highly transparent (89% in light transmission). Moreover, it allows free-form designs for use in all kind of architectural projects. The construction sector business sector is growing at a rate of 4,4-5,1% worldwide, in particular, the glazing manufacturing sector industry.

In pre-production development stage, this solution has already been highlighted by the MIT (Massachusetts Institute of Technology), through its main developer, Luis A. Alonso, as one of the young people under 35 years most innovative of the year in Spain (TR35, MIT Technology Review).

Technology solution supported by the Technical University of Madrid

Technology solution

F²TE³ is a new lightweight, slim, high energy efficient, envelope system that provides for seamless, free-form designs for use in architectural projects. Its innovative design combines thermal insulation materials (encapsulated transparent monolithic aerogel) with new technologies (vacuum chamber) to provide a vacuum insulation panel (VIP). The patented solution enables a complete facade system design, both in version transparent area for windows and opaque one for walls.

Model simulations ensure meet both spanish CTE (Technical Building Code) and UNE standards. F²TE³ technical performance provides highly relevant and specific values in terms of acoustics, energy performance and light transmission.

"Energy savings through the building envelope with a minimum thickness (3,5 cm transparent facade that insulates the same as a 30 cm conventional brick wall) including free-form designs"

Areas of application

- **Construction and materials:** energy efficiency applied to construction.

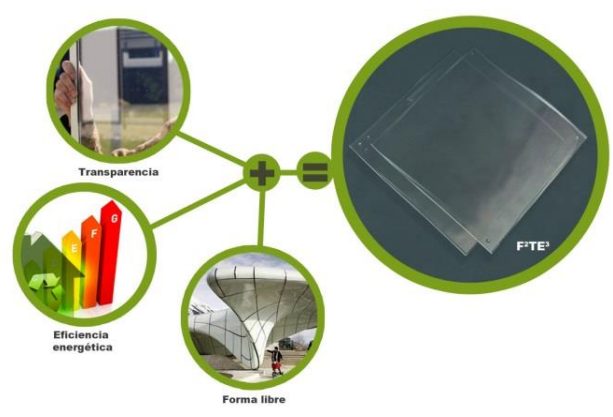

Market demands

- Energy inefficiency of building envelope solutions, particularly, the transparent ones. The challenge of curtain walls is energy saving and solar control to implement 20-20-20 targets by 2020 (reduce by 20% the primary energy consumption in the EU).
- Current challenge of designing curtain wall facades in a more spectacular and visual way.
- Improving the level of occupant satisfaction in buildings (for reference only, 27% higher in users of environmentally certified buildings) [LEED].
- Adapting the living spaces to the current needs of users, both professionally and personally.
- Structures with higher flexibility are required, in particular in geographic areas of greatest seismic hazard.

“Luis Alonso Pastor, F²TE³ main developer, has been highlighted by the Massachusetts Institute of Technology (MIT) as one of the young people under 35 years most innovative of the year in Spain”

“Improving insulation, energy efficiency and lifetime (5 times higher) than competing solutions, F²TE³ has a lower cost, around 1,4 and 3,7 lower than those ones”

Market potential

- The energy efficiency sector accounted for 1,8% of Spanish GPD in 2012. From 2005 to 2010, it drove 1.500 M€ just in partnership collaborations. [Ministerio de Economía y Competitividad, Gobierno de España].
- Worldwide, the construction industry worldwide is growing at a rate of 4.4-5.1%, in particular, the glazing area [Business Economics].
- The overall doors and windows market is a global business valued at 60.000 – 94.000 M€, and an approximately 5% growth, half of it focused on windows [Business Economics].
- Big companies in the curtain-wall industry account for 76% market, valued at 1.950 M€ at European level [Standard and Poor's].
- Spain is the second European manufacturer of windows, with an estimated 10% of production.

Competitive advantages

- 80-91% more insulation than current curtain-wall systems, which implies direct savings between 42-77% (according to the *British Fenestration Rating Council*).
- High degree of light transmission: 89% transparency.
- Maximized solar control: reducing UV transmission up to 0% and IR transmission up to 10%
- “Overlap” system between panels that is able to eliminate thermal bridging and to improve insulation in the union of those ones. This weakness has been detected in 90% of current commercial systems.
- Almost 100% recyclable.
- Soft covering: rigid and strict modules unrestricted.
- High strength: best existing rating according to UNE-EN 1419:2004 standard.

References

- Multidisciplinary promoter team of recognized standing in the fields of energy efficiency in buildings, manufacturing architectural panels and artificial intelligence and simulation.
- Solution already highlighted by the MIT, through its main developer, Luis A. Alonso, as one of the young people under 35 years most innovative of the year in Spain (TR35, MIT Technology Review).
- *Best Presentation Award* at 5th Global Institution Conference & Exhibition (Londres, 2010).

IPR

- Patent granted in Spain ES2398119 .
- International patent applied via PCT PCT/ES2013/070906 WO 2014/102424

Development stage

- Concept
- R & D
- Lab Prototype
- Industrial Prototype
- Production

F²TE³ contact (spin-off LAAP Technology)

Luis Alberto Alonso Pastor
ETS Arquitectura – UPM
e: luisalberto.alonso.pastorupm.es

UPM
spin-off

UPM contact

Innovation, Commercialization and
Entrepreneurship Area
Centre of Support for Technological Innovation –
UPM
e: innovacion.tecnologica@upm.es

INTELLIGLASS. The building as your energy source

Integrable transparent glazing facades to capture thermal energy and electricity through a water chamber and a photovoltaic layer

IntelliGlass glazings are products that can be used in the construction of glass buildings to reduce building energy demand and improve comfort. IntelliGlass technology is the result of 10 years of research by a team from the School of Aeronautical Engineering, Polytechnic University of Madrid (UPM). Currently, there is a 150 m2 curtain wall facing west at the University of Castilla La Mancha (Cuenca) where the advantage over conventional glazing lies in capturing thermal energy for the building's HVAC system. These glazing can also be used as interior partitions acting as cold or hot radiating surfaces. This is the case of a Multipurpose Building in Madarcos Endowment, Madrid..

Technology solution supported by the Technical University of Madrid

Technology solution

IntelliGlass is a technology that gives conventional glazing the ability to capture heat and electricity through a water chamber and a photovoltaic layer. The function of the water chamber is twofold: (i) on one hand, it prevents overheating glass building from infrared energy coming from the sun, and (ii) on the other hand, the energy is transported through a closed system of circulation water and a storage tank for comprehensive HVAC building. The role of the transparent photovoltaic film is to produce electricity for the consumption of the building or grid injection. So, this envelope solves three needs: the constructive one, the thermal energy associated to climatization and electricity associated to nocturnal lighting and/or electrical machines.

"The IntelliGlass glazing system transforms energy consumer buildings in producer buildings maintaining the aesthetics of glass"

Areas of application

- **Energy Sector:** energy consumption savings by means of both thermal and electrical production by glass buildings.
- **Environment Sector :** reducing emissions of greenhouse gases.

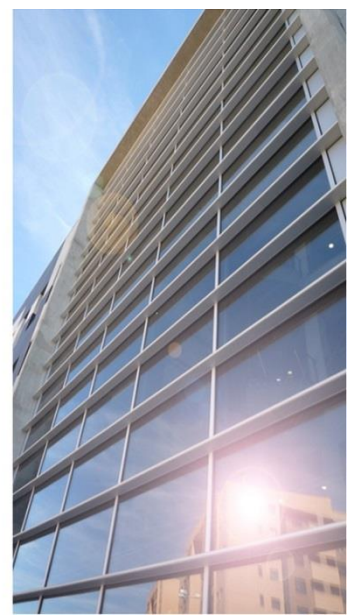
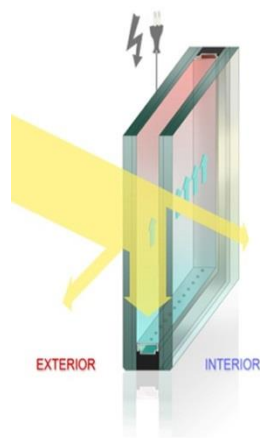

Market demands

Energy

- Public buildings and offices. There is a need to implement HVAC systems that reduce energy consumption and increase the comfort level inside buildings.
- Residential buildings. According to Eurostat, the price of electrical energy in Spain has increased by 60% in the last 10 years, so there is a clear need to reduce energy consumption in buildings maintaining the current trends in aesthetics.

Environment

- Need to reduce emissions of greenhouse gases.
- The building energy certification is now a necessity. To obtain certified LEED (Leadership in Energy & Environmental Design) seal is necessary for both the building's HVAC systems and the isolation of the building envelope.
- Horizon 2020. The European Commission has marked as milestones: (i) 20% reduction in energy consumption, (ii) production of 20% of the energy of a country through for Renewable Energy Sources and (iii) reduction of 20 % of emissions of greenhouse gases.

“The need to save energy in glazing buildings is essential with the shortage of energy resources and the rising cost of energy. The regenerative buildings are currently on demand”

Market potential

- The market for glass curtain walls has increased substantially in recent years, from \$ 12 billion in 2005 to \$ 25 billion in 2012 [Synovate Report].
- Considering the target countries, the United States accounts for 25% of the market with nearly \$ 6 billion, followed by China with \$ 6 billion and Europe with 5.7 billion. The remaining countries account for \$ 7 billion.
- According to the segmentation by type of building, office buildings represent a market of almost 16 billion dollars.
- Considering the segmentation by product, unitized curtain wall represents \$ 13 billion, followed by classical curtain walls rises to a volume of \$ 6 billion, and \$ 5 billion to other singular solutions for curtain walls.

Competitive advantages

- Thermal energy harvesting and production of electricity in the building envelope.
- Hot water for use both in cold facades of the building and HVAC systems.
- Increased thermal comfort inside the building associated to the removal of infrared radiation absorbed in the water chamber.
- Increased insulation of the envelope associated to the mass of the water chamber.
- Natural lighting associated to the transparency of the IntelliGlass glazing system.

References

- Universidad de Castilla La Mancha, Cuenca.
- Edificio Dotacional Polivalente, Madarcos.
- Edificio Residencial. Carcaixent, Valencia.
- Dpto. Matemática Aplicada Aeronáuticos, UPM.

IPR

- Patent granted in Spain ES2304871
- Patent granted in USA US8341894B2
- European patent via EPO EP2123856

Development stage

- Concept
- R & D
- Lab Prototype
- Industrial Prototype
- Production

IntelliGlass contact (spin-off Intelliglass)

Juan A. Hernández, Fernando del Ama,

Miguel Hermanns, César Hernández

e: info@intelliglass.es

w: www.intelliglass.com

UPM contact

Innovation, Commercialization and
Entrepreneurship Area

Centre of Support for Technological Innovation
– UPM

e: innovacion.tecnologica@upm.es

UPM
spin-off

HexBrick PLUS - New designs of ceramic bricks with hexagonal cells

Only one brick will be multiplied its sound absorption capacity on the equivalent of four bricks and half

A multidisciplinary team of UPM, of researchers from the School of Engineering and Industrial Design and School of Architecture, has developed new designs of ceramic bricks with horizontal hexagonal holes that improve the sound absorption characteristics of the conventional ceramic bricks with square or rectangular holes. This invention develops "new geometries" of cells of the ceramic bricks and constitutes a new, more efficient and a more competitive building system for wall construction. These new designs have won the award and the honorable mention for the best research paper in 2014 at the "International Conference on research related to Mechanical, Engineering Design & Advanced Manufacturing" held in Toulouse (France) in June 2014.

Technology solution supported by the Technical University of Madrid

Technology solution

HexBrick Plus is a new design of the internal geometry of ceramic bricks based on horizontal perforation with a hexagonal geometrical arrangement. It offers an innovative solution that satisfies the requirements of sound insulation of the walls keeping the exterior dimensions of the conventional bricks.

The improvements of the internal geometry of the horizontal hollow ceramic brick with cells hexagonal, under equal exterior dimensions, get multiply the sound absorption capacity of a single brick by the equivalent of four and half conventional bricks.

This new solution satisfies the requirements of sound insulation walls, without increasing the outside dimensions of conventional brick and also without increasing costs.

"The improvements made on the internal geometry of the horizontal hollow ceramic brick with hexagonal cells, under equal exterior dimensions, get multiply the sound absorption capacity of a single brick by the equivalent of four and half conventional bricks"

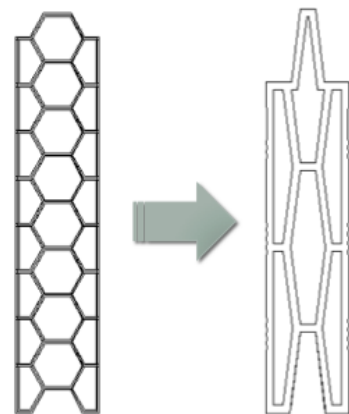

Areas of application

- **Construction:** construction of buildings.

Market demands

- Building systems that ensure acoustic comfort inside homes, without increasing costs.
- Technological solutions as well as improving the energy performance, comfort and sustainability, that are adaptable to customer needs, and are industrializable and competitive in price with traditional construction systems.
- The need to improve the mechanical resistance and the weight reduction has led bricks with lower acoustic absorption capacity, and therefore a higher transmission of noise.
- The current horizontal hollow ceramic brick has a square or rectangular hollow with a design that allows direct transmission of noise between the walls of said bricks. This arrangement makes the transmission of airborne noise between the outer faces of the wall it is direct and acoustic damping is very low.

"In the hollow ceramic bricks marketed with square or rectangular, their absorption capacity and noise damping are limited by the width dimension of the piece"

Market potential

▪ Global expectations

- The worldwide meteoric growth of construction (about 70%) is concentrated mainly in China, USA and India. [Oxford Economics y Global Construction Perspectives]
- Expecting an increase of around 33% in the USA employment for the period 2010-2020, reaching a total of 1.8 million jobs in the sector for 2020. [Statistical department, USA]

▪ Spain

- Growth of Spanish sector around 2,5% in 2015-2020 [Oxford Economics y Global Construction Perspectives]
- In Spain, the potential housing demand will be situated above 300,000.00 homes between 2011 and 2016. [BBVA, 2011]

Competitive advantages

- Under equal exterior dimensions, a single brick multiplies his sound absorption capacity by the equivalent of four and a half of conventional bricks"
- Properties of Large format LGF-LD, uncoated commercial bricks obtain an attenuation of 33 dBA (CTE DB-HR) and the LGF-LD "ladriyesos" ceramic bricks coated with plaster with a thickness between 5 and 10 mm are obtaining an attenuation over 50 dBA, inside Silensis System.
- If the manufacturers decide to use the new designs of ceramic bricks developed by our investigation, it would be necessary to revise upward the acoustic damping values indicated on this last point, No.9, both for uncoated and coated bricks, multiplied by more than FOUR times.

References

- These new designs have won the award and the honorable mention for best research paper in 2014 at the "International Conference on research related to Mechanical, Engineering Design & Advanced Manufacturing" held in Toulouse (France) in June 2014.
- Research Group with extensive research experience and collaboration with industry.

IPR

- Patent granted in Spain [ES2265234]
- Application for Patent of Addition in Spain [P201430877]

Development stage

- Concept
- R & D
- Lab Prototype
- Industrial Prototype
- Production

HexBrick PLUS contact

Pr. David Corbella Ribes
e: david.corbella@upm.es

UPM contact

Innovation, Commercialization and
Entrepreneurship Area
Centre of Support for Technological Innovation –
UPM
e: innovacion.tecnologica@upm.es

SisBA. Avoiding involuntary movements of tribachs

This locking system prevents tribach movements of topographic tripods of motorized measurement equipment.

Researchers from the Polytechnic University of Madrid (UPM) have developed a non-rotating lock system for a modified tribrach. The system developed prevents movement of the topographic locking device regarding its stand-by position, as it is much more firmly held than with previous systems. The system avoids the device's rotation with respect to tribrach, integrating and establishing a single reference system during the whole observation period.

Technology solution supported by the Technical University of Madrid

Technology solution

The anti-rotation blocking system proposed in the present invention comprises a locking element which fixes its tribrach adapter. It consists of the following parts:

- A cylindrical neck with plates that increase the set pressure without additional tools, such as screwdrivers or any other wrench.
- The main body with a truncated cone configuration that allows exerting greater pressure on the tribrach. This truncated cone shape allows greater fixation than a cylindrical shape.
- And a cylindrical threaded portion, which will allow attachment to the tribrach adapter.

This locking system is firstly introduced in the tribrach and subsequently in the tribrach adapter. The first hole is frusto-conically shaped and the second is screw-shaped to be screwed in.

Areas of application

- **Construction and infrastructure:** application to tribachs of scanner tripods of topographic or other purposes.

"This invention prevents rotation of the tribrach adapter and the device, integrating them"

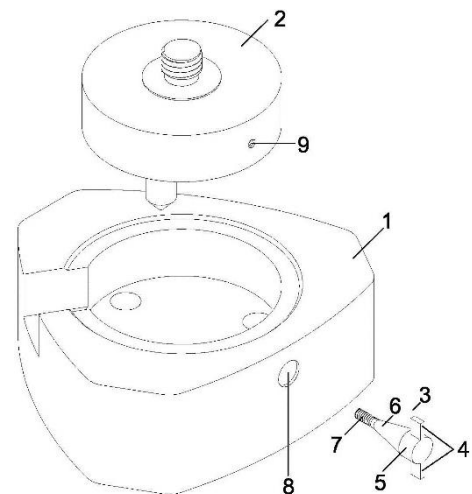

Market needs

- Measuring tools have evolved and many of them move independently, rotating around its rotation axis to perform measurements in all space directions.
- As with topographic devices such as tachometers, total stations, GPS receivers ..., terrestrial scanners rest on leveling platforms, the stability and immobility of which is extremely important in the measurement result.
- Although measuring tools have evolved, it has not been the same with fixation elements. These are not prepared to bear movements such as those scanners perform when measuring.



“Globally, the demand for infrastructure requires 57 trillion by 2030”

Market potential

Global expectations

- Meteoric growth in construction sector (around 70%) concentrated mainly in China, USA and India [Oxford Economics and Global Construction Perspectives].
- An employment increase by 33% is expected in the USA during the period 2010-2020, reaching a total of 1.8 million jobs in the sector in 2020 [Department of Statistics, USA].

Spain

- Expected growth of the sector in Spain by 2.5% in 2015-2020 [Oxford Economics and Global Construction Perspectives].
- Potential housing demand will be located above 300,000 households between 2011 and 2016 [BBVA Bank, 2011].

Competitive advantages

- There is no other technology on the market that solves the problem of bearing the movements made with measuring scanners.
- The locking system is easily enforceable.
- It is an easy to set-up device.
- The invention prevents the equipment movements as a result of measurement.
- It impedes a change in the measurement origin of horizontal angles, thus losing no instrument coordinate system.

References

- Extensive research activities and collaboration with industry.
- Research group oriented to technological innovation and implementation of patents.

IPR

- Utility Model granted in Spain [ES1087005U]

Development stage

- Concept
- R & D
- Lab Prototype
- Industrial Prototype
- Production

SisBA contact

Amparo Verdú Vázquez; Tomás Gil López; Fidel Carrasco Andrés
e: {amparo.verdu;tomas.gill; fidel.carrasco}@upm.es

UPM contact

Innovation, Commercialization and Entrepreneurship Area
Centre of Support for Technological Innovation – UPM
e: innovacion.tecnologica@upm.es



POLITÉCNICA

"Ingeniamos el futuro"

CAMPUS
DE EXCELENCIA
INTERNACIONAL

innovatech
UPM INNOVATIVE RESEARCH
UNIVERSIDAD POLITÉCNICA DE MADRID